



UNIVERSIDADE ESTADUAL DE CAMPINAS

FACULDADE DE ENGENHARIA QUÍMICA

**MODELAGEM E SIMULAÇÃO DO PROCESSO DE PRODUÇÃO DE PLA
(POLI-ÁCIDO LÁCTICO) OBTIDO A PARTIR DE FONTES RENOVÁVEIS
PARA USO BIOMÉDICO**

Autor: GUILLERMO ANDRÉS RUEDA MARTÍNEZ

Orientador: Prof. Dr. RUBENS MACIEL FILHO

Campinas - São Paulo
Agosto de 2011



UNICAMP

UNIVERSIDADE ESTADUAL DE CAMPINAS

FACULDADE DE ENGENHARIA QUÍMICA

ÁREA DE CONCENTRAÇÃO
DESENVOLVIMENTO DE PROCESSOS QUÍMICOS

GUILLERMO ANDRÉS RUEDA MARTÍNEZ

Modelagem e simulação do processo de produção de PLA (poli-ácido láctico) obtido a partir de fontes renováveis para uso biomédico

Orientador: Prof. Dr. RUBENS MACIEL FILHO

Dissertação de Mestrado apresentada à Faculdade de Engenharia Química como parte dos requisitos exigidos para a obtenção do título de Mestre em Engenharia Química.

Campinas - São Paulo
Agosto de 2011

FICHA CATALOGRÁFICA ELABORADA PELA
BIBLIOTECA DA ÁREA DE ENGENHARIA E ARQUITETURA - BAE - UNICAMP

R836m Rueda Martínez, Guillermo Andrés
Modelagem e simulação do processo de produção de
PLA (poli-ácido láctico) obtido a partir de fontes
renováveis para uso biomédico / Guillermo Andrés
Rueda Martínez. --Campinas, SP: [s.n.], 2011.

Orientador: Rubens Maciel Filho.
Dissertação de Mestrado - Universidade Estadual de
Campinas, Faculdade de Engenharia Química.

1. Biopolímeros. 2. Engenharia Tecidual. 3.
Simulação por computador. 4. Biocompatibilidade. 5.
Polimerização por abertura de anel. I. Maciel Filho,
Rubens. II. Universidade Estadual de Campinas.
Faculdade de Engenharia Química. III. Título.

Título em Inglês: Modeling and simulation of Poly(lactic acid) production
process obtained from renewable feedstocks for biomedical use

Palavras-chave em Inglês: Biopolymers, Tissue engineering, Computer
simulation, Biocompatibility, Ring opening
polymerization

Área de concentração: Desenvolvimento de processos químicos

Titulação: Mestre em Engenharia Química

Banca examinadora: Delba Nisi Cosme Melo, Otávio Cavalette

Data da defesa: 31-08-2011

Programa de Pós Graduação: Engenharia Química

Dissertação de Mestrado defendida por Guillermo Andrés Rueda Martínez e aprovada em 31 de Agosto de 2011 pela banca examinadora constituída pelos doutores:

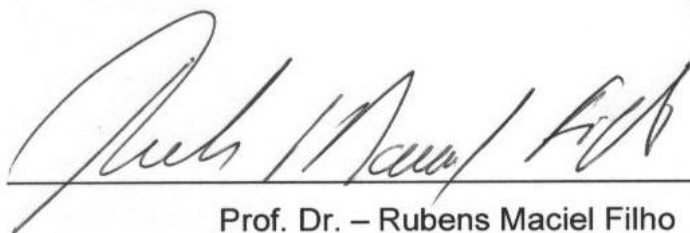

Prof. Dr. – Rubens Maciel Filho

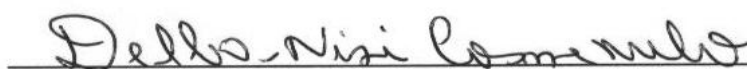

Dr^a. Delba Nisi Cosme Melo



Dr. Otávio Cavalette

Este exemplar corresponde à versão final da Dissertação de Mestrado em Engenharia Química.



Orientador: Prof. Dr. – Rubens Maciel Filho

Dedico como muito amor e carinho este trabalho principalmente a meu dois anjos e ídolos que estão no céu me iluminando e orando por mim em todo momento, meus pais, Martha Helena e Ivan Alberto; sempre foram, são e serão os meus exemplos de vida e estou muito orgulhoso de poder ser chamado teu filho. Também dedico este trabalho à minha família e amigos, porque são as outras pessoas importantes para mim, e todos meus sucessos são deles também. À minha “princesita”, Astrid Juliana, por ser parte da minha vida e estar do meu lado em cada momento. Este triunfo é o nosso, e este é apenas um de muitos mais que vamos conseguir juntos.

Agradecimentos

Primeiro gostaria de agradecer a Deus por me ajudar, iluminar e guiar sempre pelo caminho certo para terminar os meus objetivos propostos, por me permitir conhecer pessoas tão maravilhosas no longo da minha vida e por me dar oportunidades grandes e importantes.

Aos meus pais, Martha Helena e Ivan Alberto, pelas suas orações, pelo amor e pelos conselhos que foram, são e serão às bases da minha vida. Sem importar a distância e o tempo que já passou ainda as lembranças são bem fortes, ao igual que o desejo de virar uma pessoa com os mesmos valores.

Aos meus irmãos, Mauricio e Ricardo, pelo apoio e pela paciência, também pelos momentos que os três temos compartilhado e nos quais temos aprendido juntos, mesmo estando longe. Sem importar as brigas e os momentos difíceis sempre serão meus irmãozinhos.

A toda minha família, meus avôs, meus tios e primos, que me apoiaram nos momentos mais difíceis da minha vida, por me aconselhar e guiar para conseguir com sucesso minhas metas e responsabilidades.

À minha “princesa”, Astrid Juliana, pelo grande amor, por todos os momentos vividos, por todas as coisas compartilhadas, por me ter muita paciência e por ser uma base importante na minha vida. Espero sempre estar do seu lado e compartilhar muito mais tempo juntos.

Aos meus eternos amigos “irmãos”, Coche, Lucho, Piní, Ricardo, Diego, Osquitar e Uto, por todos os conselhos e pela grande e antiga amizade que é muito importante para mim e a qual espero continue por muitos anos mais.

Ao professor Rubens e à professora Maria Regina, pela amizade, a oportunidade de ser parte do LOPCA e do BIOFABRIS e pela confiança depositada na realização do meu mestrado e projetos de pesquisa.

Ao Jaiver, à Silvia e ao Jorge M., pela grande ajuda durante o desenvolvimento do meu projeto de mestrado, pela entrega sem compromisso, pelo carinho e pela amizade. São pessoas muito importantes para mim e espero sempre estar do seu lado e compartilhando muitos mais momentos.

À Marcele e ao Vinícius, pela grande amizade criada, pelos momentos de curtidão e de trabalho e pelo carinho de suas famílias na minha estância no Brasil. Também agradeço ao Tony, Ana Maria, Michelle, Ana Flávia, Anderson, Aulus e Marcio.

Ao André, à Ingrid, Paula e Roberta, pelo grande apoio, pelo conhecimento transmitido e pela amizade sincera. A sua orientação foi muito importante, mas os momentos compartilhados foram ainda mais. Obrigado por me ter acolhido como mais um da equipe e da salinha.

Aos meus amigos colombianos que até o final do percurso estiveram junto comigo, Ruben, Kari, Hencho, Lia, Jairo, Xnatis, Luchys, Olguita, Leo, Sergio, Oscar, Yerman e Yurany, também pelo carinho e pelo convívio durante o desenvolvimento da nossa vida no Brasil. Ao mesmo tempo, agradeço a todos os que participaram desta experiência e foram embora antes, Davinchis, Mauro, Oscar, Jairo, Moni, Julian, Laura, Ana M., Carlos M. e Sandra.

Aos meus amigos da graduação e da “Provincia”, Viviana, Nathaly, Dianis, Jorge, Morrales, Calita, Dulces, Juan Camilo, Oscar M., Mario, Bibian e Andrea.

Aos os colegas do LOPCA e do BIOFABRIS, pelo ambiente agradável de trabalho e amizade, especialmente ao Rodrigo, Mylene, Erika, Fernando, Edianara, Betânia, Edivaldo e Delba.

“Quando te dói olhar para atrás e te dá medo olhar adiante, mira para a esquerda ou a direita e ali estarão a teu lado. (amigos, família e Deus).”

Resumo

O desenvolvimento de materiais para a aplicação em engenharia tecidual vem sendo um dos grandes desafios na pesquisa de biomateriais. Polímeros não tóxicos e biocompatíveis ao corpo humano são estudados para viabilizar sua aplicação em técnicas avançadas de biofabricação, como a prototipagem rápida. Estas técnicas utilizam biomateriais, permitindo manipular e depositar nestes, células vivas em um processo de construção por camadas de matrizes ou “*scaffolds*”, possibilitando seu posterior uso como dispositivos médicos. Dentre os biomateriais que podem ser utilizados na prototipagem rápida para uso biomédico, encontra-se o poli (ácido láctico) ou PLA, o qual é sintetizado a partir do ácido láctico que pode ser obtido por fermentação de açúcares extraídos de fontes renováveis, tais como cana-de-açúcar e milho. O PLA é um polímero biocompatível usado em várias aplicações biomédicas, devido à sua degradabilidade em contato com fluidos corpóreos e capacidade de ser absorvido pelo corpo humano. Trata-se de um polímero muito versátil que pode ser produzido com ampla gama de propriedades. Devido a estas características, encontrar os valores ótimos de todas as variáveis para atingir propriedades específicas do produto, torna-se inviável experimentalmente, visto que há elevado custo e grande tempo requerido pelos experimentos. Neste contexto, o objetivo deste trabalho foi desenvolver uma planta de processamento virtual para estudar e simular o processo de síntese do PLA a partir de fontes renováveis usando o simulador comercial ASPEN PLUS[®]. Através das simulações foram identificadas as relações das propriedades do polímero com as condições operacionais (temperatura, pressão, entre outras) e de projeto (volume reacional), visando obter um produto final com alta massa molar e pureza.

Abstract

The development of successful materials for use in tissue engineering has been one of the major challenges in biomaterials research. Biocompatible polymers as well as advanced biomanufacturing techniques, such as rapid prototyping, have been extensively studied. These techniques use biomaterials that allow the manipulation and deposition of living cells in a layer-by-layer building process to create “scaffolds” for further use as medical devices. Poly (lactic acid) or PLA, which is synthesized from lactic acid obtained by fermentation of sugars derived from renewable sources such as sugar cane and corn, is one of the most common biomaterials employed in rapid prototyping. PLA is a biocompatible polymer used in several biomedical applications due to its high biodegradability in contact with body fluids and its ability to be absorbed by the human body. Furthermore, it is a very versatile polymer that can be produced with a wide range of properties. Therefore, the experimental process to adjust and optimize all the variables in order to achieve specific properties of the product is impractical, not only because of the high economic cost it involves, but also because of the time-consuming nature of the process. In this context, the study and simulation of the synthesis of PLA from renewable sources was proposed using the commercial simulator ASPEN PLUS® in order to identify the relationship between the polymer properties and the operating conditions (temperature, pressure, etc.) as well as the design conditions (reaction volume) so as to achieve a final product with high molecular weight number.

Sumário

Resumo	ix
Abstract	xvii
Sumário	xix
Listas de Figuras	xxiii
Listas de Tabelas	xxv
Nomenclatura	xxvii
Capítulo 1- Introdução	29
1.1 Objetivos	30
1.2 Organização da Dissertação	31
Capítulo 2- Área Biomédica.....	35
2.1 Introdução	35
2.2 Desenvolvimento.....	36
2.3 Conclusões	51
Capítulo 3- O poli (ácido láctico) (PLA)	53
3.1 Introdução	53
3.2 Desenvolvimento.....	54
3.3 Conclusões	70
Capítulo 4- Modelagem do Processo	71

4.1. Introdução	71
4.2. Desenvolvimento.....	71
4.2.1. <i>Dados cinéticos do processo de síntese do PLA</i>	71
4.2.2. <i>Balanços do processo de síntese do PLA em sistema em batelada</i>	78
4.2.3. <i>Balanços do processo de síntese do PLA em sistema contínuo</i>	86
4.3. Conclusões	94
Capítulo 5- Sistema Contínuo	95
5.1 Introdução	95
5.2 Desenvolvimento.....	95
5.3 Conclusões	102
Capítulo 6- Sistema em Batelada.....	103
6.1 Introdução	103
6.2 Desenvolvimento.....	103
6.3 Conclusões	110
Capítulo 7- Análises das Variáveis do Processo	111
7.1. Introdução	111
7.2 Desenvolvimento.....	111
7.3. Conclusões	145
Capítulo 8- Conclusões e Sugestões para Trabalhos Futuros	147
8.1 Conclusões	147

8.2	Sugestões Para Trabalhos Futuros.....	149
	Referências Bibliográficas	151
ANEXO A.	Perfis de Reatores CSTR.....	165

Listas de Figuras

Figura 1. Organização da dissertação.	33
Figura 2. Reator de oligomerização em batelada.	79
Figura 3. Reator de formação de lactídeo em batelada.	81
Figura 4. Reator de polimerização em batelada.	84
Figura 5. Reator CSTR de oligomerização.	87
Figura 6. Reator CSTR de formação de lactídeo.	89
Figura 7. Reator CSTR de polimerização.	91

Listas de Tabelas

Tabela 1. Componentes do sistema.....	72
Tabela 2. Segmentos dos componentes do sistema.....	74
Tabela 3. Espécies dos terminais dos componentes do sistema.....	75
Tabela 4. Reações geradas pelo software.....	76
Tabela 5. Reações inseridas pelo usuário.....	76
Tabela 6. Dados de velocidades de reação.....	77
Tabela 7. Dados de velocidades de reação para reações com lactídeo.....	78

Nomenclatura

ρ – Densidade

[Nucl] – Concentração do Componente Nucleofílico

[Elec] – Concentração do Catalisador Eletrofílico

[C_i] – Concentração do Catalisador

AL – Ácido Láctico

AL-D-END – Segmento Terminal D do Ácido Láctico

AL-L-END – Segmento Terminal L do Ácido Láctico

AL-R – Segmento Repetitivo do Ácido Láctico

C – Fluxo de Catalisador (*Catalyst*)

C₂ – Lactídeo

DPN – Número de Grau de Polimerização (*Degree Polymerization Number*)

E_a – Energia de Ativação

F – Fluxo Mássico

FC – Composição Mássica do Alimento (*Feed Composition*)

k – Constante de Velocidade

k₀ – Fator Pré-exponencial

MWN – Número de Massa Molar (*Molecular Weight Number*)

LAMF – Fluxo Mássico de Ácido Láctico (*Lactic Acid Mass Flow*)

LMF – Fluxo Mássico de Lactídeo (*Lactide Mass Flow*)

p – Fator de Significância

P – Pressão

PMF – Fluxo Mássico de PLA (*PLA Mass Flow*)

PL – Pureza de Lactídeo (*Purity Lactide*)

PLA – Poli (Ácido Láctico) (*Poly (Lactic Acid)*)

PP – Pureza de PLA (*Purity PLA*)

P_m – Polímero com *m* Moléculas de Monômero

P_{m+n} – Polímero com *m+n* Moléculas de Monômero

P_n – Polímero com *n* Moléculas de Monômero

P_{n+1} – Polímero com *n+1* Moléculas de Monômero

r – Velocidade de Reação

R – Constante Universal dos Gases

t – Tempo

T – Temperatura

T_{ref} – Temperatura de Referência

V – Volume

W – Água (*Water*)

WRC – Recuperação de Água na Coluna (*Water Recovery Column*)

x – Fração Mássica de Componentes

Capítulo 1- Introdução

Os avanços na medicina e engenharia moderna, juntamente com o incremento da expectativa de vida, têm incentivado o desenvolvimento de técnicas de biofabricação e biomateriais que auxiliam na melhora da qualidade de vida das pessoas (Jardini *et al.*, 2010). Estas técnicas devem permitir a imitação de estruturas vivas, tanto na forma e quanto na função, tornando-se possível a substituição de tecidos defeituosos ou faltantes (Wen *et al.*, 2002; Freed e Vunjak-Novakovic, 1998; Thomson *et al.*, 1995a). O desenvolvimento de materiais com as características requeridas para a aplicação na engenharia de tecido ósseo é um dos grandes desafios da pesquisa em biomateriais (Mikos e Temenoff, 2000). Entre estes materiais utilizados para biofabricação encontram-se os biopolímeros (Griffith, 2000). Estes polímeros podem entrar em contato com tecidos vivos, sem gerar nenhum tipo de risco, podendo ser sintéticos ou naturais (Chen *et al.*, 2004; Dai, *et al.*, 2010; Kulkarni *et al.*, 2010). Dentre os biomateriais, o poli (ácido láctico) ou PLA vem sendo amplamente utilizado no campo médico, devido a sua excelente biocompatibilidade e de seus copolímeros, recebendo, assim, grande atenção para pesquisa e produção (Chen *et al.*, 2002; Nair e Laurecin, 2007; Peter *et al.*, 1998; Temenoff e Mikos, 2000). O PLA é produzido a partir do ácido láctico e este pode ser obtido de fonte renováveis como a cana-de-açúcar (John *et al.*, 2007; Lunelli, 2010). Trata-se de um polímero termoplástico, com elevada resistência mecânica e capacidade de ser degradável no corpo humano por hidrólise simples do éster, a uma taxa que pode ser controlada (Gupta *et al.*, 2007; Auras *et al.*, 2004).

O processo de síntese do PLA pode ser desenvolvido de diversas formas. As mais conhecidas são: a policondensação direta do ácido láctico (monômero) e a abertura de anéis do dímero (lactídeo) (Auras *et al.*, 2010; Dutkiewicz *et al.*, 2003). Estas duas rotas de síntese do PLA se diferenciam em uma propriedade importante deste, o número de massa molar. A policondensação produz um polímero de baixa massa molar e a abertura de anéis utiliza este polímero de baixa massa molar (oligômero), para poder

sintetizar o lactídeo com auxílio de um catalisador. Os anéis do lactídeo produzido são quebrados na presença de um catalisador, onde, ao mesmo tempo, as cadeias vão se unindo, ocorrendo o processo de polimerização, resultando na formação de um produto de elevada massa molar (Gu *et al.*, 2008; Auras *et al.*, 2010). Como o número de variáveis envolvidas em cada uma das etapas do processo de abertura de anéis é elevado, requer-se um conhecimento do comportamento destas e um controle adequado (Cheng *et al.*, 2009, Auras *et al.*, 2004).

É difícil, demorado e custoso obter, experimentalmente, os melhores valores das variáveis existentes em um processo químico, visando atingir os requisitos ou propriedades desejadas de um produto. Neste caso, a simulação é uma ferramenta importante para determinar a influência destas variáveis no processo, as melhores condições operacionais para obter elevadas produtividades e prever as características finais do produto desejado. Portanto, as simulações podem fornecer uma visão de como se podem comportar os processos, identificando o impacto e o efeito das variáveis, que devem assim ser avaliadas experimentalmente. Também possibilita identificar as faixas e políticas operacionais, as quais o processo deve ser submetido para obter os resultados e produtos desejados. Nos simuladores comerciais como ASPEN PLUS[®], que possui a ferramenta Polymers Plus, pode-se simular vários tipos de polimerizações, fornecendo resultados compatíveis com a realidade. Isto é possível, devido ao banco de dados, modelos matemáticos e técnicas de solução que o simulador oferece, devendo ser adequadamente utilizadas para a construção da planta de processamento virtual.

1.1 Objetivos

O objetivo desta dissertação é desenvolver uma planta virtual para simular o processo de síntese do poli (ácido láctico) (PLA) obtido a partir do ácido láctico, derivado de processos fermentativos. Através das simulações é possível realizar estudos abrangentes do comportamento do processo, definir as políticas e faixas operacionais e identificar o impacto das variáveis operacionais no desempenho do

processo e nas características do produto obtido. Dentro deste contexto, os objetivos específicos são:

- Reunir informações sobre as aplicações na área biomédica do PLA, para entender as propriedades que devem ser analisadas neste trabalho;
- Reunir informações sobre as características do processo de polimerização do PLA por abertura de anéis;
- Simular o processo de uma planta de polimerização em sistema contínuo para obtenção do PLA, com dados cinéticos obtidos da literatura, utilizando ASPEN PLUS®;
- Simular o processo de obtenção do PLA em sistema de batelada e dimensões de bancada, com dados cinéticos obtidos da literatura, utilizando ASPEN PLUS®;
- Identificar e estudar o impacto das variáveis mais influentes no processo de polimerização do PLA, utilizando a técnica de planejamento de experimentos, visando altas conversões, recuperações e propriedades desejadas do polímero final como o número de massa molar (MWN).

1.2 Organização da Dissertação

O Capítulo 2 apresenta uma revisão da literatura sobre as principais aplicações no campo biomédico para o PLA, copolímeros e suas blends. Encontra-se ainda o uso da prototipagem rápida para uma futura fabricação de implantes biocompatíveis e absorvíveis para o corpo humano e as técnicas de fabricação convencionais destes.

Uma breve introdução sobre as características do PLA está presente no Capítulo 3, juntamente com as diferentes formas de obtenção (síntese) deste polímero. As propriedades do monômero e a química da reação também estão descritas neste capítulo, além da modelagem cinética do processo de síntese deste polímero pela via de abertura de anéis.

No Capítulo 4 descrevem-se os componentes do sistema de síntese de poli (ácido láctico), os segmentos destes utilizados, as reações geradas pelo ASPEN PLUS® (Polymer Plus) e as reações inseridas pelo usuário. Também são neste capítulo os dados cinéticos, para calcular as respectivas constantes cinéticas das reações. Além disso, este capítulo contém os balanços mássicos de cada componente para os dois sistemas de síntese de PLA: sistema com reatores contínuos e com reatores em batelada.

O Capítulo 5 apresenta a simulação do processo, contendo a síntese do PLA, a partir do ácido láctico, obtido de um processo fermentativo. Esta simulação tem como objetivo, reproduzir um processo de síntese de PLA industrial com reatores CSTR.

O Capítulo 6 contém a simulação do processo de obtenção de PLA utilizando três reatores em batelada, visando simular o processo de síntese de PLA desenvolvido no laboratório em escala de bancada.

No Capítulo 7 é realizada uma análise de sensibilidade paramétrica das variáveis importantes para cada etapa do processo de síntese do PLA no sistema de reatores em batelada, encontrando-se os modelos estatísticos que predizem o comportamento destas variáveis com a alteração de outras.

No Capítulo 8 são apresentadas as conclusões deste trabalho e sugestões para trabalhos futuros.

O fluxograma da Figura 1 ilustra de que forma a dissertação está organizada, com as inter-relações entre capítulos.



Figura 1. Organização da dissertação.

• *Guillermo Andrés Rueda Martínez* •

Capítulo 2- Área Biomédica

2.1 Introdução

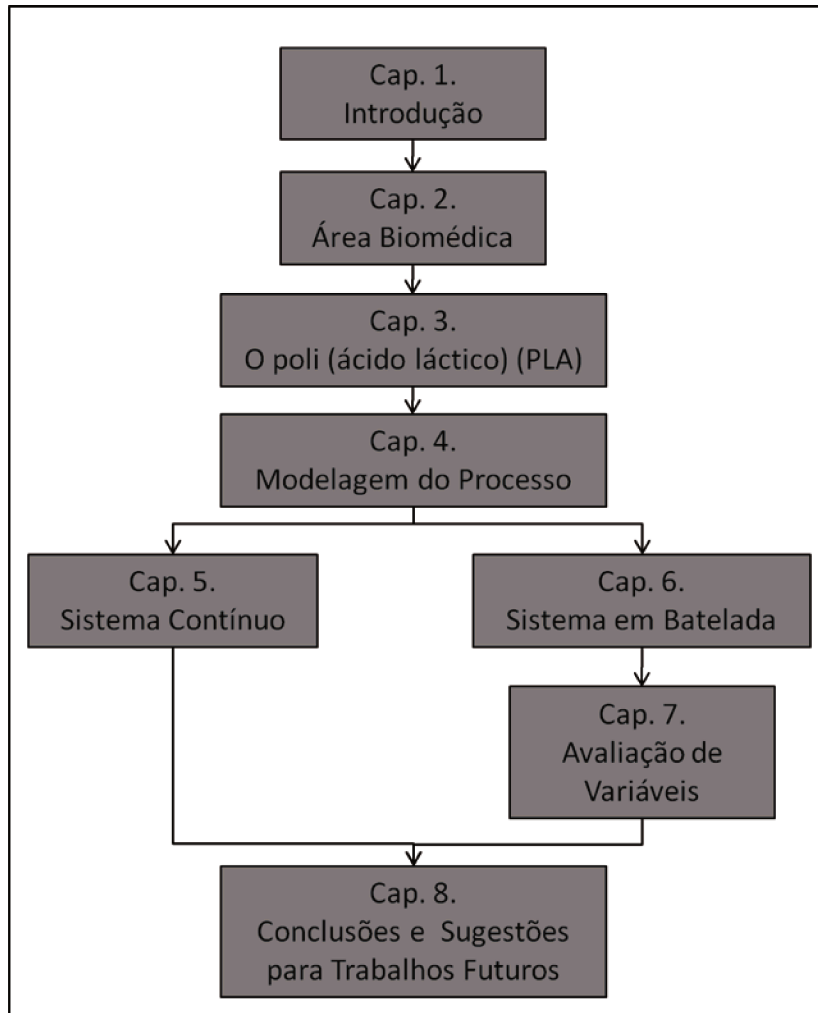
O desenvolvimento de novas técnicas de biofabricação e biomateriais tem auxiliado na melhoria da qualidade de vida das pessoas. Estas técnicas devem permitir a imitação de estruturas vivas, tanto na forma quanto na função, tornando-se possível a substituição de tecidos defeituosos ou faltantes (Atala e Lanza, 2002; Langer e Vacanti, 1993).

Atualmente, uma das técnicas mais importantes e estudadas para esta aplicação é o uso da tecnologia de prototipagem rápida industrial ou impressão 3D para a materialização de armações por deposição de biomateriais camada por camada, permitindo propagação de células vivas para estruturas teciduais (Yeong *et al.*, 2004; Bártolo *et al.*, 2004). Técnicas avançadas de prototipagem rápida se diferenciam de outras técnicas de biofabricação, porque permitem manipular e depositar células vivas em um processo de construção de matrizes por camadas, com controle de muitas variáveis e capacidade de produzir tecido de forma direta e órgãos completos, revolucionando este processo (Bacakova *et al.*, 2004; Atala e Lanza, 2002).

O uso de biomateriais como matéria prima na prototipagem rápida tem criado uma forma de fabricar diretamente implantes médicos (Hughes, 2006). Estes implantes, diferentemente dos convencionais, apresentam conformação anatômica excelente, têm projetos e formatos específicos para cada paciente, associado às microestruturas (na construção dos *scaffolds*) que contribuem no crescimento tecidual. Este tipo de materiais pode ser metálico, cerâmico ou polimérico, dependendo da aplicação (Hollister, 2005; Fang *et al.*, 2005, Sachlos e Czernuska, 2003).

Neste capítulo são abordados os avanços tecnológicos em biomateriais e técnicas de fabricação de *scaffolds* para aplicação em engenharia tecidual, estruturas e

composições destes materiais, bem como os métodos de fabricação tradicionais como: o vazamento de solvente, uso da espuma de gás e liofilização. Também serão apresentadas as ferramentas utilizadas para a modelagem e simulação do processo, tecnologia de prototipagem rápida para materializar estruturas e por último, as principais aplicações deste tipo de produto no campo biomédico.

2.2 Desenvolvimento

O desenvolvimento deste capítulo é apresentado a seguir, no artigo intitulado “*Computer-Aided Tools for Modeling and Simulation in the Biomaterials Production*”, publicado nos anais do VI *Latin American Congress of Artificial Organs and Biomaterials, 2010*.

COMPUTER-AIDED TOOLS FOR MODELING AND SIMULATION IN THE BIOMATERIALS PRODUCTION

André L. Jardini^{1,2}, Betânia H. Lunelli¹, Guillermo A. R. Martinez¹, Astrid J. R. Lasprilla¹, Marcelle F. Passos¹, Ana A. W. Maciel³, Jorge V. Silva⁴, Rubens Maciel Filho^{1,2}

¹Laboratory of Optimization, Design and Advanced Control,
School of Chemical Engineering, State University of Campinas, Campinas (SP), Brazil

²Institute of Biofabrication, Campinas (SP), Brazil

³School of Medicine Jundiaí, Jundiaí (SP), Brazil

⁴Information Technology Center, Campinas (SP), Brazil

E-mail: jardini@feq.unicamp.br

Abstract. *The advances in modern medicine, dentistry and engineering, combined with the increase life expectancy, have allowed the development of techniques for biomanufacturing and biomaterials that create a better life quality. These techniques should enable the mimicking of living structures, both in form and function, making it possible to replace defective or missing tissue. One of the techniques currently studied for this application is the use of industrial rapid prototyping technology (3D printing) to materialize structures layer by layer deposition on biomaterials, to allow colonization by living cells for tissue structure. Advanced techniques of rapid prototyping, able to manipulate and to deposit living cells in a process of building layers can to revolutionize the biomanufacturing, capable of producing direct tissue and even whole organs. The use of biomaterials as a raw material for rapid prototyping has created condition for direct making (without model) of implants (biomanufacturing). The implants, differently of the conventional, exhibit excellent anatomical conformity, having been designed specifically for the patient, associated with a microstructure (scaffolds) that contribute to the growth of tissues. This paper presents a review of the advances in biomaterials and scaffolds for application in the bone tissue engineering,, structure and composition of biomaterials, fabrication methods, tools for modeling and simulation of process, the rapid prototyping technology to materialize structures.*

Keywords: *Biomaterials, Modeling, Rapid prototyping, Scaffolds, Tissue engineering*

1. INTRODUCTION

The advances in modern medicine, dentistry and engineering, combined with the increase life expectancy, have allowed the development of techniques for biomanufacturing and biomaterials that create a better life quality. These techniques should enable the mimicking of living structures, both in form and function, making it possible to replace defective or missing tissue. Advanced techniques of rapid prototyping, able to manipulate and to deposit living cells in a process of building layers can to revolutionize the biomanufacturing, capable of producing direct tissue and even whole organs. The use of biomaterials as a raw material for rapid prototyping has created condition for direct making (without model) of implants (biomanufacturing). The implants, differently of the conventional, exhibit excellent anatomical conformity, having been designed specifically for the patient, associated with a microstructure (scaffolds) that contribute to the growth of tissues.

Tissue engineering is one of the most important areas of material science, in which multidisciplinary scientists are contributing to human health care, combining knowledge in medicine, biology and engineering integrated technology of cells, engineering materials, and suitable biochemical factors to create artificial organs and tissues, or to regenerate damaged tissues (Langer and Vacanti, 1993). The advent of tissue engineering has been motivated by the challenge of producing tissue substitutes that

can restore the structural features and physiological functions of natural tissues *in vivo* (Wen et al., 2002; Freed and Vunjak-Novakovic, 1998; Thomson et al., 1995a).

Beforetime, metallic and ceramic implants, synthetic biocompatible materials, and tissue grafts from human cadavers and other species have been the mainstream choices for restoration of lost tissues and organs (Rahaman and Mao, 2005).

Metals and ceramics have contributed to major advances in the medical field, particularly in orthopedic tissue replacement. However, metals and ceramics are not biodegradable and their processability is very limited. Conventional approaches of developing, identifying and applying “durable” materials for tissue/organ repair, such as stainless steel for total joint replacement and amalgam for tooth restoration, have been conceptually challenged by recent advances in developing of biocompatible, biodegradable and bioabsorbable polymers scaffolds that are capable of accommodating cell-drive tissue formation and undergo degradation while encapsulated cells synthesize tissue (Chen et al., 2002; Rahaman and Mao, 2005; Griffith, 2000). The interest in using the bioabsorbable polymer is mainly because they are degraded by hydrolysis; thereby preventing the patient undergoes a second surgery to remove the device, reducing cost and trauma. Its attributes make him a strong candidate in the biomedical and pharmaceutical industry, such as resorbable implant material and in the drug delivery systems.

The use of polymers in medicine dates back almost to the birth of the field of polymer science; virtually every early synthetic polymer found its way into experimental surgical studies soon after its invention and many endured to become staples of clinical practice (Griffith, 2000).

Synthetic polymers can stimulate isolated cells to regenerate tissues with defined sizes and shapes and are currently being studied as scaffolds for cell transplantation both in *in vitro* and *in vivo* (Freed et al., 1994a; Golden et al., 1990; Freed et al., 1993; Freed et al., 1994b; Langer and Vacanti, 1993; Cima et al., 1991; Mooney et al., 1994; Kim and Mooney, 1998; Lanzetta and Owen, 2005; Chen et al., 2006).

The present review focuses on the recent advances in the tissue engineering, biomaterials applications, techniques for scaffolds production, with the aim of demonstrate the integration of these advanced technologies for biomanufacturing and biomaterials that create a better life quality.

2. TISSUE ENGINEERING

Tissue engineering can be defined as the application of biological, chemical and engineering principles toward the repair, restoration or regeneration of living tissues using biomaterials, cells and factors, alone or in combination (Atala and Lanza, 2002; Langer and Vacanti, 1993). Over the past decades, the main goal of bone tissue engineering is to surpass the limitations of conventional treatments based on organ transplantation and biomaterial implantation (Yeong et al., 2004) using cells to regenerate the damage tissue, leaving only natural substances to restore organ function (Mikos and Temenoff, 2000; Griffith, 2000; Lalan et al., 2001). Current advances of engineering composite tissue constructs to repair multicell lineage tissue and organs represent a beginning rather than an end. The end goal of tissue engineering is to develop products capable of healing pathological or missing human tissues and organs (Rahaman and Mao, 2005). Tissue engineering is the most fascinating domain of medical technology where patients with organ defects and malfunctions are treated by using their own cells, grown on a polymer support so that a tissue part is regenerated from the natural cells (Gupta et al., 2007).

Tissue engineering involves the expansion of cells from a small biopsy, followed by the culturing of the cells in temporary three-dimensional scaffolds to form the new organ or tissue. Isolated and expanded cells adhere to the temporary scaffold in all three dimensions, proliferate, and secrete their own extracellular matrices, replacing the biodegrading scaffold (Chen et al., 2002). A critical challenge in tissue engineering is to regenerate tissues that grow and/or remodel in concert with the changing needs of the human body (Rahaman and Mao, 2005).

Tissue engineering presents enormous challenges and opportunities for materials science from the perspective of both materials design and materials processing (Griffith, 2000). Many artificial prosthetic devices are available to replace connective tissues such as joints, heart valves, blood vessels, and breasts,

few synthetic devices are able to perform adequately over the lifetime of the patient and devices vary greatly in their abilities to completely replace all the functions of the native tissue (Griffith, 2000).

Biodegradable scaffold play an important role in tissue engineering by supplying a three-dimensional (3D) substrate for cell expansion and tissue organization (Chen et al., 2002; Liu and Czernuszka, 2007; Nejati et al, 2009). Scaffold must provide sufficient mechanical strength and stiffness to substitute initially for wound contraction forces, and later for the remodeling of the tissue. The natural tissue regeneration processes then take place, blood vessels infiltrate the structure and the scaffold eventually degrades leading to newly formed tissue in place (Liu and Czernuszka, 2007).

2.1 Biomaterials

The term biomaterials has alternately been used to describe materials derived from biological sources or to describe materials used for therapies in the human body (Griffith, 2000). The development of biomaterials, bioabsorbable, and biodegradable materials with required characteristics for application in tissue engineering is one of the great challenges of research biomedical field.

Emerging applications in tissue engineering and drug delivery thus rely primarily on materials that resorb or degrade in body fluids so that the device ultimately disappears with no ill effects. Degradable polymers undergo extensive chain scission to form small soluble oligomers or monomers. Degradation may proceed by a biologically active process (e.g. enzymes present in body fluids participate) or by passive hydrolytic cleavage. Resorbable polymers gradually dissolve and are eliminated through the kidneys or other means. A wide variety of both solid and hydrogel-type polymers have been developed and many serve dual applications in drug delivery and tissue engineering (Griffith, 2000).

Bioabsorbable implants have been used extensively in medicine. Many have suggested interest in these materials for hand fractures since they may lead to less implant morbidity and subsequent stiffness, and they have additional advantages: they are radiolucent, they eliminate hardware removal procedures, they limit stress shielding, and they incrementally transfer load to healing fractures (Hughes, 2006).

Biomaterials used in tissue engineering scaffold fabrication can be divided into broad categories of synthetic or naturally derived, with a middle ground of semi-synthetic materials rapidly emerging (Griffith, 2002). Both natural and synthetic materials have been researched for use as tissue engineering scaffolds. The synthetic polymers can be easily mass-produced and their properties can be tailored for specific applications (Mikos and Temenoff, 2000).

With their excellent biocompatibility, important renewable feature, biodegradability, and other important properties poly-lactones such as poly (lactic acid) (PLA), poly-glycolic acid (PGA), and polycaprolactone (PCL), as well as their copolymers are becoming the most commonly used synthetic biodegradable polymers in the medical application (Cheng et al, 2009; Yang et al., 2001). These materials were first developed as materials for sutures and have been used clinically for over 20 years. They owe their broad use on their good biocompatibility and non-toxic degradation products (lactic acid and glycolic acid), which are produced by simple chemical hydrolysis (i.e., non-enzymatically; making their degradation rate highly consistent and predictable) and eliminated through normal metabolic pathways. The degradation rate and mechanical modulus of these polymers can easily be modulated by varying the lactide/ glycolide ratio and polymerization conditions (Coutu et al., 2009).

While biomaterials prepared from poly (lactic acid) are well tolerated by the body, producing minimal inflammation upon implantation, the lactic acid degradation product that is released and can dissociate to lactate may influence the metabolic function of cells in close proximity to the biomaterial. In addition to its role as an energy substrate for cells, lactic acid has been shown to have antioxidant properties that may serve to protect cells from damage due to free radicals that are naturally produced throughout a cell's life cycle (Lampe et al., 2009).

Lactic acid is a chiral molecule, existing in L and D isomers (the L isomer is the biological metabolite), and thus "poly (lactic acid)" actually refers to a family of polymers: pure poly-L-(lactic acid) (PLLA), pure poly-D-(lactic acid) (PDLA), and poly-D,L-(lactic acid) (PDLLA). Homopolymers of

PLLA and poly-caprolactone (PCL) are used clinically. The range of materials properties has been greatly extended, however, by co-polymerization of the various monomers (Griffith, 2000).

PLA is a highly versatile biodegradable polymer which can be tailor-made into different resin grades for processing into a wide spectrum of products. More importantly, the polymer can be processed using the conventional production infrastructure with minimal equipment modification (Lim et al., 2008).

The L-isomer constitutes the main fraction of PLA derived from renewable sources since the majority of lactic acid from biological sources exists in this form. Depending on the composition of the optically active L- and D, L-enantiomers, PLA can crystallize in three forms (α , β and γ) (Lim et al., 2008).

The PLLA, has distinguished by their excellent biocompatibility and mechanical properties were tested in several clinical studies. However, the long period required for its total degradation, coupled with the high crystallinity of its fragments can cause serious inflammatory reactions in the body of long duration, which restricts its use in some clinical applications. To reduce the crystallinity of PLLA can be used as a material combination of monomers L-lactic and D, L-lactic acid, and the latter is characterized by being rapidly degraded and do not generate crystalline fragments during this process (Baraúna, 2007).

Poly-caprolactone is a semi-crystalline, bioresorbable polymer belonging to the aliphatic polyester family. It is regarded as a soft and hard tissue-compatible bioresorbable material and has been used as scaffold for tissue engineering (Burkersroda et al., 2002). It has similar biocompatibility to PLA and PGA, but a much lower degradation rate (Park et al., 2006).

Other important synthetic biodegradable polymers include poly-ortho esters and poly-anhydrides (from non-physiological monomers), and they possess biocompatible, well-defined degradation characteristics. They are primarily designed for controlled drug delivery; however they have also been explored for use in tissue engineering (Muggli et al., 1999). Poly-propylene fumarate (PPF) is a linear polyester that contains multiple unsaturated double bonds that are available for covalent crosslinking of the polymer in the presence of freeradical initiators (Hedberg et al., 2005), and can degrade through hydrolysis of the ester bonds (Peter et al., 1998). An advantage of PPF over many other biodegradable synthetic polymers is that it can be utilized as an injectable system. Crosslinked PPF is biocompatible and osteoconductive, and its osteoinductive can be improved with calcium phosphates (Peter et al., 2000).

2.2 Scaffolds

The concept of an implant of key units (cells or proteins) inside a biodegradable porous material is known as a "scaffold" (Hollister, 2005). In theory, tissue scaffolds should be designed to have special characteristics in order to function as true tissue substitutes that satisfy the patient-specific biological, mechanical and geometrical requirements (Fang et al., 2005).

Tissue engineering holds great promise as a method of providing fully functional organs to counter the growing problem of donor organ shortage. Numerous approaches have been developed to form and process polymers for use in tissue engineering, and each distinct process possesses unique features and utility to form scaffolds for tissue engineering applications (Atala and Lanza, 2002).

Scaffolds provide the temporary structural framework for tissue-forming cells to synthesize extracellular matrices and other functional components in the intended shape and dimensions. Upon neogenesis of tissue or organs derived from stem cells, scaffolds undergo degradation (Rahaman and Mao, 2005).

Synthetic biomaterials (bioceramics and biopolymers) are the primary materials use for scaffold fabrication in various tissue engineering applications. The scaffold provides a framework and initial support for the cells to attach, proliferate and differentiate, and form an extracellular matrix which provides the structural integrity of tissue (Sachlos and Czernuska, 2003). The scaffold also serves as a carrier for cells, growth factors or other biomolecular signals. It is vital for the scaffold to mimic the structure and properties of human tissue to direct the macroscopic process of tissue formation (Chen et al., 2004; Liu and Czernuszka, 2007). Scaffolds must direct the arrangement of cells in an appropriate three-dimensional configuration and present molecular signals in appropriate spatial and temporal manner so

** Modelagem e simulação do processo de produção de PLA (poli-ácido láctico) obtido a partir de fontes renováveis para uso biomédico **

that the individual cells will form the desired tissue structures and do so in a way that can be carried out reproducibly, economically, and on a large scale (Griffith, 2000).

A successful scaffold should be designed to have special characteristics in order to function as true tissue substitutes that satisfy the patient-specific biological, mechanical and geometrical requirements (Gupta et al., 2007), and balance mechanical function with biofactor delivery, providing a sequential transition in which the regenerated tissue assumes function as the scaffolds degrades (Hollister, 2005). In bone tissue engineering, an ideal scaffold should have the following characteristics: (a) surface: suitable surface for cell attachment, proliferation, and differentiation; (b) architecture: three-dimensional and highly porous with an interconnected pore network for cell migration and transport of nutrients and metabolic waste; (c) mechanical property: a transitional structure with proper mechanical properties to allow the transfer of appropriate amount of biomechanical stress to the seeded cells; (d) degradation property: biocompatible and bioresorbable with a controllable degradation rate to match tissue growth, with degradation products being nontoxic and easily excretable (Leong et al., 2003; Chen et al, 2006; Liu and Czernuszka, 2007; Fang et al., 2005).

PLA, PGA and their co-polymer PLGA are well-known synthetic polymers, and have been extensively used as scaffolds biomaterials for cartilage tissue engineering and for various biomedical applications due to its favorable characteristics, as biocompatibility, biodegradability and mechanical property profile (Amass et al., 1999; Chen et al., 2002; Peter et al., 1998; Temenoff and Mikos, 2000). Example of scaffold used in the tissue engineering is shown in Fig. 1.

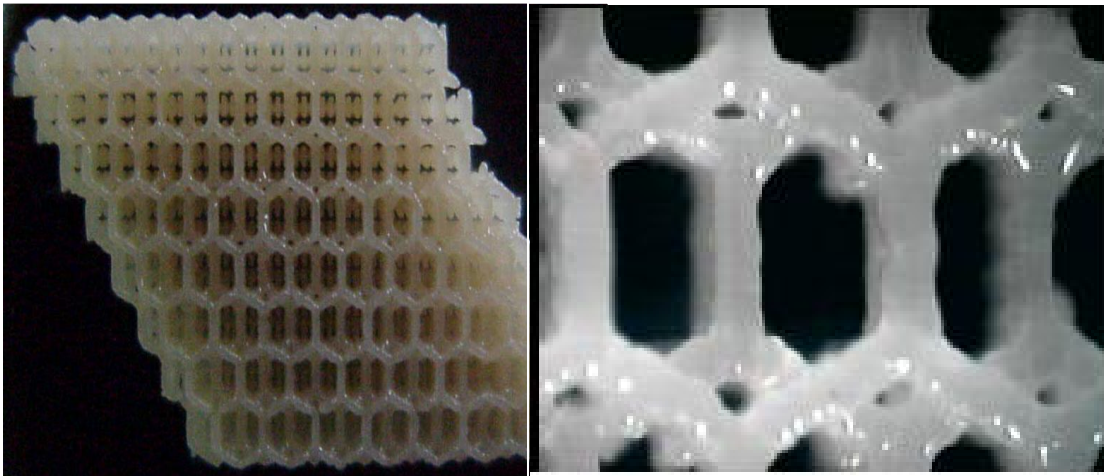

Figure 1. Image of scaffold used in the tissue engineering.

The scaffold attempts to mimic the function of the natural extracellular matrix. The primary roles of scaffold are: (a) to serve as an adhesion substrate for the cell, facilitating the localization and delivery of cells when they are implanted; (b) to provide temporary mechanical support to the newly grown tissue by defining and maintaining a 3D structure and (c) to guide the development of new tissues with the appropriate function (Kim and Mooney, 1998). The most common biopolymers used for scaffolds are indicated in Table 1.

Table 1. Biopolymers used for tissue scaffolds (Bártolo et al., 2004; Sachlos and Czernuszka, 2003)

<i>Polymer</i>	<i>Type</i>
<i>Synthetic</i>	Poly-glycolic acid
	Poly (lactic acid)
	Poly-ethylene glycol
<i>Natural</i>	Collagen
	Hyaluronic acid
	Alginate
	Agarose

Tissue engineering holds great promise as a method of providing fully functional organs to counter the growing problem of donor organ shortage. Numerous approaches have been developed to form and process polymers for use in tissue engineering, and each distinct process possesses unique features and utility to form scaffolds for tissue engineering applications (Atala and Lanza, 2002).

According with Yeong et al. (2004), many ways to produce scaffolds have been developed and these can be classified in two main groups: conventional techniques and advanced processing methods. However these have inherent limitations in these processing methods, which offer little capability precisely to control pore size, pore geometry, pore interconnectivity, spatial distribution of pores and construction of internal channels within the scaffold.

The conventional techniques to produce scaffolds includes solvent casting, particulate leaching, membrane lamination, emulsion freeze drying, polymer-ceramic, fiber meshes, fiber bonding , phase separation, melt molding, polymerization, gas foaming (Atala and Lanza, 2002; Freed et al., 1994a; Hsu et al., 1997; Lo et al., 1995; Mikos et al., 1994; Mooney et al., 1996; Thomson et al., 1995b; Whang et al., 1995). The technique used to manufacture scaffolds for tissue engineering is dependent on the properties of the polymer and its intended application (Thomson et al., 1997). It must allow the preparation of scaffolds with complex 3D geometries with controlled porosity and pore size, since these factors are associated with supplying of nutrients to transplanted and regenerated cells and thus are very important factors in tissue regeneration (Langer, 1999; Thomson et al., 1997). A brief review some of these conventional techniques to produce scaffolds will be considered in following. The information was obtained from Atala and Lanza (2002).

a) *Solvent casting*

It is a simple method for fabricating constructors, in which the polymer is dissolved in a suitable solvent and poured into a mold. The solvent is then removed, living the polymer set in the desired shape. This method is limited in the shapes that can be obtained. The principal advantage of solvent casting is the ease of fabrication without the need of especial equipment. Factors consider when choosing the solvent are the solvent's power, evaporation rate, solvent retention and toxicological properties.

b) *Membrane lamination*

Membrane lamination for encapsulated cell therapy is being investigated for the delivery of a wide range of products. The goal of encapsulated cell therapy research is to develop implants containing living xenogeneic or allogeneic cells to treat serious and disabling human conditions. The membranes can be fabricated for several methods, as phase inversion, thermal gelation phase inversion, diffusion-induced precipitation and post-treatments of dense films. Membrane strength and transport properties will be critical to any implantation systems.

c) *Freeze-drying*

* *Modelagem e simulação do processo de produção de PLA (poli-ácido láctico) obtido a partir de fontes renováveis para uso biomédico* *

This processing method consists of creating an emulsion by homogenization of a polymer solvent solution and water, rapidly cooling the emulsion to lock in the liquid state structure, and removing the solvent and water by freeze-drying. This involves fabricating scaffolds with high porosity, greater than 90%, the ability to control pore sizes ranging between 20 and 200 μm and the possibility to incorporation of protein-based growth.

d) *Polymer-ceramic*

To combine the osteoconductivity of calcium phosphates and good processability of polyesters, polymer/ceramic composite scaffolds have been developed for bone tissue engineering (Nejati et al, 2009). There are several different ceramics that have been used alone or in conjunction with polymers for orthopedic applications including tricalcium phosphate, tetracalcium phosphate, hydroxyapatite, and composites based on bioactive material. Ceramics have been combined with several degradable and non-degradable polymers to improve the polymer's strength, attachment to bone, porosity, and ability to encourage bony ingrowth. Of particular interest is the combination of PLAGA with hydroxyapatite into one multifunctional composite form, applicable in tissue engineering.

e) *Phase separation*

The controlled phase separation process has been used for years in the preparation of porous polymer membranes. Phase separation of the polymer solution can be induced in several ways, including non-solvent induced phase separation, chemically induced phase separation, and thermally induced phase separation. The pore morphology of the porous membrane varies depending on the polymer, solvent, concentration of the polymer solution, and the phase separation temperature.

f) *Polymerization*

Scaffolds formed as a consequence of polymerization have been used for tissue engineering and offer advantages over other scaffolding techniques because of the simplicity of the process. Poly-ethylene glycol-multi-acrylate and poly-2-hydroxyethyl methacrilate (PHEMA) can be crosslinked or polymerized *in situ*. PHEMA sponges have demonstrated cell invasion *in vivo* and *in vitro*, as is mandatory for tissue engineering applications.

g) *Gas foam*

Gas foam processing of polymers into tissue engineering matrices has unique advantages, including the ability to form scaffolds containing bioactive factors. Eliminating the requirement of organic solvents and high temperatures for fabrication enables the delivery of large, complex molecules such as growth factors, enzymes, and plasmid DNA to promote inductive tissue engineering applications.

There are inherent limitations in these processing methods, which offer little capability precisely to control pore size, pore geometry, pore interconnectivity, spatial distribution of pores and construction of internal channels within the scaffolds (Yeong et al., 2004), and these techniques involve the use of toxic organic solvents, long fabrication times and labour intensive processes (Lam et al., 2002).

The control over scaffold architecture using conventional techniques is highly process dependent rather than design dependent. Approach in a scaffold design must be able to create hierarchical porous structures to attain desired mechanical function and mass transport properties, and to produce these structures within arbitrary and complex three-dimensional anatomical shapes (Hollister, 2005). Determining how or even if designer scaffolds can improve tissue engineering treatment requires that these scaffolds can be first fabricated and then tested for mechanical function and tissue regeneration (Hollister, 2005). To allow greater control over scaffold architecture than isotropic methods, sophisticated techniques have been recently developed (Yang et al., 2002; Hollister, 2005). These techniques use computer assisted design to create customized 3D structures with well-defined internal architecture. The rapid prototyping (RP) is seen to be a viable alternative for achieving extensive and detailed control over scaffold architecture, and can be coupled to imaging data to approximate the anatomical defect to be repaired.

2.3. Rapid prototyping (RP)

Rapid Prototyping represents a new group of non-conventional fabrication techniques recently introduced in the medical field. The main advantages are both the capacity to rapidly produce very complex 3D models and the ability to use several raw of biomaterials (Bártolo et al., 2004).

RP is a common name for a group of techniques that can generate a physical model directly from computer-aided design data. Using the rapid prototyping technologies, the objects are manufactured by adding the material in successive layers. This step implies choosing the right RP technology according to the purpose of model itself as well as demanding accuracy, surface finish, and visual appearance of internal structures, number of desired colors in the model, strength, material, and mechanical properties. Finally 3D virtual model in STL format should be inputted into the RP commercial software for production of 3D physical model (Maciel Filho et al., 2009). Figure 2 provide a general overview of the necessary steps to produce rapid prototyping scaffolds for tissue engineering.

Rapid prototyping techniques are very specialized technologies in terms of material processability. Its medical models have found application for planning treatment for complex surgery procedures, training, surgical simulation, diagnosis, design and manufacturing of implants as well as medical tools (Maciel Filho et al., 2009).

Fabrication method offers the flexibility and capability to couple the design and development of a bioactive scaffold with the advances of cell-seeding technologies, to enhance the success of scaffold-based tissue engineering (Yeong et al., 2004). The scaffold should be remodeled and resorbed by growing cells and gradually replaced by the newly formed extracellular matrix and differentiated cells. A desirable feature would be synchronization of the polymer degradation rate with the rate of tissue in growth. Therefore, the degradation properties of a scaffold are of crucial importance for the success of the scaffold-based approach (Yeong et al., 2004). The interaction of cells with the scaffold is governed by both structural and chemical signaling molecules that have a decisive role for cell adhesion and the further behavior of cells after initial contact (Bacakova et al., 2004; Yeong et al.; 2004).

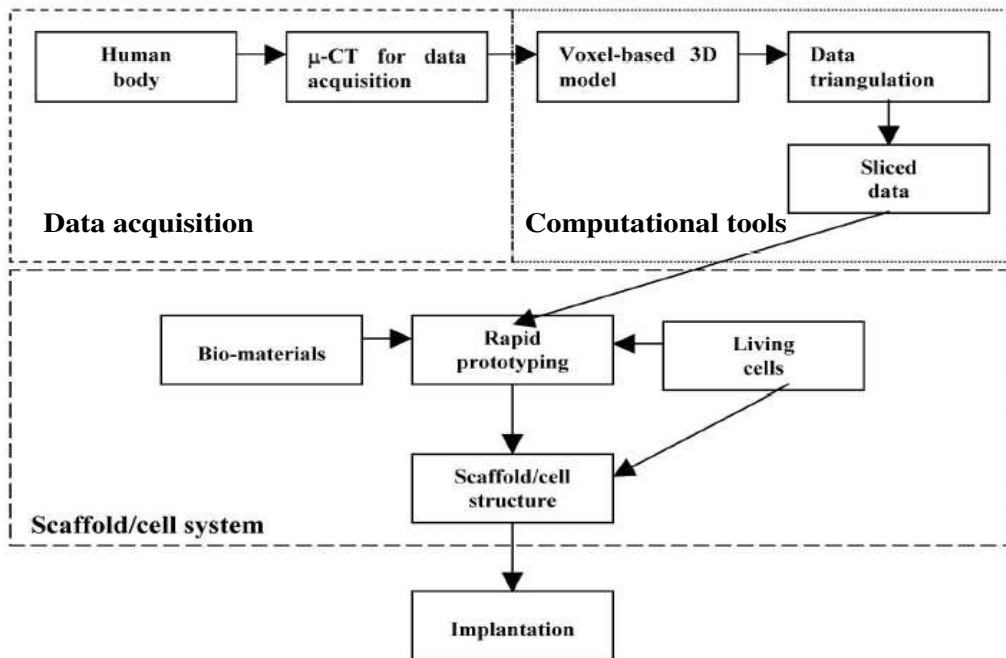

Figure 2. Steps for rapid prototyping scaffolds (Bártolo et al., 2004)

** Modelagem e simulação do processo de produção de PLA (poli-ácido láctico) obtido a partir de fontes renováveis para uso biomédico **

The most important rapid prototyping processes are photo-polymerization processes, laser sintering processes, sheet lamination processes, extrusion processes, ink-jet printing (Cheah et al., 2003; Yang et al, 2002; Bártolo et al., 2004; Leong et al., 2003; Landers et al., 2002). The main advantages and limitations of rapid prototyping scaffolds for tissue engineering are listed in Table 2.

Table 2. Advantages and limitations of the rapid prototyping (Cheah et al., 2003; Yang et al, 2002; Bártolo et al., 2004; Leong et al., 2003; Landers et al., 2002)

<i>Rapid Prototyping</i>	<i>Advantages</i>	<i>Limitations</i>
Photo-polymerization processes	Relative easy to achieve small feature	Limited by the development of photo-polymerisable, biodegradable and biocompatible materials; low geometrical complexity; limited to reactive and mostly toxic resins
Laser sintering processes	Relative higher scaffold strength; solvent free	Materials trapped in small inner holes is difficult to be removed; high temperatures in the chamber
Sheet lamination processes	Solvent free	Materials trapped in small inner holes is impossible to be removed
Extrusion processes	No materials trapped in the scaffold; solvent free	High heat effect on raw material: low geometrical complexity
Ink-jet printing	Low heat effect on raw powder; easy process; low cost	Materials trapped in small inner holes; lack of mechanical properties

The virtual model of internal structures of human's body, which is needed for final production of 3D physical model, requests very good segmentation with a good resolution and small dimensions of pixels. This demands good knowledge in this field which should help engineers to exclude all structures which are not the subject of interest in the scanned image and choose the right region of interest (separate bone from tissue, include just part of a bone, exclude anomalous structures, noise or other problems which can be faced). Depending on complexity of the problem this step usually demands collaboration of engineers with radiologists and surgeons who will help to achieve good segmentation, resolution and a finally accurate 3D virtual model (Milovanović and Trajanović, 2007). Figure 3 shows the solution that the 3D bioplotter offers for computer aided tissue engineering.

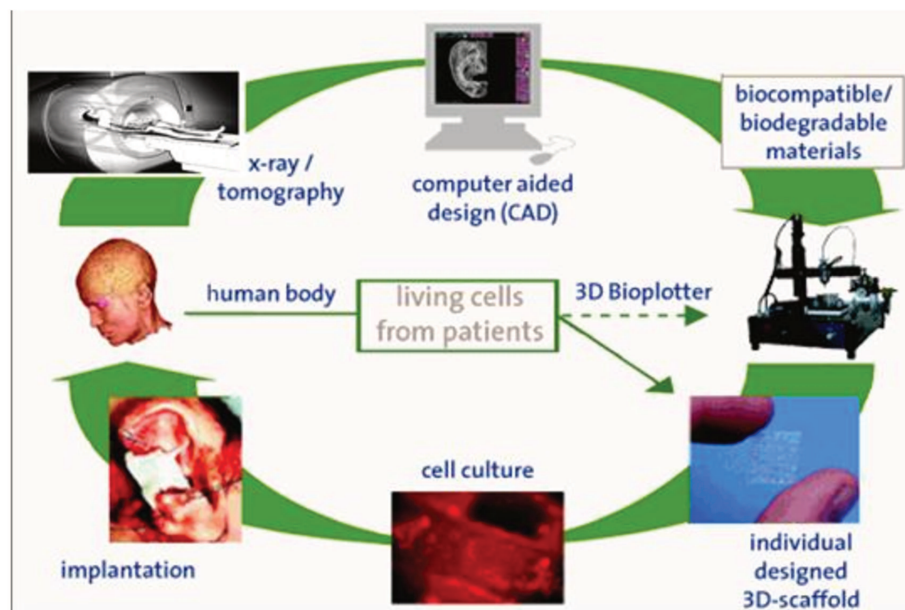

Figure 3. Bioplotter - solution for computer aided tissue engineering (EnvisionTec, 2010).

3. APPLICATIONS

Tissue engineering offers a promising new approach to restore and reconstruct the function of impaired tissues. The scaffolds advances provide well-defined porous structure and have proved to be excellent support matrixes for the seeding of large variety of cells. One of the most important interests in tissue engineering has been the development of 3D biodegradable scaffolds that guide cells to form functional tissue. For example, PLLA rods with stem muscle cells were used as scaffolds for bone formation in muscle by free tibial periosteal grafts (Gupta et al., 2007; Chen et al., 2006). Alternatively, when tissue specific expression is required, scaffolds can be used to facilitate delivery and engraftment of cells into a specific anatomic location for the treatment of cardiovascular, neurological, and orthopedic conditions for instance (Coutu, et al., 2009).

Several research efforts have produced hepatic assist devices utilizing living hepatocytes. Another research involves using islet cells to produce and regulate insulin, particularly in cases of diabetes. Liver protein deficiencies such as the hemophilias and metabolic liver diseases are a major class of monogenic diseases that could benefit from 3D scaffolds. Ectopically implanted gene-engineered cells seeded onto a 3D porous scaffold can provide long-term systemic protein delivery in a safe and potentially reversible manner. These scaffolds have not yet been thoroughly tested in vivo, but the relatively simple tissue architecture and good regenerative properties of the liver should facilitate the development of bioartificial livers for partial liver replacement or ectopic implantation (Coutu, et al., 2009).

A wide variety of materials are being developed for tissue engineering applications that involve the delivery of cells (Lampe et al., 2009). The field of cell and gene therapy for neurological disorders is still very young but already shows great promises. Yang et al., 2004 attempted to develop a porous polymeric nano-fibrous scaffold from PLLA for in vitro culture of nerve stem cells. The main challenge remains the identification of an appropriate cell source that could be used clinically. These cells coupled to an appropriate scaffold could direct neural progenitor cells differentiation and fate toward an appropriate phenotype leading to regeneration of the injured tissue (Coutu, et al., 2009).

Bone graft is often required to repair lesions caused by cancer, trauma (non-union fractures), for spine fusion, revision total joint arthroplasty, maxillofacial reconstruction, and segmental bone defect. Kellomäki et al., (2000) studied the design and manufacturing of different bioabsorbable scaffolds for guided bone regeneration and generation to be used as bone fixation devices.

The biology and fate of osteogenic stem cells (MSC) seeded on calcium phosphate ceramics has been thoroughly studied both in vitro and in vivo. MSC seeded on these materials and implanted in bone defects or subcutaneously can recapitulate both developmental processes of bone formation: endochondral ossification and intramembranous ossification (Behonick et al., 2007; Caplan, 2009). Three dimensional porous scaffolds seeded with MSC engineered to produce osteogenic proteins have also been tested in large animal models and showed promising results (Cancedda et al., 2007).

Three-dimensional porous scaffolds at the cell-based gene therapy for cardiovascular diseases have mainly been considered for myocardial regeneration after infarction or for peripheral arterial diseases. Myocardial muscle regeneration will occur depending on the cell type and scaffold material used. The scaffold should allow long-term survival, migration, and proliferation of cardiomyogenic cells, but also support functional (electrical, mechanical, tissular) integration with adjacent tissue and sustain the mechanical stress in the heart (Coutu, et al., 2009).

Bioartificial muscle tissues are also needed for the treatment of various myopathies caused by trauma or muscular dystrophies. Most preclinical and clinical trials have so far focused on myoblasts transplantation therapy, using skeletal muscle satellite cells (muscle stem cells) injected without scaffold materials (Scime et al., 2009). Furthermore, a number of different biomaterials have been shown to increase muscle progenitor cells engraftment in skeletal muscle. These include matrigel, collagen gels, fibrin gels, PLA, and PGA (Coutu, et al., 2009).

Regeneration of bone and cartilage defects can be accelerated by localized delivery of appropriate growth factors incorporated within biodegradable carriers. Synthetic polymers are the most widely used materials as growth factor delivery carriers in tissue engineering. Culture using scaffolds have been

created to obtain large amounts of chondrocytes with a well-maintained phenotype for cartilage tissue engineering (Lee and Shin, 2007). An exciting application, for which biodegradable polymers offer tremendous potential, is drug delivery. Alexis (2005) reviewed the factors that affect the degradation and drug-release rate of bio-erodible polymers for better control in biomedical applications. The use of 3D porous scaffolds to deliver cells and genes has already shown promises for a wide variety of applications but the intelligent design of the scaffolds to address specific requirements of cells or tissues is still in its infancy.

Nutrient limitation to cells is a major hurdle to overcome in building 3D scaffolds. Papenburg et al. (2009), they developed scaffolds of stacked multi-layered porous sheets featuring micro-channels fabricated by phase separation micromolding using poly-L(lactic acid) (PLLA). These porous micropatterned scaffolds can be used for multi-layer tissues (e.g. blood vessels) for culturing different cell types on various layers.

4. CONCLUSION

The growing number of publications has shown the great interest in developing highly porous biodegradable and bioabsorbable scaffolds suitable for use in tissue engineering. Tissue engineering is the most fascinating domain of medical technology where patients with organ defects and malfunctions are treated by using their own cells, grown on a polymer support so that a tissue part is regenerated from the natural cells. Numerous approaches have been developed to form and process polymers for use in tissue engineering, and each distinct process possesses unique features and utility to form scaffolds for tissue engineering applications. PLA is a biodegradable and bioabsorbable biopolymer used in a great variety of medical applications such as tissue engineering, drug delivery, biomedical devices, owing to its excellent biocompatibility and mechanical property. Among the different techniques for production of tissue scaffold the rapid prototyping represent a new group of non-conventional fabrication techniques with great capacity to produce scaffold with customized external shape and predefined internal morphology, and the ability to use several raw of biomaterials.

ACKNOWLEDGEMENTS

The authors wish to acknowledge the financial support provide by FAPESP (The Scientific Research Foundation for the State of São Paulo), CNPq (National Council for Scientific and Technological Development) and INCT-BIOFABRIS (National Institute of Science and Technology in Biofabrication).

REFERENCES

- Alexis, F. (2005), "Factors affecting the degradation and drug-release mechanism of poly(lactic acid) and poly-[(lactic acid)-co-(glycolic acid)], *Polymer International*, 54(1), 36-46.
- Amass, W., Amass, A. and Tighe, B. (1999), "A review of biodegradable polymers: uses, current developments in the synthesis and characterization of biodegradable polyester, blends of biodegradable polymers and recent advances in biodegradation studies", *Polymer International*, 47(2), 89-144.
- Atala, A. and Lanza, R. P. (2002), "Methods of tissue engineering", Elsevier, USA.
- Bacakova, L., Filova, E., Rypacek, F., Svorcik, V. and Stary, V. (2004), "Cell adhesion on artificial materials for tissue engineering", *Physiological Research*, 53, 35-45.
- Baráúna, G. S. (2007), "Obtention and characterization of PLDLA membranes for application as peripheral nervous regeneration prosthesis", *Thesis*, School of Chemical Engineering/UNICAMP, Campinas, SP.

- Bártolo, P., Mendes, A. and Jardini, A. L. (2004), "Bio-prototyping", *Design & Nature II*, M.W. Collins & C.A. Brebbia (Editors), WIT Press.
- Behonick, D. J., Xing, Z., Lieu, S., Buckley, J. M., Lotz, J. C. et al. (2007), "Role of matrix metalloproteinase 13 in both endochondral and intramembranous ossification during skeletal regeneration", *PLoS ONE*, 2(11), 1-10.
- Burkersroda, F. V., Schedl, L. and Gopferich, A. (2002), "Why degradable polymers undergo surface erosion or bulk erosion", *Biomaterials*, 23(21), 4221-4231.
- Cancedda, R., Giannoni, P. and Mastrogiacomo, M. (2007), "A tissue engineering approach to bone repair in large animal models and in clinical practice", *Biomaterials*, 28(29), 4240-4250.
- Caplan, A. I. (2009), "New era of cell-based orthopedic therapies", *Tissue Engineering Part B: Review*, 15(2), 195-200.
- Chen, G., Ushida, T. and Tateishi, T. (2002), "Scaffold design for tissue engineering", *Macromolecular Bioscience*, 2, 67-77.
- Chen, G., Zhou, P., Mei, N., Chen, X., Shao, Z., Pan, L. and Wu, C. (2004), "Silk fibroin modified porous poly(ϵ -caprolactone) scaffold for human fibroblast culture in vitro", *Journal of Materials Science: Materials in Medicine*, 15(6), 671-677.
- Chen, Y., Mak, A. F. T., Wang, M., Li, J. and Wong, M. S. (2006), "PLLA scaffolds with biomimetic apatite coating and biomimetic apatite/collagen composite coating to enhance osteoblast-like cells attachment and activity", *Surface and Coatings Technology*, 201, 575-580.
- Cheng, Y., Deng, S., Chen, P. and Ruan, R. (2009), "Polylactic acid (PLA) synthesis and modifications: a review", *Frontiers of Chemistry in China*, 4(3), 259-264.
- Cheah, C. M., Chua, C. K., Leong, K. F. and Chua, S. W. (2003), "Development of a tissue engineering scaffold structure library for rapid prototyping. Part 1: investigation and classification", *The International Journal of Advanced Manufacturing Technology*, 21(4), 291-301.
- Cima, L. G., Vacanti, J. P., Vacanti, C., Ingber, D., Mooney, D. and Langer, R. (1991), "Tissue engineering by cell transplantation using degradable polymer substrates", *Journal of Biomechanical Engineering*, 113(2), 143-151.
- Coutu, D. L., Yousefi, A. M. and Galipeau, J. (2009), "Three-dimensional porous scaffolds at the crossroads of tissue engineering and cell-based gene therapy", *Journal of Cellular Biochemistry*, 108(3), 537-546.
- EnvisionTec (2010), Available at: <http://www.envisiontec.de>. Accessed: April 2010.
- Fang, Z., Starly, B. and Sun, W. (2005), "Computer-aided characterization for effective mechanical properties of porous tissue scaffolds", *Computer-Aided Design*, 37(1), 65-72.
- Freed, L. E., Marquis, J. C., Nohria, A., Emmanuel, J., Mikos, A. G. and Langer, R. (1993), "Neocartilage formation in vitro and in vivo using cells cultured on synthetic biodegradable polymers", *Journal of Biomedical Materials Research*, 27(1), 11-23.
- Freed, L. E., Marquis, J. C., Langer, R., Vunjak-Novakovic, G. and Emmanuel, J. (1994a), "Composition of cell-polymer cartilage implants", *Biotechnology and Bioengineering*, 43(7), 605-614.
- Freed, L. E., Vunjak-Novakovic, G., Biron, R. J., Eagles, D. B., Lesnoy, D. C., Barlow, S. K. and Langer, R. (1994b), "Biodegradable polymer scaffolds for tissue engineering", *Nature Biotechnology*, 12, 689-693.
- Freed, L. E. and Vunjak-Novakovic, G. (1998), "Culture of organized cell communities", *Advanced Drug Delivery Reviews*, 33, 15-30.
- Golden, M. A., Hanson, S. R., Kirkman, T. R., Schneider, P. A. and Clowes, A. W. (1990), "Healing of polytetrafluoroethylene arterial grafts is influenced by graft porosity", *Journal of Vascular Surgery*, 11(6), 838-844.
- Griffith, L. G. (2000), "Polymeric biomaterials", *Acta Materials*, 48, 263-277.
- Gupta, B., Revagade, N. and Hilborn, J. (2007), "Poly(lactic acid) fiber: An overview", *Progress in Polymer Science*, 34(4), 455-482.

- Hedberg, E. L., Kroese-Deutman, H. C., Shih, C. K., Crowther, R. S., Carney, D. H., Mikos, A. G. and Jansen, J. A. (2005), "In vivo degradation of porous poly(propylene fumarate)/poly(DL-lactic-co-glycolic acid) composite scaffolds", *Biomaterials*, 26(22), 4616-4623.
- Hollister, S. J. (2005), "Porous scaffold design for tissue engineering", *Nature Materials*, 4, 518-524.
- Hsu, Y. Y., Gresser, J. D., Trantolo, D. J., Lyons, C. M., Gangadharam, P. R. and Wise, D. L. (1997), "Effect of polymer foam morphology and density on kinetics of in vitro controlled releases of isoiazid from compressed foam matrices", *Journal of Biomedical Materials Research*, v. 35(1), p. 107-116.
- Hughes, T. B. (2006), "Bioabsorbable implants in the treatment of hand fractures: an update", *Clinical Orthopaedics and Related Research*, 445, 169-174.
- Kellomäki, M., Niiranen, H., Puumanen, K., Ashammakhi, N., Waris, T. and Törmälä, P. (2000), "Bioabsorbable scaffolds for guided bone regeneration and generation", *Biomaterials*, 21(24), 2495-2505.
- Kim, B. S. and Mooney, D. J. (1998), "Development of biocompatible synthetic extracellular matrices for tissue engineering", *Trends in Biotechnology*, 16(5), 224-230.
- Lalan, S., Pomerantseva, I. and Vacanti, J. P. (2001), "Tissue engineering and its potential impact on surgery", *World Journal of Surgery*, 25(11), 1458-1466.
- Lam, C. X. F., Mo, X. M., Teoh, S. H. and Hutmacher, D. W. (2002), "Scaffold development using 3D printing with a starch-based polymer", *Materials Science and Engineering*, 20, 49-56.
- Lampe, K. J., Namba, R. M., Silverman, T. R., Bjugstad, K. B. and Mahoney, M. J. (2009), "Impact of lactic acid on cell proliferation and free radical induced cell death in monolayer cultures of neural precursor cells", *Biotechnology and Bioengineering*, 103(6), 1214-1223.
- Landers, R., Pfister, A., Hübner, U., John, H., Schmelzeisen, R. and Mülhaupt, R. (2002), "Fabrication of soft tissue engineering scaffolds by means of rapid prototyping techniques", *Journal of Materials Science*, 37(15), 3107-3116.
- Langer, R. (1999), "Selected advances in drug delivery and tissue engineering", *Journal Controlled Release*, 62, 7-11.
- Langer, R. and Vacanti, J. P. (1993), "Tissue engineering", *Science*, 260 (5110), 920-926.
- Lanzetta, M. and Owen, E. (2005), "Achieving better patency rates and neoendothelialization in 1-millimeter polytetrafluoroethylene grafts by varying fibril length and wall thickness", *Microsurgery*, 13(2), 76-83.
- Lee, S. H. and Shin, H. (2007), "Matrices and scaffolds for delivery of bioactive molecules in bone and cartilage tissue engineering", *Advanced Drug Delivery Reviews*, 59, 339-359.
- Leong, K. F., Cheah, C. M. and Chua, C. K. (2003), "Solid freeform fabrication of three-dimensional scaffolds for engineering replacement tissue and organs", *Biomaterials*, 24(13), 2363-2378.
- Lim, L. T., Auras, R. and Rubino, M. (2008), "Processing technologies for poly(lactic acid)", *Progress in Polymer Science*, 33, 820-852.
- Liu, C. Z. and Czernuszka, J. T. (2007), "Development of biodegradable scaffolds for tissue engineering: a perspective on emerging technology", *Materials Science and Technology*, 23(4), 379-391.
- Lo, H., Ponticiello, M. S. and Leong, K. W. (1995), "Fabrication of controlled release biodegradable foams by phase separation", *Tissue Engineering*, 1(1), 15-28.
- Maciel Filho, R., Bineli, A. R. R. and Jardim, A. L. (2009), "Bio-fabrication integrated computational tools", in: *10th International Symposium on Process Systems Engineering - PSE*.
- Mikos, A. G. and Temenoff, J. S. (2000), "Formation of highly porous biodegradable scaffolds for tissue engineering", *Electronic Journal of Biotechnology*, 3(2), 114-119.
- Mikos, A. G., Thorsen, A. J., Czerwonka, L. A., Bao, Y., Langer, R., Winslow, D. N. and Vacanti, J. P. (1994), "Preparation and characterization of poly(L-lactic acid) foams", *Polymer*, 35(5), 1068-1077.
- Milovanović, J. and Trajanović, M. (2007), "Medical applications of rapid prototyping", *Mechanical Engineering*, 5(1), 79-85.
- Mooney, D. J., Organ, G., Vacanti, J. P. and Langer, R. (1994), "Design and fabrication of biodegradable polymer devices to engineer tubular tissues", *Cell Transplantation*, 3(2), 203-210.

- Mooney, D. J., Baldwin, D. F., Suh, N. P., Vacanti, J. P. and Langer, R. (1996), "Novel approach to fabricate porous sponges of poly (D, L – lactic-co-glycolic acid) without the use of organic solvents", *Biomaterials*, 17(14), 1417-1422.
- Muggli, D. S., Burkoth, A. K. and Anseth, K. S. (1999), "Crosslinked polyanhydrides for use in orthopedic applications: degradation behavior and mechanics", *Journal of Biomedical Materials Research*, 46(2), 271-278.
- Nejati, E., Firouzdar, V., Eslaminejad, M. B. and Bagheri, F. (2009), "Needle-like nano hydroxyapatite/poly(L-lactide acid) composite scaffold for bone tissue engineering application", *Materials Science and Engineering:C*, 29(3), 942-949.
- Papenburg, B. J., Liu, J., Higuera, G. A., Barradas, A. M. C., Bôer, J., van Blitterswijk, C. A., Wessling, M. and Stamatialis, D. (2009), "Development and analysis of multi-layer scaffolds for tissue engineering", *Biomaterials*, 30(31), 6228-6239.
- Park, K. E., Kang, H. K., Lee, S. J., Min, B. M. and Park, W. H. (2006), "Biomimetic nanofibrous scaffolds: preparation and characterization of PGA/Chitin Blend Nanofibers", *Biomacromolecules*, 7(2), 635-643.
- Peter, S. J., Miller, M. J., Yasko, A. W., Yaszemski, M. J. and Mikos, A. G. (1998), "Polymers concepts in tissue engineering", *Journal of Biomedical Materials Research*, 43(4), 422-427.
- Peter, S. J., Lu, L., Kim, D. J. and Mikos, A.G. (2000), "Marrow stromal osteoblast function on a poly(propylene fumarate)/b-tricalcium phosphate biodegradable orthopaedic composite", *Biomaterials*, 21, 1207–1213.
- Rahaman, M. N. and Mao, J. J. (2005), "Stem cell-based composite tissue constructs for regenerative medicine", *Biotechnology and Bioengineering*, 91(3), 261-284.
- Sachlos, E. and Czernuszka, J. T. (2003), "Making tissue engineering scaffolds work. Review: the application of solid freeform fabrication technology to the production of tissue engineering scaffolds", *European Cells & Materials*, 5, 29-39.
- Scime, A., Caron, A. Z. and Grenier, G. (2009), "Advances in myogenic cell transplantation and skeletal muscle tissue engineering", *Frontiers in Bioscience*, 14, 3012–3023.
- Temenoff, J. S. and Mikos, A. G. (2000), "Review: tissue engineering for regeneration of articular cartilage", *Biomaterials*, 21(5), 431-440.
- Thomson, R. C., Wake, M. C., Yaszemski, M. J. and Mikos, A. G. (1995a), "Biodegradable polymer scaffolds to regenerate organs", *Advances in Polymer Science*, 122, 247-274.
- Thomson, R. C., Yaszemski, M. J., Powers, J. M., Mikos, A. G. (1995b), "Fabrication of biodegradable polymer scaffold to engineer trabecular bone", *Journal of Biomaterials Science*, 7(1), 23-38.
- Thomson, R., Yaszemski, M. and Mikos, A. (1997), "Polymer scaffold processing", in: Lanza R, Langer R, Chick W, editors. Principles of tissue engineering. New York: Academic Press, 263-272.
- Wen, C. E., Yamada, Y., Shimojima, K., Chino, Y., Asahina, T. and Mabuchi, M. (2002), "Processing and mechanical properties of autogenous titanium implant materials", *Materials in Medicine*, 13(4), 397-401.
- Wang, K., Thomas, C. H., Healy, K. E. and Nuber, G. (1995), "A novel method to fabricate bioabsorbable scaffolds", *Polymer*, 36(4), 837-842.
- Yang, S., Leong, K. F., Du, Z. and Chua, C. K. (2001), "The design of scaffolds for use in tissue engineering: Part I. Traditional factors", *Tissue Engineering*, 7(6), 679-689.
- Yang, S., Leong, K. F., Du, Z. and Chua, C. K. (2002), "The design of scaffolds for use in tissue engineering. Part II. Rapid prototyping techniques", *Tissue Engineering*, v. 8, p. 1–11.
- Yang, F., Murugan, R., Ramakrishna, S., Wang, X., Ma, Y. X. and Wang, S. (2004), "Fabrication of nano-structured porous PLLA scaffold intended for nerve tissue engineering", *Biomaterials*, 25(10), 1891–1900.
- Yeong, W. Y., Chua, C. K., Leong, K. F. and Chandrasekaran, M. (2004), "Rapid prototyping in tissue engineering: challenges and potential", *Trends in Biotechnology*, 22(12), 643-652.

2.3 Conclusões

O crescente número de publicações tem demonstrado um grande interesse no desenvolvimento de matrizes (*scaffolds*) feitas com materiais poliméricos, as quais são altamente porosas, são degradáveis em contato com fluidos corpóreos e absorvíveis, adequadas para uso em engenharia tecidual.

A engenharia tecidual é o campo mais fascinante da tecnologia médica, onde os pacientes com órgãos defeituosos e com mau funcionamento são tratados com o uso de suas próprias células, as quais podem ser cultivadas em um suporte polimérico, de modo que uma parte do tecido seja regenerada a partir de células naturais. Numerosos estudos têm sido desenvolvidos para formar e sintetizar polímeros, visando o uso em biofabricação, e cada um destes polímeros é distinto e possui características únicas, úteis na fabricação de matrizes ou *scaffolds* com potencial nas aplicações biomédicas.

O PLA é um material polimérico biodegradável e bioabsorvível, utilizado em uma grande variedade de aplicações médicas, tais como a engenharia tecidual, liberação controlada de medicamentos, dispositivos biomédicos, dentre outras. Isto ocorre devido à sua excelente biocompatibilidade, alta biodegradabilidade em contato com fluidos corpóreos, capacidade de absorção no corpo humano e propriedades mecânicas.

Entre as diferentes técnicas para a fabricação de armações ou matrizes de tecido (*scaffolds*), a prototipagem rápida representa um novo grupo de técnicas não convencionais de biofabricação, com grande capacidade para produzir *scaffolds* de forma externa personalizada, morfologia interna pré-definida e capacidade de utilizar matérias-primas diversas a partir de biomateriais como polímeros, metais e cerâmicas.

• *Guillermo Andrés Rueda Martínez* •

Capítulo 3- O poli (ácido láctico) (PLA)

3.1 Introdução

Os polímeros bioabsorvíveis são considerados uma excelente alternativa para o avanço e desenvolvimento de numerosas aplicações na medicina. O PLA é um dos biopolímeros mais promissores, devido ao fato de que este é produzido a partir de um ácido orgânico natural (Auras *et al.*, 2010). O ácido láctico pode ser sintetizado por um processo fermentativo de açúcares, obtidos a partir de fontes renováveis como a cana-de-açúcar (John *et al.*, 2009; Lunelli, 2010). Por esse motivo, o PLA pode ser considerado um produto *eco-friendly*, com características de biocompatibilidade adequadas para uso no corpo humano, sendo um material não - tóxico (Leong *et al.*, 2003; Chen *et al.*, 2006; Liu e Czernuszka, 2007; Fang *et al.*, 2005).

Os polímeros obtidos a partir do ácido láctico podem ser sintetizados por diferentes processos, visando produtos com ampla variedade de propriedades químicas e mecânicas, segundo a necessidade e aplicação (Auras *et al.*, 2004; Quynh *et al.*, 2008). Devido a suas excelentes características mecânicas e, especialmente, a sua capacidade de degradação e absorção no corpo humano, o PLA, seus copolímeros e blendas com outros polímeros, estão se tornando amplamente utilizados na engenharia tecidual para a restauração das funções de tecidos que foram prejudicadas (Chen *et al.*, 2002; Nair e Laurecin, 2007).

A fim de maximizar os benefícios das aplicações de dispositivos médicos produzidos a partir do PLA, é necessário compreender a relação entre as propriedades do polímero (matéria-prima), o processo de fabricação (técnicas convencionais ou prototipagem rápida) e o produto final com as características específicas desejadas.

Este capítulo proporciona uma revisão da produção de ácido láctico por fermentação de açúcares e suas características tais como a estrutura da molécula e

seus enantiómeros. Além disso, são apresentadas as propriedades do PLA e seus homopolímeros, bem como as diferentes rotas para sintetizá-lo (abertura de anéis e policondensação). Por último, é descrita a modelagem do processo de síntese deste polímero pela via de abertura de anéis.

3.2 Desenvolvimento

O desenvolvimento deste capítulo é apresentado a seguir, no artigo intitulado “*Poly(Lactic Acid) Synthesis for Application in Biomedical Devices – A Review*”, atualmente publicado *In Press* na revista, *Biotechnology Advances*, 2011, por uma indicação no *XIV International Biotechnology Symposium and Exhibition, 2010*.

POLY (LACTIC ACID) SYNTHESIS FOR APPLICATION IN BIOMEDICAL DEVICES – A REVIEW

Astrid J. R. Lasprilla^{1,2}, Guillermo A. R. Martinez^{1,2}, Betânia H. Lunelli¹
André L. Jardim^{1,2}, Rubens Maciel Filho^{1,2}

¹Laboratory of Optimization, Design and Advanced Control, School of Chemical Engineering, State University of Campinas, Campinas (SP), Brazil

²Institute of Biofabrication, Campinas (SP), Brazil
E-mail: maciel@feq.unicamp.br

Abstract. *Bioabsorbable polymers are considered a great alternative to the advancement and development of numerous applications in medicine. Poly (lactic acid) (PLA,) is one of the most promising biopolymers because of the fact that it is produced from a naturally occurring organic acid. Lactic acid can be made by fermentation of sugars obtained from renewable resources as such sugarcane. Therefore, PLA be an eco-friendly product with better features for use in the human body (nontoxicity). Lactic acid polymers can be synthesized by different processes so as to obtain products with an ample variety of chemical and mechanical properties. Due to their excellent biocompatibility and mechanical properties, PLA and their copolymers are becoming widely used in tissue engineering for function restoration of impaired tissues. In order to maximize the benefits of its use, it is necessary to understand the relationship between PLA material properties, the manufacture process and the final product with desired characteristics. In this paper, the lactic acid production by fermentation and the polymer synthesis such biomaterial are reviewed, this was done attempting to contribute to the critical knowledge development of the proper use of PLA for biomedical applications.*

Keywords: *Sugarcane, Lactic acid, Biomaterials, Renewable resources, Bioabsorbable polymer*

1. INTRODUCTION

The development of biomaterials (biodegradable and bioadsorbable) with the required characteristics to aid in the recovery of tissues damaged by accident or human disease is one of the greatest research challenges involving areas such as medicine and engineering. Biopolymers offer an alternative to traditional biocompatible materials (metallic and ceramic) and non-biodegradable polymers for a large number of applications (Chen et al., 2002; Nair and Laurecin, 2007; Peter et al., 1998; Temenoff and Mikos, 2000). Synthetic biodegradable poly-lactones such as poly (lactic acid) (PLA), poly-glycolic acid (PGA), and poly-caprolactone (PCL) as well as their copolymers are now commonly used in biomedical devices (Cheng et al, 2009) because of their excellent biocompatibility. These polymers are degraded by simple hydrolysis of the ester bonds, which does not require the presence of enzymes and in turn prevents inflammatory reactions. The hydrolytic products from such degradation process are then transformed into non-toxic subproducts that are eliminated through normal cellular activity and urine.

On the other hand, synthetic degradable polyesters have been used in surgery as suture materials and bone fixation devices for about three decades. Back in 1973, lactic acid and glycolic acid were proposed as degradable matrices for the sustained delivery of bioactive substances (Auras et al., 2004). Likewise, Poly (lactic acid) (PLA) has been demonstrated to be a suitable bioabsorbable polymer for fixation devices such as resorbable plates and screws (Lorenz, 2010). Bioabsorbable fixation devices have been extensively used as dissolvable suture meshes and recently, by orthopedic surgeons (Waris et al., 2004; Lovald et al., 2009). Absorbable systems are highly advantageous when compared with titanium plates or other metallic

implants given that they do not erode bone when placed in the human body (Dearnaley et al., 2007; Lindqvist et al., 1992). In addition, bioabsorbable devices do not require a second surgery to remove the implant -which reduces medical costs- and allow for the gradual recovery of tissue function as the device is degraded. Moreover, synthetic polymers can stimulate isolated cells to regenerate tissues and release drugs such as painkillers, anti-inflammatories and antibiotics, which has recently motivated their study as scaffolds for cell transplantation both in vitro and in vivo (Chen et al., 2007; Dai, et al., 2010; Kulkarni et al., 2010). Another desirable feature of resorbable plates is that, once resorbed, they do not block computed tomography (CT) scans, which facilitates subsequent medical imaging evaluations.

Regarding PLA, it has an extensive mechanical property profile and it is thermoplastic with high biocompatibility and biodegradability properties (Gupta et al, 2007; Auras et al., 2004). PLA is obtained from lactic acid and converted back to the latter one when hydrolytically degraded. Lactic acid is a naturally occurring organic acid that can be produced by fermentation of sugars obtained from renewable resources such as sugarcane. Therefore, PLA can be produced and used in an environmentally friendly cycle.

Although there are multiple ways to fabricate PLA, none of them is simple or easy to execute. PLA synthesis requires rigorous control of conditions (temperature and vacuum), the use of catalysts and long polymerization times, which implies high energy consumption. In order to understand reaction behavior, kinetic studies of PLA synthesis have been conducted by means of modern simulators, which offer a powerful tool to determine the optimal conditions for obtaining the desired PLA polymer for a specific application. This review summarizes information about the properties and applications of poly (lactic acid) as well as the different synthesis methods that are currently employed for its production. Lactic acid production process from renewable resources is also reviewed.

2. LACTIC ACID

Lactic acid (2-hydroxypropionic acid) is a simple chiral molecule that exists as two enantiomers, L- and D-lactic acid (Fig. 1), which differ in their effect on polarized light. The optically inactive D, L or meso form is an equimolar (racemic) mixture of D(-) and L(+) isomers (Gupta et al, 2007). It is considered the most potential monomer for chemical conversions because it contains a carboxylic group and a hydroxyl group (Varadarajan and Miller, 1999).

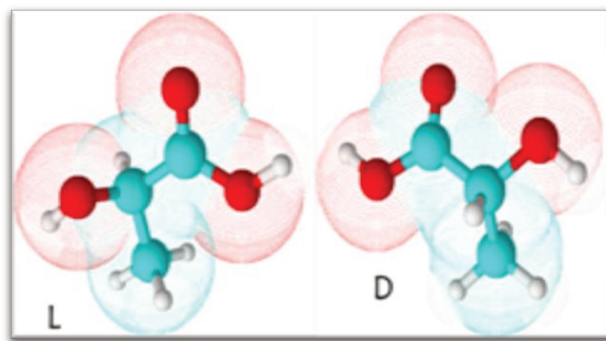

Figure 1: L- and D-lactic acid

Lactic acid production has a great worldwide demand due to its versatile applications in food, pharmaceutical, textile, leather, and chemical industries (John et al, 2009) and as monomer in the production of biodegradable polymers (PLA) (Adsul et al., 2007). Lactic acid can influence the metabolic function of cells in a variety of ways, as it can serve as an energy substrate and given its uncharged character and small size, it can permeate through the lipid membrane. Also, lactate is capable of entering

cells via the monocarboxylate transporter (MCT) protein shuttle system (Philp et al., 2005). Once inside the cell, lactate is converted to glucose, serving as a energy source in the Cori cycle. In addition to its role as an energy substrate for cells, lactic acid has been shown to have antioxidant properties that may serve to protect cells from damage due to free radicals that are naturally produced throughout the cell life cycle (Lampe et al, 2009).

On the other hand, lactic acid can be produced by fermentative or chemical synthesis. The chemical synthesis is mainly based on the hydrolysis of lactonitrile by a strong acid, where a racemic mixture of the two forms (D(-) and L(+)) lactic acid is produced. The biotechnological production of lactic acid has received significant interest, since it is an attractive process in terms of its environmental impact and its combination of low production cost from sugarcane fermentation, decreased fossil-based feedstock dependency, reduced CO₂ emission, biocatalyst use, and high product specificity (Lunelli et al, 2010) and production of optically pure L- or D-lactic acid, depending on the strain selected (Adsul et al, 2007).

Approximately 90% of the total lactic acid produced worldwide is made by bacterial fermentation and the remaining portion is produced synthetically by the hydrolysis of lactonitrile. The petrochemical scheme of monomer production was prevalent until 1990, when a more economic fermentation approach was developed (Gupta et al, 2007; Adsul et al., 2007).

The fermentation processes to obtain lactic acid can be classified according to the type of bacteria used. In the heterofermentative process, equimolar amounts of lactic acid, acetic acid, ethanol, and carbon dioxide are formed from hexose, whereas in the homofermentative process only lactic acid is produced from hexose metabolism (Auras et al., 2004; Thomas et al., 1979; Garvie, 1980; Holvendahl and Hahn-Hägerdal, 2000). Figure 2 shows the catabolic pathways for lactic acid production using lactic acid bacteria.

On the other hand, the carbon source for microbial production of lactic acid can be either sugar in pure form such as glucose, sucrose, lactose or sugar containing materials such as molasses, whey, sugarcane bagasse, cassava bagasse, and starchy materials from potato, tapioca, wheat and barley. Sucrose-containing materials such as molasses are commonly exploited raw materials for lactic acid production because they represent cheaper alternatives (John et al, 2007; Lunelli et al., 2010). Sugarcane bagasse is reported to be used as support for lactic acid production by *Rhizopus oryzae* and *Lactobacillus* in solid-state fermentation (SSF) by supplementing sugars or starch hydrolysates as carbon source (Rojan et al. 2005). Brazil is the world's largest sugarcane producer with 648'921.280 million tons per year in 2008, which generated about 130 million tons of bagasse on dry weight basis, according to FAO Statistics Division (2010).

3. POLY (LACTIC ACID)

PLA is a highly versatile biodegradable polymer, which can be tailor-made into different resin grades for processing into a wide spectrum of products. Because lactic acid is a chiral molecule existing in L and D isomers, the term “poly (lactic acid)” refers to a family of polymers: pure poly-L-(lactic acid) (PLLA), pure poly-D-(lactic acid) (PDLA), and poly-D,L-(lactic acid) (PDLLA) (Griffith, 2000). The L-isomer is a biological metabolite and constitutes the main fraction of PLA derived from renewable sources since the majority of lactic acid from biological sources exists in this form. Depending on the composition of the optically active L- and D, L-enantiomers, PLA can crystallize in three forms (α , β and γ) (Lim et al, 2008).

PLA was discovered in 1932 by Carothers (DuPont) who produced a low molecular weight product by heating lactic acid under vacuum. In 1954 Du Pont produced and patented a polymer with higher molecular weight. In 1968 Santis and Kovacs reported on the pseudo orthorhombic crystal structure of

PLLA, which was a left-handed helix conformation of the α -form (Södergard and Stolt, 2002). Lactic acid based polymers first became commercially successful as fiber materials for resorbable sutures. After this, a number of different prosthetic devices have been developed (Auras et al., 2004). Nowadays, PLA resins are approved by the US Food and Drug Administration (FDA) and European regulatory authorities for all food applications and some surgical applications such as drug releasing systems (Lampe et al., 2009).

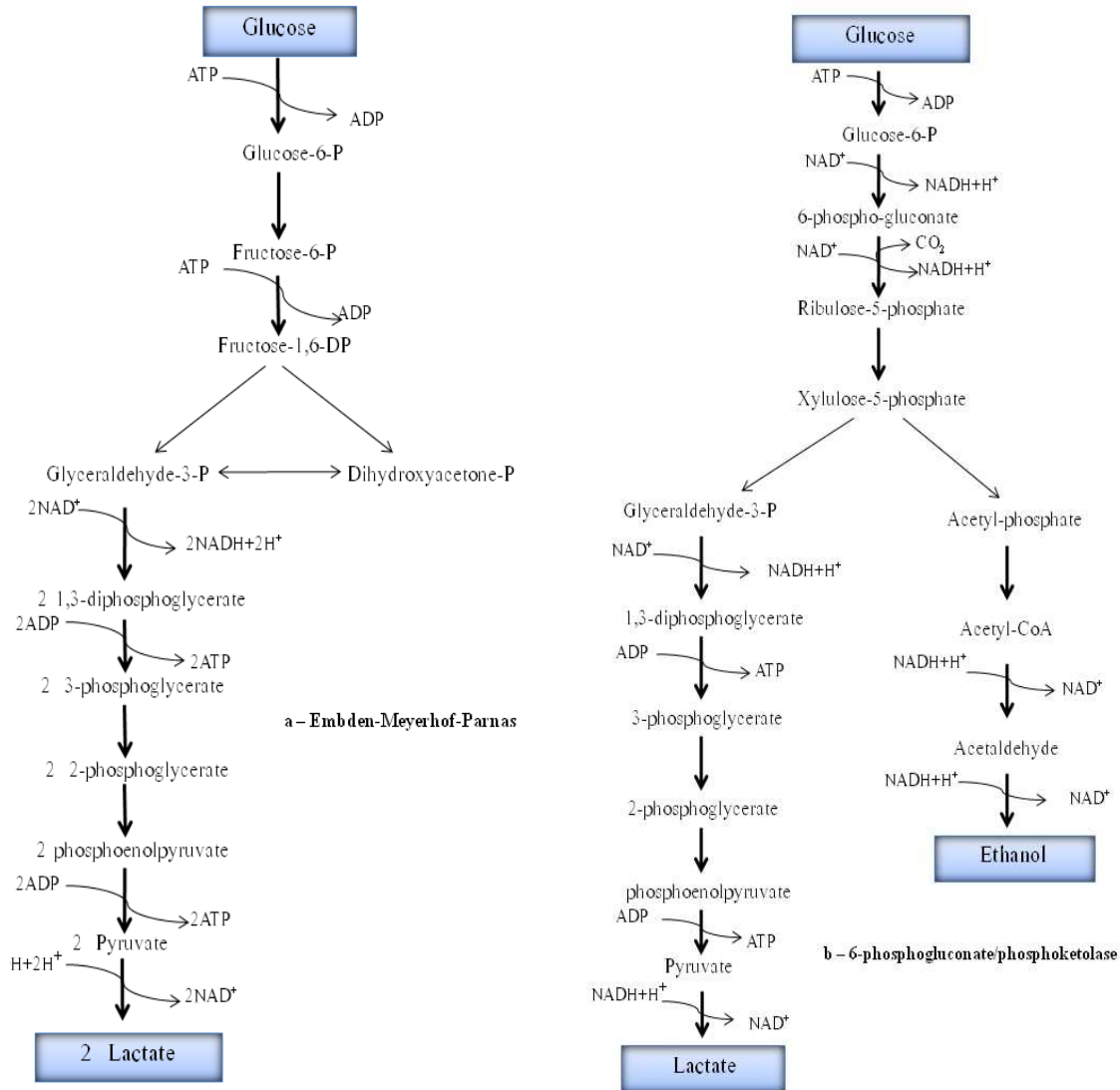

Figure 2. Metabolic pathways for lactic acid production
 (a) Embden-Meyerhof-Parnas; (b) 6-phosphogluconate/phosphoketolase (adapted from Axelsson, 2004).

Likewise, PLLA has gained great attention because of its excellent biocompatibility and mechanical properties. However, its long degradation times coupled with the high crystallinity of its fragments can cause inflammatory reactions in the body. In order to overcome this, PLLA can be used as a material combination of L-lactic and D, L-lactic acid monomers, being the latter rapidly degraded without formation of crystalline fragments during this process (Hirata and Kimura, 2008).

The chemistry of PLA involves the processing and polymerization of lactic acid monomer. PLA is a chiral polymer containing asymmetric carbon atoms with a helical conformation. It has stereocenters in its repeating unit, which can exhibit two structures of maximum order, that is, isotactic and syndiotactic. Isotactic polymers contain sequential stereocenters of the same relative configuration while syndiotactic polymers contain sequential stereocenters of opposite relative configuration (Auras et al., 2010). Isotactic and optically active PLLA and PDLA are crystalline, whereas relatively atactic and optically inactive PDLLA is amorphous (Bouapao et al, 2009). Monomer dyads in the PLA chain may contain identical stereocenters (L:L or D:D) or enantiomeric stereocenters (L/D).

3.1 Poly (lactic acid) properties

PLAs properties have been the subject of extensive research (Malmgren et al, 2006). The stereochemistry and thermal history have direct influence on PLA crystallinity, and therefore, on its properties in general. PLA with PLLA content higher than 90% tends to be crystalline, while the lower optically pure is amorphous. The melting temperature (T_m), and the glass transition temperature (T_g) of PLA decrease with decreasing amounts of PLLA (Auras et al., 2010). Physical characteristics such as density, heat capacity, and mechanical and rheological properties of PLA are dependent on its transition temperatures (Henton et al, 2005).

For amorphous PLA, the glass transition temperature (T_g) is one the most important parameters since dramatic changes in polymer chain mobility take place at and above T_g . For semicrystalline PLA, both T_g and melting temperature (T_m) are important physical parameter for predicting PLA behaviour (Auras et al., 2004; Yamane and Sasai, 2003; Bouapao et al., 2009). The melt enthalpy estimated for an enantiopure PLA of 100% crystallinity (ΔH_0m) is 93 J/g, it is the value most often referred to in the literature although higher values (up to 148 J/g) also have been reported (Södergard and Stolt, 2002).

The density of amorphous and crystalline PLLA has been reported as 1.248 g ml⁻¹ and 1.290 g ml⁻¹ respectively. The density of solid polylactide was reported as 1.36 g cm⁻³ for l-lactide, 1.33 g cm⁻³ for meso-lactide, 1.36 g cm⁻³ for crystalline polylactide and 1.25 g cm⁻³ for amorphous polylactide (Auras et al., 2004). In general, PLA products are soluble in dioxane, acetonitrile, chloroform, methylene chloride, 1,1,2-trichloroethane and dichloroacetic acid. Ethyl benzene, toluene, acetone and tetrahydrofuran only partly dissolve polylactides when cold, though they are readily soluble in these solvents when heated to boiling temperatures. Lactid acid based polymers are not soluble in water, alcohols as methanol, ethanol and propylene glicol and unsubstituted hydrocarbons (e.g. hexane and heptane). Crystalline PLLA is not soluble in acetone, ethyl acetate or tetrahydrofuran (Nampoothiri et al, 2010). Some of PLAs properties are cited in Table 1.

Table 1: Lactid acid polymers properties (adapted from Nampoothiri et al, 2010 and Södergard and Stolt, 2002).

Lactic acid polymers	Glass transition temperature T_g (°C)	Melting temperature T_m (°C)	Density (g/cm ³)	Good solubility in solvents
<i>PLLA</i>	<i>55-80</i>	<i>173-178</i>	<i>1.290</i>	<i>Chloroform, furan, dioxane and dioxolane.</i>
<i>PDLLA</i>	<i>43-53</i>	<i>120-170</i>	<i>1.25</i>	<i>PLLA solvents and acetone, ethyl lactate, tetrahydrofuran, ethyl acetate, dimethylsulfoxide, N,N xylene and dimethylformamide.</i>
<i>PDLA</i>	<i>40-50</i>	<i>120-150</i>	<i>1.248</i>	

Few stereocomplex such as PLA can be produced by enantiomers with the identical chemical composition but different steric structure. Since discovery in 1987, the stereocomplex between poly-L-lactide (PLLA) and poly-D-lactide (PDLA) have been intensively studied by preparations, structural, functional properties and applicability (Quynh et al, 2008). With special catalysts isotactic and syndiotactic content with different enantiometric units can be controlled then PLA properties (Gupta et al, 2007).

PLA also can be tailored by formulation involving co-polymerizing of the lactide with other lactones-type monomers, a hydrophilic macro-monomers (polyethylene glycol (PEG)), or other monomers with functional groups (such as amino and carboxylic groups, etc.), and blending PLA with other materials (Cheng et al, 2009). Blending can radically alter the resultant properties, which depend sensitively on the mechanical properties of the components as well as the blend microstructure and the interface between the phases (Broz et al, 2003). Broz et al. (2003) prepared series of blends of the biodegradable polymers poly-D,L-(lactic acid) and poly(ϵ -caprolactone) by varying mass fraction across the range of compositions. Polymers made from ϵ -caprolactone are excellent drug permeation products. However, mechanical and physical properties need to be enhanced by copolymerization or blending (Auras et al., 2004; Wang et al., 1999).

PLA degrades primarily by hydrolysis, after several months exposure to moisture. Polylactide degradation occurs in two stages. First, random non-enzymatic chain scission of the ester groups leads to a reduction in molecular weight. In second stage, the molecular weight is reduced until the lactic acid and low molecular weight oligomers are naturally metabolized by microorganisms to yield carbon dioxide and water (Oyama et al. 2009; Auras et al., 2004).

The polymer degradation rate is mainly determined by polymer reactivity with water and catalysts. Any factor which affects the reactivity and the accessibility, such as particle size and shape, temperature, moisture, crystallinity, % isomer, residual lactic acid concentration, molecular weight, water diffusion and metal impurities from the catalyst, will affect the polymer degradation rate (Auras et al., 2004; Cha and Pitt, 1990; Bleach et al., 2001; Drumright et al., 2000; Tsuji and Ishida, 2003). The in vivo and in vitro degradation have been evaluated for polylactide surgical implants. In vitro studies showed that the pH of the solution does play a role in the in vitro degradation and that an in vivo study can be used as a predictor of the in vivo degradation of PLA (Mainil-Varlet et al., 1997; Auras et al., 2004).

3.2 Poly (lactid acid) synthesis

Polymers based on lactic acid (PLA) are a most promising category of polymers made from renewable resources (Auras et al., 2010). PLA can be prepared by different polymerization process from lactic acid including: polycondensation, ring opening polymerization and by direct methods like azeotropic dehydration and enzymatic polymerization (Garlotta, 2002). Currently, direct polymerization and ring opening polymerization are the most used production techniques. Figure 3 shows the main methods for PLA synthesis.

* Modelagem e simulação do processo de produção de PLA (poli-ácido láctico) obtido a partir de fontes renováveis para uso biomédico *

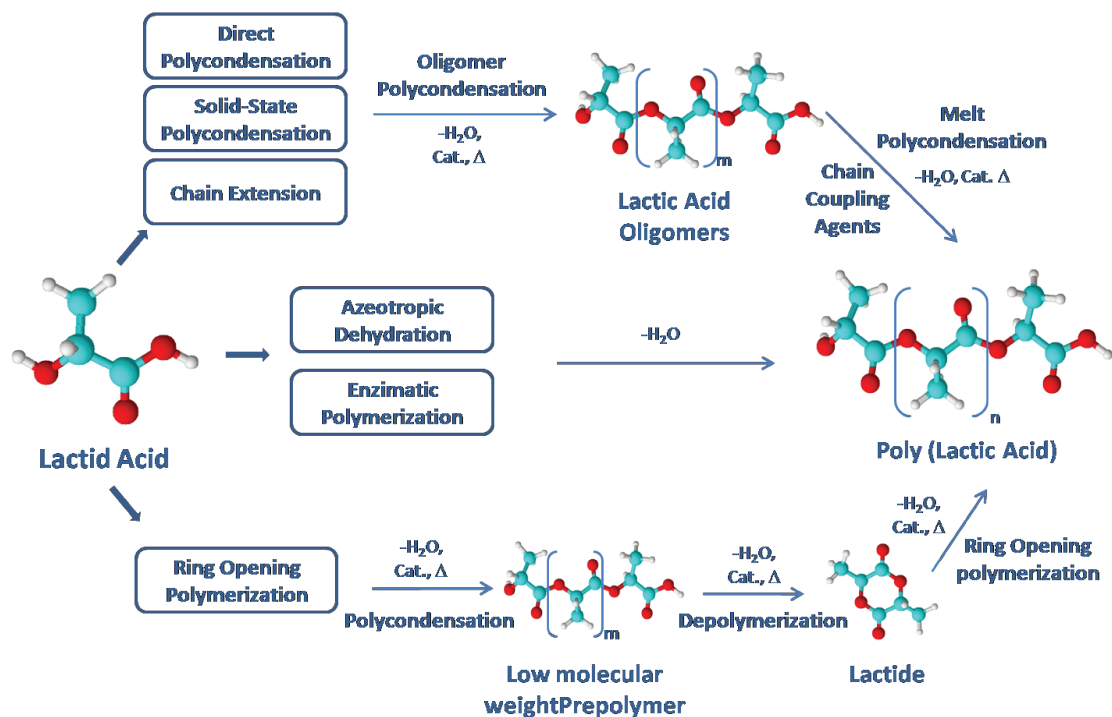

Figure 3. Synthesis methods for Poly (lactic acid) (adapted from Garlotta, 2002 and Auras et al., 2010).

Condensation polymerization (polycondensation) includes solution polycondensation and melts polycondensation, and is the least expensive route. However, it is very difficult to obtain a solvent-free high molecular weight poly (lactic acid) for these routes (Auras et al., 2004). In direct polycondensation, solvents and/or catalysts is used under high vacuum and temperatures for the removal of water produced in the condensation. The resultant polymer is a low to intermediate molecular weight material, which can be used as is, or coupled with isocyanates, epoxides or peroxide to produce a range of molecular weights (Gupta et al, 2007). Achmad et al. (2009), report the synthesis of PLA by direct polymerization without catalysts, solvents and initiators by varying the temperature from 150 to 250°C and the pressure from atmosphere pressure to vacuum for 96 h. The Mitsui Toatsu Chemical Company polymerized poly-DL-(lactic acid) (PDLA) using direct solution polycondensation, in which lactic acid, catalysts, and organic solvent with high boiling point were mixed in a reactor. The resultant product shows a molecular weight (MW) of about 300000 (Cheng et al., 2009).

Polycondensation method produces oligomers with average molecular weights several tens of thousands and other side reactions also can occur, such transesterification, resulting in the formation of ring structures as the lactide. These side reactions have a negative influence on properties of the final polymer (Auras et al., 2010). That subproducts production cannot be excluded, but can be controlled by the use of different catalysts and functionalization agents, as well as by varying the polymerization conditions (Mehta et al, 2005).

Lactid acid direct condensation is carry out in three stages: removal of the free water, oligomer polycondensation and metl condensation of high molecular weight PLA. In first and third estages , the removal of water is the rate-determining step. For the second one, the rate-determining step is the chemical reaction, which depends on the catalyst used (Auras et al., 2010). The direct polycondensation of lactic acid in bulk is not applied on a greater scale, because of the competitive reaction of lactide formation and the simultaneously occurring degradation process (Dutkiewicz et al, 2003).

In the sequential melt/solid-state polycondensation, besides the three mentioned steps (i.e., removal of the free water content, oligomer polycondensation, and melt polycondensation) is utilized an additional fourth stage. In the fourth stage, the melt-polycondensated PLA is cooled below its melting temperature, followed by particle formation, which then subjected to a crystallization process (Auras et al., 2010; Fukushima and Kimura, 2008).

Chain extension is effective way to achieve high molecular weight lactic acid-based polymers by polycondensation (Gu et al, 2008). In this method the intermediate low molecular weight is treat polymers with chain extenders which link the low molecular weight prepolymer into a polymer of high molecular weight. Gu et al, 2008, obtained polymer had a M_n of 27 500 g mol⁻¹ after 40 min of chain extension at 180°C using 1,6-hexamethylene diisocyanate as the chain extender.

Ring-opening polymerization (ROP) is the most commonly route to achieve high molecular weight (Auras et al., 2010). This method is carried out by of the ring opening of the lactic acid cyclic dimer (lactide) in the presence catalyst following three steps: polycondensation, depolymerization and ring opening polymerization (see Figure 3). This route requires additional steps of purification which is relatively complicated and expensive. Catalytic ring-opening polymerization of the lactide intermediate results in PLA with controlled molecular weight (Kim et al., 2009). By controlling residence time and temperatures in combination with catalyst type and concentration, it is possible to control the ratio and sequence of D- and L-lactic acid units in the final polymer (Gupta et al, 2007).

In the other hand, ring-opening polymerization of lactide can be carried out in melt, bulk, or in solution and by cationic, anionic, and coordination-insertion mechanisms depending on the catalyst. Various types of initiators have been successfully tested, but among them, stannous octoate is usually preferred because it provides high reaction rate, high conversion rate, and high molecular weights, even under rather mild polymerization conditions (Mehta, 2005).

Azeotropic dehydration is a direct method for synthesis of high molecular weight PLA (Garlotta, 2002). In this route, the removal of water formed from the reaction medium thus becomes easier and a higher molecular weight of the PLA is achievable (Auras et al., 2010). Kim and Woo, 2002 obtained PLA of M_v about 33 000 through the azeotropic dehydration at 138 °C for 48–72 h using a molecular sieve as a drying agent and m-xylene as a solvent.

Enzymatic polymerization emerges as one of the most viable alternatives and is an environmentally benign method that can be carried out under mild conditions and can provide adequate control of the polymerization process (Cheng et al, 2009), but the literature about enzymatic polymerization is poor. Chanfreau et al, 2010, reported the enzymatic synthesis of poly-L-lactide using a liquid ionic (1-hexyl-3-ethylimidazolium hexafluorophosphate [HMIM][PF6]) mediated by the enzyme lipase B from *Candida antarctica* (Novozyme 435). The highest PLLA yield (63%) was attained at 90°C with a molecular weight (M_n) of 37.8 9 103 g/mol (Chanfreau et al, 2010).

3.3 Kinetics and modeling of PLA

In contrast with the extensive experimental work about polymerization reactions, only a few publications focus on the mathematical modeling of such reactions, or at least on the evaluation of the corresponding rate coefficients (Yu et al, 2009). PLA production can be carried out from both lactic acid and its dimer cyclic (lactide) as the monomer.

The use of lactide as monomer or intermediate product leads to a "Ring Opening Polymerization" (ROP), which refers to the opening of dimer rings in order to form polymer chains. Several authors have worked in the modeling of catalyzed lactide ROP (Puaux et al, 2007; Yu et al, 2009). According to Yu et al. 2009,

the first systematic kinetic analysis of PLA ROP catalyzed by Sn(Oct)₂ was reported by Eenink in 1987, although impurities were not accounted for in such kinetic models. Later on, Zhang et al, 1994, found that hydroxyl and carboxylic acids strongly affect reaction rates. On the other hand, reversible reactions were included in the lactide polymerization model proposed by Witzke et al. (1997). More recently, researchers have developed models based on the cationic mechanism, which involves irreversible initiation and propagation steps as well as irreversible chain transfer to monomer and impurities (Puaux et al., 2007 and Mehta et al., 2007)

The following reactions (R1 –R3) represent the polymerization models for PLA synthesis by ring opening proposed by Mehta (2007). This type of reaction is also considered a chain-growth polymerization, and therefore, it is divided into three mains steps: Initiation, propagation and termination, having each one of them a different rate constant.



where k_0 is the initiation rate constant, M is the monomer, I is the initiator and P₁ is the activated polymer of one unit. P_j is the active polymer chain of j units and the rate constant of propagation reaction is k_j , which refers to the jth propagation step on a chain. M_j is the deactivated polymer of j repeat units that will not react any further, and k_t is the termination rate constant. Regarding the termination step, Metha, 2007, proposed two alternative ways, being water-like impurities considered in the first method and intermolecular chain transfers accounted for in the second one. The mass balance equations for a batch reactor were written for the above kinetic scheme as follows:

$$\frac{d[M]}{dt} = -[M] \left\{ k_0[I] + \sum_{j=1}^n k_j[P_j] + \sum_{j=1}^n k_{tj}[P_j] \right\} \quad (Eqn.1)$$

$$\frac{d[I]}{dt} = -k_0[I][M] \quad (Eqn.2)$$

$$\frac{d[P_1]}{dt} = k_0[I][M] - k_1[P_1][M] + \sum_{j=2}^n k_{tj}[P_j][M] \quad (Eqn.3)$$

$$\frac{d[P_j]}{dt} = [M] \left\{ k_{(j-1)}[P_{j-1}] - k_j[P_j] - k_{tj}[P_j] \right\}, j > 1 \quad (Eqn.4)$$

Seavey and Liu developed a PLA synthesis simulation in Polymers Plus (ASPEN PLUS®) with the polymerization mechanism described in the following equations. The reactions (R4 – R6) represent the oligomers oblation; they are esterification reactions that produce low molecular weight PLA molecules and their respective reversible reactions (hydrolysis).

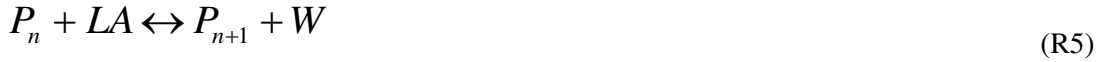
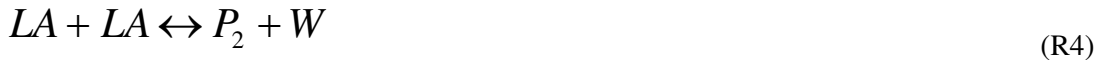

where LA is lactic acid, W is water and, P_n is an oligomer with n acid lactic units. When n=2 the oligomer is called linear dimer. In the presence of the appropriate stannous catalyst, the two end groups of the linear oligomer can also react with each other forming a closed ring structure, reaction that is especially favorable for linear dimers because of the high stability of the resulting molecule (Lactide). The reaction (R7) represents this reaction and its reverse reaction (hydrolysis).



where P₂ is a linear dimer, C₂ is a cyclic dimer and W is water. In the polymerization steps, lactide is polymerized through ring opening and ring addition reactions in the presence of catalyst and trace amounts of water and lactic acid. This is represented in reactions (R8 – R9).



Due to the absence of large amounts of water and lactic acid, the P_n molecule has a high repeat unit amount, which in turn leads to a high molecular weight polymer Seavey and Liu, 2008 used the step-growth reaction kinetics model in Polymers Plus to predict the reaction rates involved in each step of the PLA process. According to Seavey and Liu, 2008, the step-growth model generates a reaction network based on user-specified functional groups. In this way, the role of the user is limited to defining the structure of the reactants in terms of nucleophilic and electrophilic functional groups in order to select the type of reactions to be generated by the model, which is able to find all possible ways in which the various species can react with each other. This implemented model generates forward- and reverse- condensation reactions (e.g., esterification and hydrolysis) as well as subsequent rearrangement reactions (polymerization) (Seavey and Liu, 2008).

4. PLA BIOMEDICAL APPLICATIONS

During the last decades, biodegradable materials have been studied extensively for medical applications, because they have advantages over nondegradable biomaterials include eliminating the need to remove implants and providing longterm biocompatibility.

The most common synthetic biodegradable polymers in medical applications are the poly(α-hydroxyacid)s, including poly(glycolic acid) (PGA), poly (lactic acid) (PLA), and polydioxanone (PDS) (Middleton and Tipton, 2000). Poly (lactic acid) offers unique features of biodegradability, biocompatibility, thermoplastic processability and eco-friendliness that offer potential applications as

** Modelagem e simulação do processo de produção de PLA (poli-ácido láctico) obtido a partir de fontes renováveis para uso biomédico **

commodity plastics, as in packaging, agricultural products, disposable materials and medical textile industry. Because of its favorable characteristics, PLA has been utilized as ecological material as well as surgical implant material and drug delivery systems, and also as porous scaffolds for the growth of neo-tissue (Gupta et al., 2007; Yamane and Sasai, 2003). The use of poly (lactic acid) in these applications is not based solely on its biodegradability nor because it is made from renewable resources. PLA is being used because it works very well and provides excellent properties at a low price (Drumright et al., 2000). Various devices have been prepared from different PLA types including degradable sutures, drug releasing microparticles, nanoparticles, and porous scaffolds for cellular applications.

The diversification of PLA applications is such that a single polymer may prove useful in many applications by simple modifications of its physical-chemical structure. In many cases the polymer can be blended or copolymerized with other polymeric or non-polymeric components to achieve the desired behavior (Gupta et al, 2007; Cheng et al, 2009). The surface properties of materials play a critical role in determining their applications, especially for biomaterials in biocompatibility. Different surface modification strategies, such as physical, chemical, plasma, and radiation induced methods, have been employed to create desirable surface properties of PLA biomaterials.

Because biodegradable polymers implants temporarily remain in the body and disappear upon degradation, and it is no necessary a secondary operation to remove them after the defect site is repaired, they have an important application in the medical field. As a fiber the PLLA is not suitable for sutures, due to its degradation rate is very slowly. On the other hand, in applications that require long retention of the strength, such as ligament and tendon reconstruction, and stents for vascular and urological surgery, PLLA fibers are the preferred material (Durselen et al. 2001). Three-dimensional porous scaffolds of PLA have been created for culturing different cell types, using in cell-based gene therapy for cardiovascular diseases; muscle tissues, bone and cartilage regeneration and other treatments of cardiovascular, neurological, and orthopedic conditions (Coutu, et al., 2009; Kellomäki et al., 2000; Papenburg et al. 2009). Osteogenic stem cells seeded on scaffolds of this material and implanted in bone defects or subcutaneously can recapitulate both developmental processes of bone formation: endochondral ossification and intramembranous ossification (Behonick et al., 2007; Caplan, 2009). Due to the high strength of PLLA mesh, it is possible to create 3D structures such as trays and cages (Kinoshita et al., 2003).

An exciting application, for which the PLA offer tremendous potential, is bone fixation devices, due to the metallic fixations have several disadvantages. Recently, biodegradable materials have been replacing metallic ones for the fixation of fractured bones in the forms of plates, pins, screws, and wires. Since materials for bone fixation require high strength, similar to that of bone, PLA has a large application in this field.

One application of PLLA in the form of injectable microspheres is temporary fillings in facial reconstructive surgery. PLLA microspheres have also been used as an embolic material in transcatheter arterial embolization, which is an effective method to manage arteriovenous fistula and malformations, massive hemorrhage, and tumors (Imola and Schramm, 2002; Eppley et al, 2004). Microspheres and microcapsules have been widely applied in drug delivery systems (DDS) for the prolonged administration of a wide variety of medical agents such as contraceptives, narcotic antagonists, local anesthetics, and vaccines. DDS with peptides and proteins have also gathered much attention, since they are specifically effective with comparatively low doses (Tan et al., 2010). Release of drugs from these systems is based on several mechanisms that include diffusion and polymer degradation (hydrolysis or enzymatic degradation) (Valantin et al, 2003).

5. CONCLUSION

According to the text reported above can perceive that the biodegradable and bioabsorbable polymer synthesis from renewable resources for biomedical devices application has attracted much attention of researchers and industry. Lactic acid, a product of industrial importance for production of several chemicals and as monomer for PLA production, can be produced by fermentation of the sucrose contained in sugarcane molasses, a by-product of sugar manufacture, and from sugarcane bagasse that is a waste available in abundance in Brazil. PLA is a well-known synthetic polymer, and it is one of the most promising biodegradable polymers used for various biomedical applications due to its biocompatibility and biodegradability. The diversification of PLA applications is such that a single polymer may prove useful in many applications by simple modifications of its physical-chemical structure, resultant of chirality of lactic acid molecule with two asymmetric centers existing in four different forms.

ACKNOWLEDGEMENTS

The authors wish to acknowledge the financial support provide by FAPESP (The Scientific Research Foundation for the State of São Paulo), CNPq (National Council for Scientific and Technological Development) and INCT-BIOFABRIS (National Institute of Science and Technology in Biofabrication).

REFERENCES

- Achmad F et al. (2009). Synthesis of polylactic acid by direct polycondensation under vacuum without catalysts, solvents and initiators. *Chem. Eng. J.*; 151: 342-350.
- Adsul MG et al. (2007). Lactic acid production from waste sugarcane bagasse derived cellulose. *Green Chem.*; 9: 58-62.
- Auras R et al. (2004). An overview of polylactides as packaging materials. *Macromol. Biosci.*; 4: 835-864.
- Auras R et al.. *Poly(Lactic Acid):Synthesis, Structures, Properties, Processing, and Application*. New Jersey: Jhon Wiley & Sons, Inc; 2010.
- Behonick DJ et al. (2007). Role of matrix metalloproteinase 13 in both endochondral and intramembranous ossification during skeletal regeneration. *PLoS ONE*; 2: 1-10.
- Bleach NC et al. (2001). Effect of filler type on the mechanical properties of self-reinforced polylactide-calcium phosphate composites. *J. Mater. Sci.:Mater.Med.*; 12: 911-915.
- Bouapao L et al. (2009). Crystallization, spherulite growth, and structure of blends of crystalline and amorphous poly(lactide)s. *Polyme.*; 50: 4007-4017.
- Broz ME et al. (2003). Structure and mechanical properties of poly(D, L -lactic acid)/poly(α -caprolactone) blends. *Biomater.*; 24: 4181-4190.
- Caplan AI (2009). New era of cell-based orthopedic therapies. *Tissue Eng. Part B: Rev.*; 15: 195-200.
- Cha Y and Pitt CG (1990). The biodegradability of polyester blends. *Biomater.*; 11: 108-112.
- Chanfreau S et al. (2010). Enzymatic synthesis of poly-L-lactide and poly-L-lactide-co-glycolide in an ionic liquid. *Bioprocess Biosyst. Eng.*; 33:629-638.
- Chen G et al. (2002). Scaffold design for tissue engineering. *Macromol. Biosci.*; 2: 67-77.
- Chen Y et al. (2006). PLLA scaffolds with biomimetic apatite coating and biomimetic apatite/collagen composite coating to enhance osteoblast-like cells attachment and activity. *Surf. Coat. Technol.*; 201: 575-580.
- Cheng Y et al. (2009). Polylactic acid (PLA) synthesis and modifications: a review. *Front. Chem. China*; 4: 259-264.
- Coutu DL et al. (2009). Three-dimensional porous scaffolds at the crossroads of tissue engineering and cell-based gene therapy. *J. Cell. Biochem.*; 108: 537-546.

** Modelagem e simulação do processo de produção de PLA (poli-ácido láctico) obtido a partir de fontes renováveis para uso biomédico **

- Dai W et al. (2010). The influence of structural design of PLGA/collagen hybrid scaffolds in cartilage tissue engineering polymers. *Biomater.*; 31: 2141-2152.
- Dearnaley G et al. (2007). The use of thin layer activation to evaluate ion beam surface treatments of orthopaedic implant materials. *Surf. Coat. Technol.*; 201: 8070-8075.
- Drumright RE et al. (2000). Polylactic acid technology. *Adv. Mater.*; 12: 1841-1846.
- Duek EAR et al. (1999). In vitro study of poly(lactic acid) pin degradation. *Polym.*; 49: 6465-6473.
- Durselen L et al. (2001). Resorbable polymer fibers for ligament augmentation. *J. Biomed. Mater. Res.*; 58: 666-672.
- Dutkiewicz S et al. (2003). Synthesis of Poly(L+) Lactic Acid by Polycondensation Method in Solution. *Fibres Text. Eastern Eur.*; 11: 66-70.
- Eppley BL et al. (2004). Resorbable PLLA-PGA plate and Screw Fixation in pediatric Craniofacial surgery: Clinical Experience in 1883 patients. *Plast. Reconstr. Surg.*; 114: 850-856.
- FAO Statistics Division (2010). Available at: <http://www.faostat.fao.org>. Accessed: April 2010.
- Fukushima K and Kimura Y (2008). An Efficient Solid-State Polycondensation Method for Synthesizing Stereocomplexed Poly(Lactic Acid)s with High Molecular Weight. *J. Polym. Sci. Part A: Polym. Chem.*; 46: 3314-3322.
- Garlotta D (2001). A literature review of poly(lactic acid). *J. Polym. Environ.*; 9: 63-84.
- Garvie EL (1980). Bacterial lactate dehydrogenases. *Microbiol. Rev.*; 44: 106-139.
- Griffith LG (2000). Polymeric biomaterials. *Acta Mater.*; 48: 263-277.
- Gu SY et al. (2008). Synthesis and characterization of biodegradable lactic acid-based polymers by chain extension. *Polym. Int.*; 57:982-986.
- Gupta B et al. (2007). Poly(lactic acid) fiber: An overview. *Prog. Polym. Sci.*; 34: 455-482.
- Henton DE et al.. Polylactic acid Technology. In: Mohanty AK. Natural Fibers, Biopolymers and Biocomposites. CRC Press; 2005. p 528-569
- Hofvendahl K and Hahn-Hägerdal B (2000). Factors affecting the fermentative lactic acid production from renewable resources. *Enzyme Microb. Technol.*; 26: 87-107.
- Ignjatovic N and Uskokovic D (2004). Synthesis and application of hydroxyapatite/polylactide composite biomaterial. *Appl. Surf. Sci.*; 238: 314-319.
- Imola MJ and Schramm VL (2009). Resorbable Internal Fixation in Pediatric Cranial Base Surger. *Laryngoscope*; Volume 112: 1897-1901.
- John RP et al. (2007). Fermentative production of lactic acid from biomass: an overview on process developments and future perspectives. *Appl. Microbiol. Biotechnol.*; 74: 524-534.
- John RP et al. (2009). Direct lactic acid fermentation: Focus on simultaneous saccharification and lactic acid production. *Biotechnol. Adv.*; 27: 145-152.
- Kellomäki M et al. (2000). Bioabsorbable scaffolds for guided bone regeneration and generation. *Biomater.*; 21: 2495-2505.
- Kim E et al. (2009). Characteristics of heterogeneous titanium alkoxide catalysts for ring-opening polymerization of lactide to produce polylactide. *J. Mol. Catal. A: Chem.*; 298: 36-39.
- Kim KW and Woo SI (2002). Synthesis of High-Molecular-Weight Poly(L-lactic acid) by Direct Polycondensation. *Macromol. Chem. Phys.* 203: 2245-2250.
- Kinoshita Y et al. (2003). Reconstruction of jawbones using poly(L- lactic acid) mesh and transplantation of particulate cancellous bone and marrow: Long-term observation of 40 cases. *Int. J. Oral Maxillofac. Surg.*; 32:117.
- Kulkarni M et al. (2010). Liposomal gene delivery mediated by tissue-engineered scaffolds. *Trends Biotechnol.*; 28: 28-36.
- Lampe K J et al. (2009). Impact of lactic acid on cell proliferation and free radical-induced cell death in monolayer cultures of neural precursor cells. *Biotechnol. Bioeng.*; 103: 1214-1223.
- Lim LT et al. (2008). Processing technologies for poly(lactic acid). *Prog. Polym. Sci.*; 33: 820-852.
- Lindqvist C et al. (1992). Erosion and heterotopic bone formation after alloplastic temporomandibular joint reconstruction. *J. Oral Maxillofac. Surg.*; 50: 942-949.

- Lorenz W (2010). Walter Lorenz Surgical Inc. Available at: www.lorenzsurgical.com. Accessed: April 2010.
- Lovald ST (2009). Mechanical Design Optimization of Bioabsorbable Fixation Devices for Bone Fractures. *J. Craniofacial Surg.*; 20: 389-398.
- Lunelli BH et al. (2010). Production of lactic acid from sucrose: strain selection, fermentation, and kinetic modeling. *Appl. Biochem. Biotechnol.*; 161: 227-237.
- Mainil-Varlet P (1997). Effect of in vivo and in vitro degradation on molecular and mechanical properties of various low-molecular-weight polylactides. *J. Biomed. Mater. Res.*; 36: 360-380.
- Malmgren T et al. (2006). Characterization of poly(lactic acid) by size exclusion chromatography, differential refractometry, light scattering and thermal analysis. *J. Therm. Anal. Calorim.* 83: 35-40.
- Mehta R. Modeling and Simulation of Poly(Lactic Acid) Polymerization. Thesis (PhD), Thapar Institute of Engineering and Technology, India; 2007.
- Mehta R et al. (2005). Synthesis of Poly(Lactic Acid): A Review. *Polym. Rev.*; 45: 325-349.
- Middleton JC and Tipton AJ (2000). Synthetic biodegradable polymers as orthopedic devices. *Biomaterial.*; 21: 2335-2346
- Nair LS and Laurencin CT (2007). Biodegradable Polymers as Biomaterials. *Prog. Polym. Sci.*; 32: 762-798.
- Nampoothiri KM et al. (2010). An overview of the recent developments in polylactide (PLA) research. *Biores. Technol.*; 101:8493-8501.
- Nejati E et al. (2008). Synthesis and characterization of nano-hydroxyapatite rods/poly(l-lactide acid) composite scaffolds for bone tissue engineering. *Compos. Part A: Appl. Sci. Manuf.*; 39: 1589-1596.
- Oyama HT et al. (2009). Rapid controlled hydrolytic degradation of poly(l-lactic acid) by blending with poly(aspartic acid-co-l-lactide). *Polym. Degrad. Stab.*; 94: 1419-1426.
- Papenburg BJ et al. (2009). Development and analysis of multi-layer scaffolds for tissue engineering. *Biomater.*; 30: 6228-6239.
- Peter SJ et al. (1998). Polymers concepts in tissue engineering. *J. Biomed. Mater. Res.*; 43: 422-427.
- Philp A et al. (2005). Lactate – a signal coordinating cell and systemic function. *J. Exp. Biol.*; 208: 4561-4575.
- Puau JP et al. (2007). A Study of L-Lactide Ring-Opening Polymerization Kinetics. *Macromol. Symp.*; 259: 318–326
- Quynh TM et al. (2008). The radiation crosslinked films based on PLLA/PDLA stereocomplex after TAIC absorption in supercritical carbon dioxide. *Carbohydr. Polym.*; 72: 673-681.
- Rojan PJ et al. (2005). L-Lactic acid production using *Lactobacillus casei* in solid-state fermentation. *Biotechnol. Lett.*; 27: 1685–1688.
- Seavey K and Liu YA. Step-Growth Polymerization Process Modeling and Product Design. New Jersey: Jhon Wiley & Sons, Inc; 2008.
- Södergard A and Stolt M (2002) Properties of lactic acid based polymers and their correlation with composition. *Prog. Polym. Sci.*; 27: 1123-1163.
- Tan ML et al. (2010). Recent developments in liposomes, microparticles and nanoparticles for protein and peptide drug delivery. *Peptides*; 31: 184-193.
- Temenoff JS and Mikos AG (2000). Review: tissue engineering for regeneration of articular cartilage. *Biomater.*; 21: 431-440.
- Thomas TD et al. (1979). Change from homo-to-heterolactic fermentation by *Streptococcus lactis* resulting from glucose limitation in anaerobic chemostat cultures. *J. Bacteriol.*; 138: 109-117.
- Tsuji H and Ishida T (2003). Poly(L-lactide).X. Enhanced surface hydrophilicity and chain scission mechanisms of poly(L-lactide) film in enzymatic, alkaline, and phosphate-buffered solutions. *J. Appl. Polym. Sci.*; 87: 1628-1633.
- Valantin MA et al. (2003). Polylactic acid implants (New-Fill) to correct facial lipotrophy in HIV-infected patients: results of the open-label study. *AIDS*; 17: 2471–2477.
- Varadarajan S and Miller DJ (1999). Catalytic upgrading of fermentation-derived organic acids. *Biotechnol. Prog.*; 15: 845-854.

** Modelagem e simulação do processo de produção de PLA (poli-ácido láctico) obtido a partir de fontes renováveis para uso biomédico **

- Wang S et al. (1999). Oxygen permeability of biodegradable copolycaprolactones. *Polym. Adv. Technol.*; 10: 282-286.
- Waris E et al. (2004) Bioabsorbable fixation devices in trauma and bone surgery: current clinical standing. *Exp. Rev. Med. Devices* 1, 229-240.
- Witzke DR et al. (1997). Reversible Kinetics and Thermodynamics of the Homopolymerization of L-Lactide with 2-Ethylhexanoic Acid Tin(II) Salt. *Macromol.*; 30: 7075-7085.
- Yamane H and Sasai K (2003). Effect of the addition of poly(D-lactic acid) on the thermal property of poly(L-lactic acid). *Polymer*; 44: 2569-2575.
- Yang F et al. (2004). Fabrication of nano-structured porous PLLA scaffold intended for nerve tissue engineering. *Biomater.*; 25: 1891-1900.
- Yu Y et al. (2009). Ring-Opening Polymerization of L,L-Lactide: Kinetic and Modeling Study. *Macromol.*; 42: 8187-819.
- Zhang X et al (1994). Mechanism of lactide polymerization in the presence of stannous octoate: The effect of hydroxy and carboxylic acid substances. *J. Polym. Sci. Part A: Polym. Chem.*; 32: 2965-2970.

3.3 Conclusões

Como pode ser observada, a síntese de polímeros degradáveis e absorvíveis a partir de fontes renováveis para aplicações em dispositivos biomédicos tem atraído grande atenção de centros de pesquisas e de setores industriais.

O ácido láctico é um produto de grande importância industrial para a produção de diversas substâncias químicas e especialmente serve como monômero na síntese de PLA. Este ácido pode ser produzido a partir de fermentação da sacarose contida no melão da cana-de-açúcar, o qual é um subproduto da indústria sucroalcooleira, ou melão obtido a partir do bagaço da cana, considerado um co-produto disponível em abundância no Brasil.

O PLA é um polímero sintético amplamente conhecido e um dos polímeros biocompatíveis mais promissores utilizados em diversas aplicações biomédicas, devido a sua degradabilidade e absorbilidade pelo corpo humano. A diversificação de aplicações de PLA é tal que, um único polímero pode ser útil em muitas aplicações, por meio de simples modificações de sua estrutura físico-química e pela propriedade quiral da molécula de ácido láctico, que possui dois centros assimétricos existentes em quatro formas diferentes.

Capítulo 4- Modelagem do Processo

4.1. Introdução

Para simular um processo é importante conhecê-lo e entendê-lo, e a ferramenta mais fácil para fazer aquilo é por meio da modelagem deste. Os processos de síntese do PLA no sistema contínuo e em batelada são modelados neste capítulo utilizando os balanços mássicos de cada componente do sistema para as três etapas do mecanismo de polimerização por abertura de anéis (oligomerização, formação de lactídeo e polimerização).

Foi escolhido o modelo de polimerização *step growth* do *Polymer Plus*, o qual é utilizado para poliésteres como o PLA. Além disso, são definidos os componentes e são feitos os balanços de massa de cada um deles utilizando dados cinéticos que servem para calcular as constantes cinéticas das reações usadas nas simulações no ASPEN PLUS[®], estes dados foram obtidos de Seavey e Liu, 2008.

4.2. Desenvolvimento

4.2.1. Dados cinéticos do processo de síntese do PLA

Os componentes do sistema de síntese de poli (ácido láctico), desenvolvido no *Polymer Plus* (ASPEN PLUS[®]), pela abertura de anéis são apresentados na Tabela 1.

Tabela 1. Componentes do sistema.

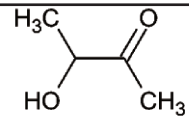
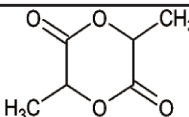
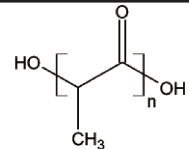
NOME DE COMPONENTE	TIPO	FÓRMULA	ESTRUTURA MOLECULAR
Água - H ₂ O - W	Convencional	H ₂ O	H ₂ O
Ácido Láctico – AL	Convencional	C ₃ H ₆ O ₃	
Lactídeo – C ₂	Convencional	C ₆ H ₁₀ O ₅	
Poli (Ácido Láctico) – PLA	Polímero	C ₃ H ₄ O ₂	
Óxido de Estanho	Convencional	SnO	SnO

Todos os componentes do sistema de polimerização são convencionais, com exceção do PLA. Este é do tipo polímero, ou seja, para o *software* não se comporta como um componente normal. Os polímeros no Aspen Polymers estão conformados por segmentos de compostos (segmentos terminais e repetitivos). O processo de produção de PLA para atingir uma massa molar alta é realizado pela abertura de anéis do lactídeo (dímero do ácido láctico). O mecanismo de polimerização do PLA é descrito nas seguintes equações. As reações (1–3) modelam a etapa de oligomerização.



Estas equações representam reações de esterificação, as quais produzem moléculas de polímero de baixa massa molar. Igualmente representam as reações de hidrólise ou reações reversíveis. (Seavey e Liu, 2008). AL representa o monômero (ácido láctico), W a água, P_2 o dímero linear e, P_n e P_m cadeias lineares curtas de polímero de n e m moléculas de monômero, respectivamente.

Os dois grupos finais dos dímeros lineares podem reagir entre si formando estruturas cíclicas em forma de anéis fechados, na presença do catalisador de óxido de estanho (Seavey e Liu, 2008). Devido à alta estabilidade da molécula cíclica (lactídeo), esta reação é especialmente favorecida sobre a reação inversa (formação de dímeros lineares). A reação (4) representa a síntese do lactídeo e a reação reversível (hidrólise) desta.



Nesta equação, P_2 representa o dímero linear, C_2 o dímero cíclico e W a água. A parte final do processo de síntese do PLA, ou seja, a polimerização do lactídeo, é descrita pelas equações (5) e (6), apresentadas a seguir:



Nesta equação, P_n representa as cadeias lineares de n moléculas do monômero, C_2 o dímero cíclico, AL o ácido láctico, P_3 uma cadeia de três moléculas de ácido láctico e P_{n+2} as cadeias longas de $n+2$ moléculas do monômero (polímero). Na polimerização do lactídeo, devido às pequenas quantidades de ácido láctico e de água, é favorecida a formação de cadeias longas do polímero tendo estas, maior dificuldade de serem rompidas (Seavey e Liu, 2008).

Segundo o manual do curso, *Process Simulation with Polymers Plus* (2004), no simulador é empregado o modelo de *step-growth* para representar a polimerização deste tipo de polímeros. Este modelo utilizado no software gera uma série de reações baseadas nos grupos funcionais especificados pelo usuário. Desta forma, o usuário do simulador é limitado à definição das estruturas dos reagentes em termos de grupos funcionais eletrofílicos e nucleofílicos, visando escolher o tipo de reações a serem geradas pelo modelo, o qual permite encontrar todas as possíveis rotas nas quais as espécies podem reagir. Este modelo gera reações diretas e reversíveis (reações de esterificação e de hidrólise), bem como subseqüentes reações de rearranjo (polimerização) (Seavey e Liu, 2008; *Process Simulation with Polymers Plus*, 2004).

Polymers Plus contém uma ampla base de dados de componentes e de segmentos destes, visto que o modelo de reação utiliza informação de tipos de segmentos para determinar como as reações de polimerização influenciam as propriedades de polímeros como o número de massa molar e o grau de polimerização (*Process Simulation with Polymers Plus*, 2004). Os tipos de segmentos também são especificados como grupos terminais ou segmentos repetitivos pelo usuário no software. No processo de síntese do PLA, os segmentos a definir são os apresentados na Tabela 2.

Tabela 2. Segmentos dos componentes do sistema.

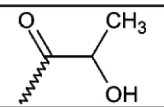
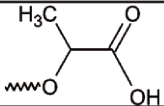
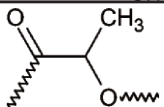
SEGMENTOS	NOME COMUM	FÓRMULA	ESTRUTURA MOLECULAR
AL-D-END	Terminador Alcoólico D-ácido Lático	$C_3H_5O_2$	
AL-L-END	Terminador Carboxílico L-ácido Lático	$C_3H_5O_3$	
AL-R	Segmento Repetitivo	$C_3H_4O_2$	

O usuário insere no *software* a estrutura dos reagentes, produtos e segmentos em termos de espécies ou grupos funcionais nucleofílicos e eletrofílicos (Process Simulation with Polymers Plus, 2004). Na Tabela 3 são definidas as espécies empregadas para a polimerização do ácido láctico. Determinado isto, escolheu-se os tipos de reações a serem geradas a partir do modelo *Step-Growth* de Polymers Plus, que fez os cálculos com os balanços e as propriedades dos componentes em cada etapa do processo de síntese.

Tabela 3. Espécies dos terminais dos componentes do sistema.

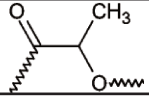
GRUPOS	ÁLCOOL	CARBOXÍLICO	LA-R
ESPÉCIES	-H	-OH	
H ₂ O	1	1	---
AL	1	1	1
AL-L-END	---	1	1
AL-D-END	1	---	1
AL-R	---	---	1
Lactídeo	---	---	2

As reações geradas pelo *software* estão descritas na Tabela 4, que correspondem à primeira etapa do processo de síntese do PLA. Foram geradas doze reações: quatro de polimerização, quatro de condensação e suas respectivas reversíveis. As reações estão baseadas em componentes (monômero, água, lactídeo) e os segmentos deles. As reações que envolvem o lactídeo tanto como reagente, como produto, são especificados de forma separada às outras e são aplicadas na segunda e terceira etapa do processo. Estas últimas reações são apresentadas na Tabela 5.

Tabela 4. Reações geradas pelo software.

REAÇÃO	REAGENTES		PRODUTOS
1) Condensação	AL + AL	→	H ₂ O + AL-L-END + AL-D-END
2) Condensação	AL + AL-L-END	→	H ₂ O + AL-L-END + AL-R
3) Condensação	AL-D-END + AL	→	H ₂ O + AL-R + AL-D-END
4) Condensação	AL-D-END + AL-L-END	→	H ₂ O + AL-R + AL-R
5) Rev-Condensação	H ₂ O + AL-D-END + AL-L-END	→	AL + AL
6) Rev-Condensação	H ₂ O + AL-D-END + AL-R	→	AL + AL-D-END
7) Rev-Condensação	H ₂ O + AL-R + AL-L-END	→	AL-L-END + AL
8) Rev-Condensação	H ₂ O + AL-R + AL-R	→	AL-L-END + AL-D-END
9) Polimerização	AL + AL-D-END + AL-R	→	AL-L-END + AL-D-END + AL-D-END
10) Polimerização	AL + AL-R + AL-R	→	AL-L-END + AL-R + AL-D-END
11) Polimerização	AL-D-END + AL-D-END + AL-L-END	→	AL-R + AL-D-END + AL
12) Polimerização	AL-D-END + AL-R + AL-L-END	→	AL-R + AL-R + AL

Tabela 5. Reações inseridas pelo usuário.

REAÇÃO	REAGENTES		PRODUTOS
13)	Lactídeo	→	2 AL-R
14)	2 AL-R	→	Lactídeo
15)	AL + Lactídeo	→	AL-L-END + AL-R + AL-D-END

O modelo de *Step-Growth* permite agrupar reações e atribuir a estas, um conjunto de constantes de velocidade de reação para um grupo de reações. Para os objetivos desta simulação, foi assumido que os alcoóis e ácidos neste sistema têm a mesma constante de velocidade de reação. Também foi considerado que o grupo ácido no ácido láctico tem a mesma constante de velocidade de reação que o grupo de segmentos terminais do ácido láctico (Seavey e Liu, 2008). A equação utilizada para o cálculo de taxas de reação pelo software é apresentada na equação (7) (Process Simulation with Polymers Plus[®], 2004; Seavey e Liu, 2008).

$$r = [C_{\text{componente}}] P \sum_i [C_i] k_{oi} e^{\frac{-E_a}{R} \left(\frac{1}{T} - \frac{1}{T_{ref}} \right)} \quad (7)$$

Onde $[C_{\text{reagente}}]$ é a concentração de cada reagente ou produto, P é o fator de probabilidade, o qual é calculado pelo modelo internamente e não pode ser tirado da expressão, [C] é a concentração de catalisador, T é a temperatura na qual é operado o reator, T_{ref} é a temperatura de referência, R é a constante universal dos gases, E_a é a energia de ativação e k_o é o fator pré-exponencial.

É necessário inserir na Equação (7), para encontrar as rotas de reação, o fator pré-exponencial, a energia de ativação e a temperatura de referência. Na Tabela 6 são apresentados os dados utilizados para especificar as constantes das velocidades de reação que são específicas para o PLA. Estes dados foram extraídos de Seavey e Liu (2008).

Tabela 6. Dados de velocidades de reação.

No.	ESPÉCIES CATALÍTICAS	k_o [1/min]	E_a [kcal/mol]	T_{ref} [°C]
k_1	Não catalisada	0,02	18	170
k_2	Não catalisada	0,01	18	170
k_3	Catalisador	100	18	170
k_4	Catalisador	50	18	170

São atribuídas às constantes de velocidade k_1 e k_3 , todas as reações que envolvem grupos terminais carboxila (reações de esterificação) e às constantes de velocidade k_2 e k_4 , as reações envolvendo água (reações de hidrólise).

Com o modelo *step-growth* o usuário pode definir as reações adicionais, como as descritas na Tabela 5, a reação de abertura de anéis entre o ácido láctico e lactídeo (reação 3), bem como a inserção de anéis (reação 1) e perda destes (reação 2). As

constantes de velocidade de reação específicas são apresentadas na Tabela 7. Estes dados também foram extraídos de Seavey e Liu (2008).

Tabela 7. Dados de velocidades de reação para reações com lactídeo.

No.	ESPÉCIES CATALÍTICAS	k_o [1/min]	Ea [kcal/mol]	T_{ref} [°C]
k_5	Catalisador	400	18	170
k_6	Catalisador	20	21	170
k_7	Catalisador	400	18	170

4.2.2. Balanços do processo de síntese do PLA em sistema em batelada

Os balanços mássicos de cada componente do sistema de síntese de poli (ácido láctico) desenvolvida com o auxílio do Polymer Plus estão descritos a seguir.

As unidades dos termos dos balanços de massa são:

- $F_{Entrada} \left[\frac{kg_{Total}}{s} \right]$ $x_{Entrada} \left[\frac{kg_{Componente}}{kg_{total}} \right]$

- $F_{Saida} \left[\frac{kg_{Total}}{s} \right]$ $x_{Saida} \left[\frac{kg_{Componente}}{kg_{total}} \right]$

- $r_{H_2O} \left[\frac{kg_{componente}}{m^3 \cdot s} \right]$ $V [m^3]$

- $\rho \left[\frac{kg_{Total}}{m^3} \right]$ $t [s]$

✓ REATOR OLIGOMERIZAÇÃO

No primeiro reator são utilizadas apenas as constantes de velocidade k_1 e k_2 , devido ao fato de que esta reação não é catalisada e não apresenta formação do lactídeo.



Figura 2. Reator de oligomerização em batelada.

• Balanço de H₂O

$$\left(F_{Entrada} \cdot x_{\frac{H_2O}{Entrada}} \right) - \left(F_{Saída} \cdot x_{\frac{H_2O}{Saída}} \right) - r_{\frac{H_2O}{consumido}} \cdot V + r_{\frac{H_2O}{produzido}} \cdot V = \rho \cdot V \cdot \frac{d[x_{\frac{H_2O}}{]}}{dt} \quad (8)$$

$$r_{\frac{H_2O}{consumo}} = (4 \cdot k_2) [x_{\frac{H_2O}{]}} \quad (8.1)$$

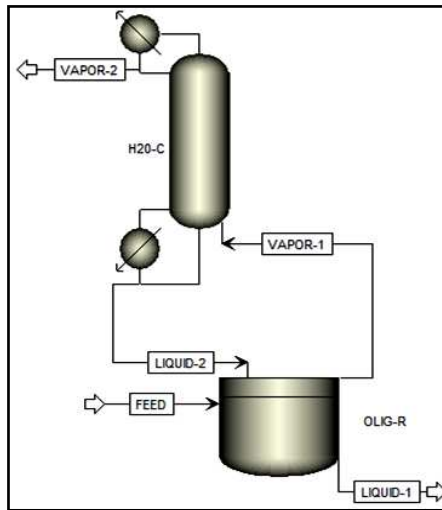
$$r_{\frac{H_2O}{produzido}} = (4 \cdot k_1) [x_{\frac{H_2O}{]}} \quad (8.2)$$

• Balanço de Ácido Láctico

$$\left(F_{Entrada} \cdot x_{\frac{AL}{Entrada}} \right) - \left(F_{Saída} \cdot x_{\frac{AL}{Saída}} \right) - r_{\frac{AL}{consumido}} \cdot V + r_{\frac{AL}{produzido}} \cdot V = \rho \cdot V \cdot \frac{d[x_{\frac{AL}}{]}}{dt} \quad (9)$$

$$\begin{aligned} \text{consumido} \\ r_{AL} &= (4 \cdot k_1) \cdot [x_{AL}] + (k_1)[x_{AL}]^2 \end{aligned} \quad (9.1)$$

$$\begin{aligned} \text{produzido} \\ r_{AL} &= (2 \cdot k_1 + 2 \cdot k_2)[x_{AL}] + (k_2)[x_{AL}]^2 \end{aligned} \quad (9.2)$$

• **Balço de Segmento Terminal L**

$$-\left(F_{Saída} \cdot x_{\frac{AL-L-END}{Saída}} \right) - r_{AL-L-END}^{\text{consumido}} \cdot V + r_{AL-L-END}^{\text{produzido}} \cdot V = \rho \cdot V \cdot \frac{d[x_{AL-L-END}]}{dt} \quad (10)$$

$$\begin{aligned} \text{consumido} \\ r_{AL-L-END} &= (4 \cdot k_1 + 2 \cdot k_2)[x_{AL-L-END}] \end{aligned} \quad (10.1)$$

$$\begin{aligned} \text{produzido} \\ r_{AL-L-END} &= (3 \cdot k_1 + 2 \cdot k_2)[x_{AL-L-END}] + (k_1)[x_{AL-L-END}]^2 \end{aligned} \quad (10.2)$$

• **Balço de Segmento Terminal D**

$$-\left(F_{Saída} \cdot x_{\frac{AL-D-END}{Saída}} \right) - r_{AL-D-END}^{\text{consumido}} \cdot V + r_{AL-D-END}^{\text{produzido}} \cdot V = \rho \cdot V \cdot \frac{d[x_{AL-D-END}]}{dt} \quad (11)$$

$$\begin{aligned} \text{consumido} \\ r_{AL-D-END} &= (3 \cdot k_1 + 2 \cdot k_2)[x_{AL-D-END}] + (k_1)[x_{AL-D-END}]^2 \end{aligned} \quad (11.1)$$

$$\begin{aligned} \text{produzido} \\ r_{AL-D-END} &= (4 \cdot k_1 + 2 \cdot k_2)[x_{AL-D-END}] + (k_1)[x_{AL-D-END}]^2 \end{aligned} \quad (11.2)$$

• **Balço de Segmento Repetitivo**

$$-\left(F_{Saída} \cdot x_{\frac{AL-R}{Saída}} \right) - r_{AL-R}^{\text{consumido}} \cdot V + r_{AL-R}^{\text{produzido}} \cdot V = \rho \cdot V \cdot \frac{d[x_{AL-R}]}{dt} \quad (12)$$

$$\begin{aligned} \text{consumido} \\ r_{AL-R} &= (2 \cdot k_1 + 2 \cdot k_2)[x_{AL-R}] + (k_1 + k_2)[x_{AL-R}]^2 \end{aligned} \quad (12.1)$$

$$\begin{aligned} \text{produzido} \\ r_{AL-R} &= (4 \cdot k_1)[x_{AL-R}] + (2 \cdot k_1)[x_{AL-R}]^2 \end{aligned} \quad (12.2)$$

✓ REATOR DE FORMAÇÃO DE LACTÍDEO

Neste reator, ocorre a síntese do lactídeo na presença do catalisador (óxido de estanho). Deste modo, são utilizadas as constantes de velocidade k_3 e k_4 , para o conjunto de reações geradas pelo *software*. Além disso, a reação de formação do lactídeo e a hidrólise dele estão presentes nesta etapa do processo, sendo necessária a utilização das constantes de velocidade k_5 e k_6 .



Figura 3. Reator de formação de lactídeo em batelada.

• Balanço de H₂O

$$\left(F_{Entrada} \cdot x_{\frac{H_2O}{Entrada}} \right) - \left(F_{Saída} \cdot x_{\frac{H_2O}{Saída}} \right) - r_{\frac{H_2O}{consumido}} \cdot V + r_{\frac{H_2O}{produzido}} \cdot V = \rho \cdot V \cdot \frac{d[x_{H_2O}]}{dt} \quad (13)$$

$$r_{\frac{H_2O}{consumo}} = (4 \cdot k_4) [x_{H_2O}] \quad (13.1)$$

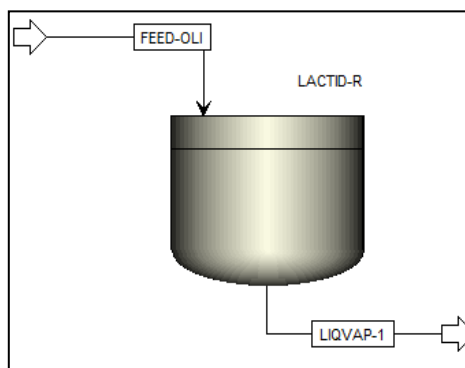
$$r_{\frac{H_2O}{produzido}} = (4 \cdot k_3) [x_{H_2O}] \quad (13.2)$$

• Balanço de Ácido Láctico

$$\left(F_{Entrada} \cdot x_{\frac{AL}{Entrada}} \right) - \left(F_{Saída} \cdot x_{\frac{AL}{Saída}} \right) - r_{\frac{AL}{consumido}} \cdot V + r_{\frac{AL}{produzido}} \cdot V = \rho \cdot V \cdot \frac{d[x_{AL}]}{dt} \quad (14)$$

$$\begin{aligned} \text{consumido} \\ r_{AL} &= (4 \cdot k_3)[x_{AL}] + (k_3)[x_{AL}]^2 \end{aligned} \quad (14.1)$$

$$\begin{aligned} \text{produzido} \\ r_{AL} &= (2 \cdot k_3 + 2 \cdot k_4)[x_{AL}] + (k_4)[x_{AL}]^2 \end{aligned} \quad (14.2)$$

• **Balço de Segmento Terminal L**

$$\begin{aligned} &\left(F_{\text{Entrada}} \cdot x_{\frac{AL-L-END}{\text{Entrada}}} \right) - \left(F_{\text{Saída}} \cdot x_{\frac{AL-L-END}{\text{Saída}}} \right) - r_{AL-L-END}^{\text{consumido}} \cdot V + r_{AL-L-END}^{\text{produzido}} \cdot V = \\ &\rho \cdot V \cdot \frac{d[x_{AL-L-END}]}{dt} \end{aligned} \quad (15)$$

$$\begin{aligned} \text{consumido} \\ r_{AL-L-END} &= (4 \cdot k_3 + 2 \cdot k_4)[x_{AL-L-END}] \end{aligned} \quad (15.1)$$

$$\begin{aligned} \text{produzido} \\ r_{AL-L-END} &= (3 \cdot k_3 + 2 \cdot k_4)[x_{AL-L-END}] + (k_3)[x_{AL-L-END}]^2 \end{aligned} \quad (15.2)$$

• **Balço de Segmento Terminal D**

$$\begin{aligned} &\left(F_{\text{Entrada}} \cdot x_{\frac{AL-D-END}{\text{Entrada}}} \right) - \left(F_{\text{Saída}} \cdot x_{\frac{AL-D-END}{\text{Saída}}} \right) - r_{AL-D-END}^{\text{consumido}} \cdot V + r_{AL-D-END}^{\text{produzido}} \cdot V = \\ &\rho \cdot V \cdot \frac{d[x_{AL-D-END}]}{dt} \end{aligned} \quad (16)$$

$$\begin{aligned} \text{consumido} \\ r_{AL-D-END} &= (3 \cdot k_3 + 2 \cdot k_4)[x_{AL-D-END}] + (k_3)[x_{AL-D-END}]^2 \end{aligned} \quad (16.1)$$

$$\begin{aligned} \text{produzido} \\ r_{AL-D-END} &= (4 \cdot k_3 + 2 \cdot k_4)[x_{AL-D-END}] + (k_3)[x_{AL-D-END}]^2 \end{aligned} \quad (16.2)$$

• **Balço de Segmento Repetitivo**

* *Modelagem e simulação do processo de produção de PLA (poli-ácido láctico) obtido a partir de fontes renováveis para uso biomédico* *

$$\left(F_{\text{Entrada}} \cdot x_{\frac{AL-R}{\text{Entrada}}} \right) - \left(F_{\text{Saida}} \cdot x_{\frac{AL-R}{\text{Saida}}} \right) - r_{\text{AL-R}}^{\text{consumido}} \cdot V + r_{\text{AL-R}}^{\text{produzido}} \cdot V = \rho \cdot V \cdot \frac{d[x_{\frac{AL-R}}{}}{dt} \quad (17)$$

$$r_{\text{AL-R}}^{\text{consumido}} = (2 \cdot k_3 + 2 \cdot k_4)[x_{\text{AL-R}}] + (k_3 + k_4 + k_6)[x_{\text{AL-R}}]^2 \quad (17.1)$$

$$r_{\text{AL-R}}^{\text{produzido}} = (4 \cdot k_3)[x_{\text{AL-R}}] + (2 \cdot k_3 + k_5)[x_{\text{AL-R}}]^2 \quad (17.2)$$

- **Balço de Lactídeo**

$$- \left(F_{\text{Saida}} \cdot x_{\frac{\text{Lactídeo}}{\text{Saida}}} \right) - r_{\text{Lactídeo}}^{\text{consumido}} \cdot V + r_{\text{Lactídeo}}^{\text{produzido}} \cdot V = \rho \cdot V \cdot \frac{d[x_{\text{Lactídeo}}]}{dt} \quad (18)$$

$$r_{\text{Lactídeo}}^{\text{consumido}} = (k_5)[x_{\text{Lactídeo}}] \quad (18.1)$$

$$r_{\text{Lactídeo}}^{\text{produzido}} = (k_6)[x_{\text{Lactídeo}}] \quad (18.2)$$

- ✓ **REATOR DE POLIMERIZAÇÃO**

Na última etapa do processo de síntese do PLA, reator de polimerização, a reação também é realizada na presença do catalisador, utilizando as constantes de velocidade k_3 e k_4 , para o conjunto de reações geradas pelo *software*. As demais constantes de velocidade, k_5 , k_6 e k_7 , são utilizadas para as reações que envolvem o lactídeo, incluindo a adição de anéis.



Figura 4. Reator de polimerização em batelada.

• **Balço de H₂O**

$$\left(F_{Entrada} \cdot x_{\frac{H_2O}{Entrada}} \right) - \left(F_{Saída} \cdot x_{\frac{H_2O}{Saída}} \right) - r_{H_2O}^{consumido} \cdot V + r_{H_2O}^{produzido} \cdot V = \rho \cdot V \cdot \frac{d[x_{H_2O}]}{dt} \quad (19)$$

$$\begin{matrix} \text{consumo} \\ r_{H_2O} \end{matrix} = (4 \cdot k_4)[x_{H_2O}] \quad (19.1)$$

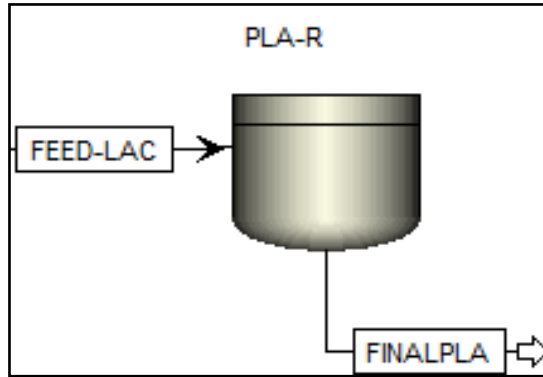
$$\begin{matrix} \text{produzido} \\ r_{H_2O} \end{matrix} = (4 \cdot k_3)[x_{H_2O}] \quad (19.2)$$

• **Balço de Ácido Láctico**

$$\left(F_{Entrada} \cdot x_{\frac{AL}{Entrada}} \right) - \left(F_{Saída} \cdot x_{\frac{AL}{Saída}} \right) - r_{AL}^{consumido} \cdot V + r_{AL}^{produzido} \cdot V = \rho \cdot V \cdot \frac{d[x_{AL}]}{dt} \quad (20)$$

$$\begin{matrix} \text{consumido} \\ r_{AL} \end{matrix} = (4 \cdot k_3 + k_7)[x_{AL}] + (k_3)[x_{AL}]^2 \quad (20.1)$$

$$\begin{matrix} \text{produzido} \\ r_{AL} \end{matrix} = (2 \cdot k_3 + 2 \cdot k_4)[x_{AL}] + (k_4)[x_{AL}]^2 \quad (20.2)$$

• **Balço de Segmento Terminal L**

* Modelagem e simulação do processo de produção de PLA (poli-ácido láctico) obtido a partir de fontes renováveis para uso biomédico *

$$\left(F_{\text{Entrada}} \cdot x_{\frac{AL-L-END}{\text{Entrada}}} \right) - \left(F_{\text{Saída}} \cdot x_{\frac{AL-L-END}{\text{Saída}}} \right) - r_{\frac{AL-L-END}{\text{consumido}}} \cdot V + r_{\frac{AL-L-END}{\text{produzido}}} \cdot V = \rho \cdot V \cdot \frac{d[x_{\frac{AL-L-END}{\text{Entrada}}}]}{dt} \quad (21)$$

$$r_{\frac{AL-L-END}{\text{consumido}}} = (4 \cdot k_3 + 2 \cdot k_4) [x_{\frac{AL-L-END}{\text{Entrada}}}] \quad (21.1)$$

$$r_{\frac{AL-L-END}{\text{produzido}}} = (3 \cdot k_3 + 2 \cdot k_4 + k_7) [x_{\frac{AL-L-END}{\text{Entrada}}}] + (k_3) [x_{\frac{AL-L-END}{\text{Entrada}}}]^2 \quad (21.2)$$

• **Balço de Segmento Terminal D**

$$\left(F_{\text{Entrada}} \cdot x_{\frac{AL-D-END}{\text{Entrada}}} \right) - \left(F_{\text{Saída}} \cdot x_{\frac{AL-D-END}{\text{Saída}}} \right) - r_{\frac{AL-D-END}{\text{consumido}}} \cdot V + r_{\frac{AL-D-END}{\text{produzido}}} \cdot V = \rho \cdot V \cdot \frac{d[x_{\frac{AL-D-END}{\text{Entrada}}}]}{dt} \quad (22)$$

$$r_{\frac{AL-D-END}{\text{consumido}}} = (3 \cdot k_3 + 2 \cdot k_4) [x_{\frac{AL-D-END}{\text{Entrada}}}] + (k_3) [x_{\frac{AL-D-END}{\text{Entrada}}}]^2 \quad (22.1)$$

$$r_{\frac{AL-D-END}{\text{produzido}}} = (4 \cdot k_3 + 2 \cdot k_4 + k_7) [x_{\frac{AL-D-END}{\text{Entrada}}}] + (k_3) [x_{\frac{AL-D-END}{\text{Entrada}}}]^2 \quad (22.2)$$

• **Balço de Segmento Repetitivo**

$$\left(F_{\text{Entrada}} \cdot x_{\frac{AL-R}{\text{Entrada}}} \right) - \left(F_{\text{Saída}} \cdot x_{\frac{AL-R}{\text{Saída}}} \right) - r_{\frac{AL-R}{\text{consumido}}} \cdot V + r_{\frac{AL-R}{\text{produzido}}} \cdot V = \rho \cdot V \cdot \frac{d[x_{\frac{AL-R}{\text{Entrada}}}]}{dt} \quad (23)$$

$$r_{\frac{AL-R}{\text{consumido}}} = (2 \cdot k_3 + 2 \cdot k_4) [x_{\frac{AL-R}{\text{Entrada}}}] + (k_3 + k_4 + k_6) [x_{\frac{AL-R}{\text{Entrada}}}]^2 \quad (23.1)$$

$$r_{AL-R}^{produzido} = (4 \cdot k_3 + k_7)[x_{AL-R}] + (2 \cdot k_3 + k_5)[x_{AL-R}]^2 \quad (23.2)$$

- **Balanço de Lactídeo**

$$\left(F_{Entrada} \cdot x_{\frac{Lactídeo}{Entrada}} \right) - \left(F_{Saída} \cdot x_{\frac{Lactídeo}{Saída}} \right) - r_{Lactídeo}^{consumido} \cdot V + r_{Lactídeo}^{produzido} \cdot V = \rho \cdot V \cdot \frac{d[x_{Lactídeo}]}{dt} \quad (24)$$

$$r_{Lactídeo}^{consumido} = (k_5 + k_7)[x_{Lactídeo}] \quad (24.1)$$

$$r_{Lactídeo}^{produzido} = (k_6)[x_{Lactídeo}] \quad (24.2)$$

4.2.3. Balanços do processo de síntese do PLA em sistema contínuo

A síntese de poli (ácido láctico) foi desenvolvida com o auxílio do programa Polymer Plus. Os balanços mássicos de cada componente, para cada um dos reatores CSTR simulados, são apresentados a seguir. Os balanços mássicos são os mesmos que os descritos para o sistema em batelada, exceto que estes não apresentam o termo de variação no tempo, ou seja, estes termos estão igualados a zero.

- ✓ **REATOR OLIGOMERIZAÇÃO**

Neste reator, apresentado na Figura 5, a exemplo do que ocorre no reator de oligomerização do sistema de reatores contínuos, são utilizadas as constantes de velocidade k_1 e k_2 descritas no início do capítulo.



Figura 5. Reator CSTR de oligomerização.

- **Balço de H₂O**

$$\left(F_{Entrada} \cdot x_{\frac{H_2O}{Entrada}} \right) - \left(F_{Saída} \cdot x_{\frac{H_2O}{Saída}} \right) - r_{\frac{H_2O}{consumido}} \cdot V + r_{\frac{H_2O}{produzido}} \cdot V = 0 \quad (25)$$

$$\begin{matrix} \text{consumo} \\ r_{H_2O} \end{matrix} = (4 \cdot k_2)[x_{H_2O}] \quad (25.1)$$

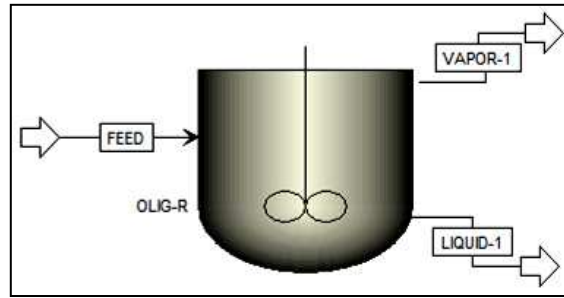
$$\begin{matrix} \text{produzido} \\ r_{H_2O} \end{matrix} = (4 \cdot k_1)[x_{H_2O}] \quad (25.2)$$

- **Balço de Ácido Láctico**

$$\left(F_{Entrada} \cdot x_{\frac{AL}{Entrada}} \right) - \left(F_{Saída} \cdot x_{\frac{AL}{Saída}} \right) - r_{\frac{AL}{consumido}} \cdot V + r_{\frac{AL}{produzido}} \cdot V = 0 \quad (26)$$

$$\begin{matrix} \text{consumido} \\ r_{AL} \end{matrix} = (4 \cdot k_1) \cdot [x_{AL}] + (k_1)[x_{AL}]^2 \quad (26.1)$$

$$\begin{matrix} \text{produzido} \\ r_{AL} \end{matrix} = (2 \cdot k_1 + 2 \cdot k_2)[x_{AL}] + (k_2)[x_{AL}]^2 \quad (26.2)$$

- **Balço de Segmento Terminal L**

$$- \left(F_{Saída} \cdot x_{\frac{AL-L-END}{Saída}} \right) - r_{\frac{AL-L-END}{consumido}} \cdot V + r_{\frac{AL-L-END}{produzido}} \cdot V = 0 \quad (27)$$

$$r_{AL-L-END}^{consumido} = (4 \cdot k_1 + 2 \cdot k_2)[x_{AL-L-END}] \quad (27.1)$$

$$r_{AL-L-END}^{produzido} = (3 \cdot k_1 + 2 \cdot k_2)[x_{AL-L-END}] + (k_1)[x_{AL-L-END}]^2 \quad (27.2)$$

• **Balanco de Segmento Terminal D**

$$-\left(F_{Saída} \cdot x_{\frac{AL-D-END}{Saída}} \right) - r_{AL-D-END}^{consumido} \cdot V + r_{AL-D-END}^{produzido} \cdot V = 0 \quad (28)$$

$$r_{AL-D-END}^{consumido} = (3 \cdot k_1 + 2 \cdot k_2)[x_{AL-D-END}] + (k_1)[x_{AL-D-END}]^2 \quad (28.1)$$

$$r_{AL-D-END}^{produzido} = (4 \cdot k_1 + 2 \cdot k_2)[x_{AL-D-END}] + (k_1)[x_{AL-D-END}]^2 \quad (28.2)$$

• **Balanco de Segmento Repetitivo**

$$-\left(F_{Saída} \cdot x_{\frac{AL-R}{Saída}} \right) - r_{AL-R}^{consumido} \cdot V + r_{AL-R}^{produzido} \cdot V = 0 \quad (29)$$

$$r_{AL-R}^{consumido} = (2 \cdot k_1 + 2 \cdot k_2)[x_{AL-R}] + (k_1 + k_2)[x_{AL-R}]^2 \quad (29.1)$$

$$r_{AL-R}^{produzido} = (4 \cdot k_1)[x_{AL-R}] + (2 \cdot k_1)[x_{AL-R}]^2 \quad (29.2)$$

✓ **REATOR DE FORMAÇÃO DE LACTÍDEO**

Na produção de lactídeo, que ocorre no reator CSTR apresentado na Figura 6, são utilizadas as constantes de velocidade k_3 , k_4 , k_5 e k_6 .



Figura 6. Reator CSTR de formação de lactídeo.

• **Balço de H₂O**

$$\left(F_{Entrada} \cdot x_{\frac{H_2O}{Entrada}} \right) - \left(F_{Saída} \cdot x_{\frac{H_2O}{Saída}} \right) - r_{H_2O}^{consumido} \cdot V + r_{H_2O}^{produzido} \cdot V = 0 \quad (30)$$

$$r_{H_2O}^{consumo} = (4 \cdot k_4) [x_{H_2O}] \quad (30.1)$$

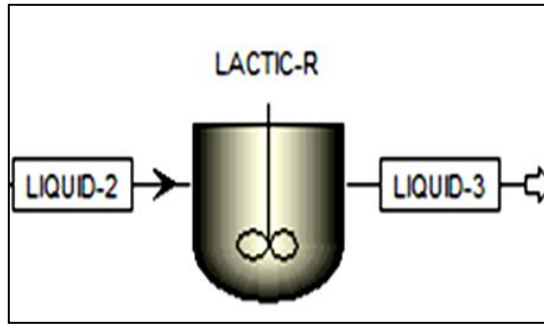
$$r_{H_2O}^{produzido} = (4 \cdot k_3) [x_{H_2O}] \quad (30.2)$$

• **Balço de Ácido Láctico**

$$\left(F_{Entrada} \cdot x_{\frac{AL}{Entrada}} \right) - \left(F_{Saída} \cdot x_{\frac{AL}{Saída}} \right) - r_{AL}^{consumido} \cdot V + r_{AL}^{produzido} \cdot V = 0 \quad (31)$$

$$r_{AL}^{consumido} = (4 \cdot k_3) [x_{AL}] + (k_3) [x_{AL}]^2 \quad (31.1)$$

$$r_{AL}^{produzido} = (2 \cdot k_3 + 2 \cdot k_4) [x_{AL}] + (k_4) [x_{AL}]^2 \quad (31.2)$$

• **Balço de Segmento Terminal L**

$$\left(F_{Entrada} \cdot x_{\frac{AL-L-END}{Entrada}} \right) - \left(F_{Saída} \cdot x_{\frac{AL-L-END}{Saída}} \right) - r_{AL-L-END}^{consumido} \cdot V + r_{AL-L-END}^{produzido} \cdot V = 0 \quad (32)$$

$$r_{AL-L-END}^{consumido} = (4 \cdot k_3 + 2 \cdot k_4)[x_{AL-L-END}] \quad (32.1)$$

$$r_{AL-L-END}^{produzido} = (3 \cdot k_3 + 2 \cdot k_4)[x_{AL-L-END}] + (k_3)[x_{AL-L-END}]^2 \quad (32.2)$$

• **Balanzo de Segmento Terminal D**

$$\left(F_{Entrada} \cdot x_{\frac{AL-D-END}{Entrada}} \right) - \left(F_{Saida} \cdot x_{\frac{AL-D-END}{Saida}} \right) - r_{AL-D-END}^{consumido} \cdot V + r_{AL-D-END}^{produzido} \cdot V = 0 \quad (33)$$

$$r_{AL-D-END}^{consumido} = (3 \cdot k_3 + 2 \cdot k_4)[x_{AL-D-END}] + (k_3)[x_{AL-D-END}]^2 \quad (33.1)$$

$$r_{AL-D-END}^{produzido} = (4 \cdot k_3 + 2 \cdot k_4)[x_{AL-D-END}] + (k_3)[x_{AL-D-END}]^2 \quad (33.2)$$

• **Balanzo de Segmento Repetitivo**

$$\left(F_{Entrada} \cdot x_{\frac{AL-R}{Entrada}} \right) - \left(F_{Saida} \cdot x_{\frac{AL-R}{Saida}} \right) - r_{AL-R}^{consumido} \cdot V + r_{AL-R}^{produzido} \cdot V = 0 \quad (34)$$

$$r_{AL-R}^{consumido} = (2 \cdot k_3 + 2 \cdot k_4)[x_{AL-R}] + (k_3 + k_4 + k_6)[x_{AL-R}]^2 \quad (34.1)$$

$$r_{AL-R}^{produzido} = (4 \cdot k_3)[x_{AL-R}] + (2 \cdot k_3 + k_5)[x_{AL-R}]^2 \quad (34.2)$$

• **Balanzo de Lactídeo**

$$- \left(F_{Saida} \cdot x_{\frac{Lactídeo}{Saida}} \right) - r_{Lactídeo}^{consumido} \cdot V + r_{Lactídeo}^{produzido} \cdot V = 0 \quad (35)$$

$$r_{Lactídeo}^{consumido} = (k_5)[x_{Lactídeo}] \quad (35.1)$$

$$r_{Lactídeo}^{produzido} = (k_6)[x_{Lactídeo}] \quad (35.2)$$

✓ REATOR DE POLIMERIZAÇÃO

Na produção de PLA de elevada massa molar, são utilizadas as constantes de velocidade k_3 , k_4 , k_5 , k_6 e k_7 . O reator onde a produção de PLA ocorre é apresentado na Figura 7.



Figura 7. Reator CSTR de polimerização.

• Balanço de H₂O

$$\left(F_{\text{Entrada}} \cdot x_{\frac{H_2O}{\text{Entrada}}} \right) - \left(F_{\text{Saída}} \cdot x_{\frac{H_2O}{\text{Saída}}} \right) - r_{\frac{H_2O}{\text{consumido}}} \cdot V + r_{\frac{H_2O}{\text{produzido}}} \cdot V = 0 \quad (36)$$

$$r_{\frac{H_2O}{\text{consumo}}} = (4 \cdot k_4) [x_{\frac{H_2O}{\text{consumo}}}] \quad (36.1)$$

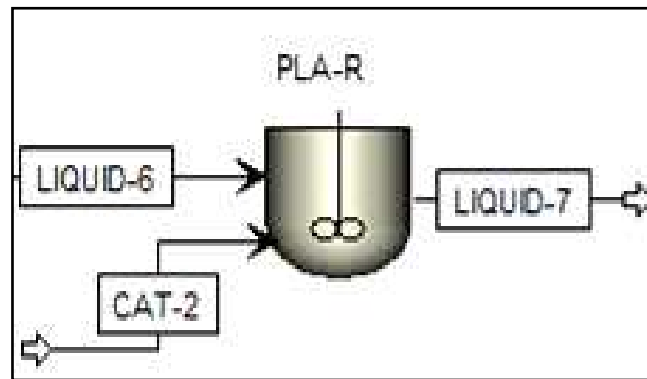
$$r_{\frac{H_2O}{\text{produzido}}} = (4 \cdot k_3) [x_{\frac{H_2O}{\text{produzido}}}] \quad (36.2)$$

• Balanço de Ácido Láctico

$$\left(F_{\text{Entrada}} \cdot x_{\frac{AL}{\text{Entrada}}} \right) - \left(F_{\text{Saída}} \cdot x_{\frac{AL}{\text{Saída}}} \right) - r_{\frac{AL}{\text{consumido}}} \cdot V + r_{\frac{AL}{\text{produzido}}} \cdot V = 0 \quad (37)$$

$$\begin{matrix} \text{consumido} \\ r_{AL} \end{matrix} = (4 \cdot k_3 + k_7)[x_{AL}] + (k_3)[x_{AL}]^2 \quad (37.1)$$

$$\begin{matrix} \text{produzido} \\ r_{AL} \end{matrix} = (2 \cdot k_3 + 2 \cdot k_4)[x_{AL}] + (k_4)[x_{AL}]^2 \quad (37.2)$$

• **Balanzo de Segmento Terminal L**

$$\left(F_{\text{Entrada}} \cdot x_{\frac{AL-L-END}{\text{Entrada}}} \right) - \left(F_{\text{Saída}} \cdot x_{\frac{AL-L-END}{\text{Saída}}} \right) - r_{AL-L-END}^{\text{consumido}} \cdot V + r_{AL-L-END}^{\text{produzido}} \cdot V = 0 \quad (38)$$

$$\begin{matrix} \text{consumido} \\ r_{AL-L-END} \end{matrix} = (4 \cdot k_3 + 2 \cdot k_4)[x_{AL-L-END}] \quad (38.1)$$

$$\begin{matrix} \text{produzido} \\ r_{AL-L-END} \end{matrix} = (3 \cdot k_3 + 2 \cdot k_4 + k_7)[x_{AL-L-END}] + (k_3)[x_{AL-L-END}]^2 \quad (38.2)$$

• **Balanzo de Segmento Terminal D**

$$\left(F_{\text{Entrada}} \cdot x_{\frac{AL-D-END}{\text{Entrada}}} \right) - \left(F_{\text{Saída}} \cdot x_{\frac{AL-D-END}{\text{Saída}}} \right) - r_{AL-D-END}^{\text{consumido}} \cdot V + r_{AL-D-END}^{\text{produzido}} \cdot V = 0 \quad (39)$$

$$\begin{matrix} \text{consumido} \\ r_{AL-D-END} \end{matrix} = (3 \cdot k_3 + 2 \cdot k_4)[x_{AL-D-END}] + (k_3)[x_{AL-D-END}]^2 \quad (39.1)$$

$$\begin{matrix} \text{produzido} \\ r_{AL-D-END} \end{matrix} = (4 \cdot k_3 + 2 \cdot k_4 + k_7)[x_{AL-D-END}] + (k_3)[x_{AL-D-END}]^2 \quad (39.2)$$

• **Balanzo de Segmento Repetitivo**

$$\left(F_{\text{Entrada}} \cdot x_{\frac{AL-R}{\text{Entrada}}} \right) - \left(F_{\text{Saída}} \cdot x_{\frac{AL-R}{\text{Saída}}} \right) - r_{AL-R}^{\text{consumido}} \cdot V + r_{AL-R}^{\text{produzido}} \cdot V = 0 \quad (40)$$

$$\begin{matrix} \text{consumido} \\ r_{AL-R} \end{matrix} = (2 \cdot k_3 + 2 \cdot k_4)[x_{AL-R}] + (k_3 + k_4 + k_6)[x_{AL-R}]^2 \quad (40.1)$$

• *Modelagem e simulação do processo de produção de PLA (poli-ácido láctico) obtido a partir de fontes renováveis para uso biomédico* •

$$r_{AL-R}^{produzido} = (4 \cdot k_3 + k_7)[x_{AL-R}] + (2 \cdot k_3 + k_5)[x_{AL-R}]^2 \quad (40.2)$$

• **Balço de Lactídeo**

$$\left(F_{Entrada} \cdot x_{\frac{Lactídeo}{Entrada}} \right) - \left(F_{Saída} \cdot x_{\frac{Lactídeo}{Saída}} \right) - r_{Lactídeo}^{consumido} \cdot V + r_{Lactídeo}^{produzido} \cdot V = 0 \quad (41)$$

$$r_{Lactídeo}^{consumido} = (k_5 + k_7)[x_{Lactídeo}] \quad (41.1)$$

$$r_{Lactídeo}^{produzido} = (k_6)[x_{Lactídeo}] \quad (41.2)$$

4.3. Conclusões

As modelagens dos sistemas de polimerização, contínuo e batelada, se diferenciaram no termo de acúmulo de cada balanço mássico dos componentes, já que no sistema em batelada este é representado pela variação da composição do componente analisado no tempo, e no sistema em batelada este termo é zero, porque nos reatores CSTR as composições dos componentes não mudam com o tempo.

As velocidades ou taxas de reação para consumo e produção de componentes foram definidas como variáveis que dependem das constantes cinéticas e as composições dos mesmos componentes. As constantes cinéticas foram calculadas com dados obtidos na literatura (Seavey e Liu, 2008).

As reações utilizadas durante o processo de polimerização do PLA foram definidas usando os segmentos do PLA (AL-L-END, AL-D-END, AL-R).

Capítulo 5- Sistema Contínuo

5.1 Introdução

O PLA e seus copolímeros são bastante utilizados na área médica, tanto na produção de implantes como em outros dispositivos, devido a seu excelente desempenho de biocompatibilidade e degradabilidade (Auras *et al.*, 2004; Wang *et al.*, 1999). Trata-se de um polímero muito versátil, que pode ser produzido com uma ampla gama de propriedades. Experimentalmente é difícil, caro e demorado encontrar os melhores valores ou os valores ótimos de muitas variáveis para atingir propriedades requeridas ou desejadas de um material (Seavey e Liu, 2008).

Feitas estas considerações, este Capítulo tem como objetivo principal simular o processo de síntese do PLA a partir do ácido láctico obtido de um processo de fermentação através do simulador comercial (ASPEN PLUS®). São identificadas as relações das propriedades do polímero com as condições operacionais, visando obter um produto final com as características desejadas (massa molar). Os perfis das variáveis operacionais de cada estágio da polimerização do PLA por abertura de anéis são apresentados no Anexo A.

5.2 Desenvolvimento

O desenvolvimento deste capítulo é apresentado a seguir, no artigo intitulado “*A Computer Tool for the Development of Poly (Lactic Acid) Synthesis Process from Renewable Feedstock for Biomanufacturing*”, publicado nos anais do XXI *European Symposium on Computer Aided Process Engineering* e na revista *Computer Aided Chemical Engineering*, volume 29, 2011, Páginas 346-350.

A computer tool for the development of poly (lactic acid) synthesis process from renewable feedstock for biomanufacturing

Guillermo A. R. Martinez^{a,b}, Astrid J. R. Lasprilla^{a,b}, Betânia H. Lunelli^{a,b},
André L. Jardim^{a,b}, Rubens Maciel Filho^{a,b}

^aLaboratory of Optimization, Design and Advanced Control(LOPCA), School of Chemical Engineering, State University of Campinas (UNICAMP), Campinas (SP) 13083-852, Brazil

^bInstitute of Biofabrication, State University of Campinas (UNICAMP), Campinas (SP) 13083-852, Brazil

Abstract

The advances in medicine and engineering to treat loss or bad function of organs or tissues have motivated the development of biomaterials and techniques for biomanufacturing to improve life quality. Among this biomaterials (biopolymers), the poly (lactic acid) (PLA) has received significant attention. PLA is produced from lactic acid, a product that can be obtained by fermentation of sugars from renewable sources such as sugarcane and corn. PLA is thermoplastic and high strength material, and it is degraded in the body by simple hydrolysis of the ester at a rate that can be controlled. PLA and its copolymers are being used in medical field in the form of implants or devices due to its excellent biocompatibility and biodegradability. PLA is a versatile polymer which can be produced with a wide spectrum of properties. It is extremely difficult to, experimentally, find out the optimal values of the many variables to achieve the require properties, since it is time consuming and expensive. Bearing this in mind, this work aims to simulate the PLA synthesis process from renewable feedstock in commercial simulator software (ASPEN PLUS[®]) identifying the polymer properties relation with operational conditions to obtain a final product with characteristics desired.

Keywords: biodegradable polymer; biomedical devices; simulation; kinetics polymerization.

1. Introduction

Tissue engineering is one of the most important areas of material science, in which multidisciplinary scientists are contributing to human health care producing tissue substitutes that can restore the structural features and physiological functions of natural tissues in vivo. Metallic and ceramic implants was the most used for medical purposes, but these conventional “durable” materials have been conceptually challenged by recent advances in developing of biopolymers (natural and sintetic), based on renewable resources. Biodegradable and bioabsorbable polymers are capable of accommodating cell-drive tissue formation and undergo degradation; thereby preventing the patient undergoes a second surgery to remove the device, reducing cost and trauma. Poly (lactic acid) (PLA) or polylactide stands out among the emerging bioplastics market with the best availability, property profile and the most attractive cost structure.

PLA can be produced by condensation polymerization directly from lactic acid, which is derived by fermentation of sugars from carbohydrate sources. Most commercial routes, however, utilize the more efficient conversion of lactide—the cyclic dimer of lactic acid—to PLA via ring-opening polymerization (ROP) catalyzed by a Sn(II)-based catalyst rather than polycondensation. Because the presence of two isomers in the lactic acid, the stereochemistry structure of the PLA can be easily modified by polymerization of a controlled mixture of L (+) or D (-) isomers from the monomer. Efficient purification

technologies that lead to high yield and purity for the key intermediate (lactide) are very important for the process. PLA is a highly versatile biodegradable polymer which can be tailor-made into different resin grades for processing into a wide spectrum of products. More importantly, the polymer can be processed using the conventional production infrastructure with minimal equipment modification.

It is difficult and expensive, beyond too time consuming, to obtain experimentally a material with the properties required for an application looking for the optimal values of the many variables. A suitable way to do that is through mathematical modelling and simulation process to evaluate the impact of process variables on the polymer properties in order to determine the experimental conditions to obtain high yield and predicting final characteristics of the desired product, such as, molecular weight distributions and monomer conversion. The aim of this study is to reproduce the PLA synthesis process from renewable feedstock in commercial simulator. PLA process kinetic parameters were experimentally determined for lactic acid synthesized from fermentation of sucrose. Simulations carried on Aspen Plus allow identifying how the polymer properties are related to the operational conditions. It is shown how is possible to identify the best operational conditions for each particular polymer properties depending upon specific application. The developed simulation procedure is a suitable tool to guide in the production of tailor made PLA polymers for biomanufacturing.

2. Metodology

The PLA synthesis process was divided in two principal sections, to know: in the first in which was carried out the simulation of the lactic acid fermentation process; secondly, the PLA synthesis simulation, through the purified lactic acid, obtained from the process of lactic acid production.

2.1. Lactic Acid Synthesis by Fermentation

Lactic acid is an important product for the biorenewable economy because of its bifunctionality and may be converted, through a variety of reactions, in different value-added products. Polymers based on lactic acid are a most promising category of polymers made from renewable feedstock. Lactic acid was produced in a discontinuous process in bench scale from sucrose by *Lactobacillus plantarum*. It is a versatile bacterium, facultative heterofermentative i.e. has two active metabolic pathways and it is able to produce both isomers of lactic acid. Lactic acid produced was separated and purified using esterification and hydrolysis reactions, respectively, in reactive distillation system. The process was simulated with the aid of the commercial simulator ASPEN PLUS[®]. Operating conditions (temperature, reflux rate, pressure) were obtained from the experimental development, but the plant was simulated for a larger production capacity.

2.2. PLA Synthesis Process Simulation

The lactic acid polymerization was divided in three stages: oligomers formation, lactide obtaining and PLA generation. Initially, the lactic acid solution from fermentation section is fed to the oligomerization reactor where the lactic acid solution is concentrate by removing water. The resulting product contains a mixture of lactic acid and predominately linear oligomers in an aqueous solution. It is carried out by means of a CSTR reactor and a distillation column to recycled lactic acid. The dimer formation is the next stage of PLA polymerization; it is used a stannous catalyst (tin octonate) and the principal reagent is the PLA from the oligomer reactor. A CSTR reactor was used to decompose the oligomers to form lactide. The stream product of the depolymerization reactor includes lactide, water, lactic acid, and some linear oligomers. This stream is connected to the lactide purification system that includes a flash evaporator and distillation columns in sequence, which separate the dimmer of the others products. Lactid acid and water

are recycled to the oligomer formation stage. The catalyst is recovered and a purge stream is used to prevent accumulating in the reactor. Lactide from the second stage of the plant is mixed with an appropriate polymerization catalyst in a CSTR reactor. The lactide polymerizes to polylactide, resulting a mixture which is passed on to a multistage evaporation where two separators blocks are used to remove the catalyst (simulating the catalyst neutralization) and to obtain the purified PLA.

3. Results

3.1. Fermentation Process

Figure 1 shows the simulation flowsheet of the lactic acid production process from sucrose as well as the purification of the acid using esterification and hydrolysis reactions, respectively, in reactive distillation systems. The fermentation reaction was conducted at 307.15 K and 1 atm with massic fraction of sucrose and water of 0.4 and 0.6, respectively. The hydrolysis and esterification reactions were conducted at 353.15 K and 393.15 K, respectively.

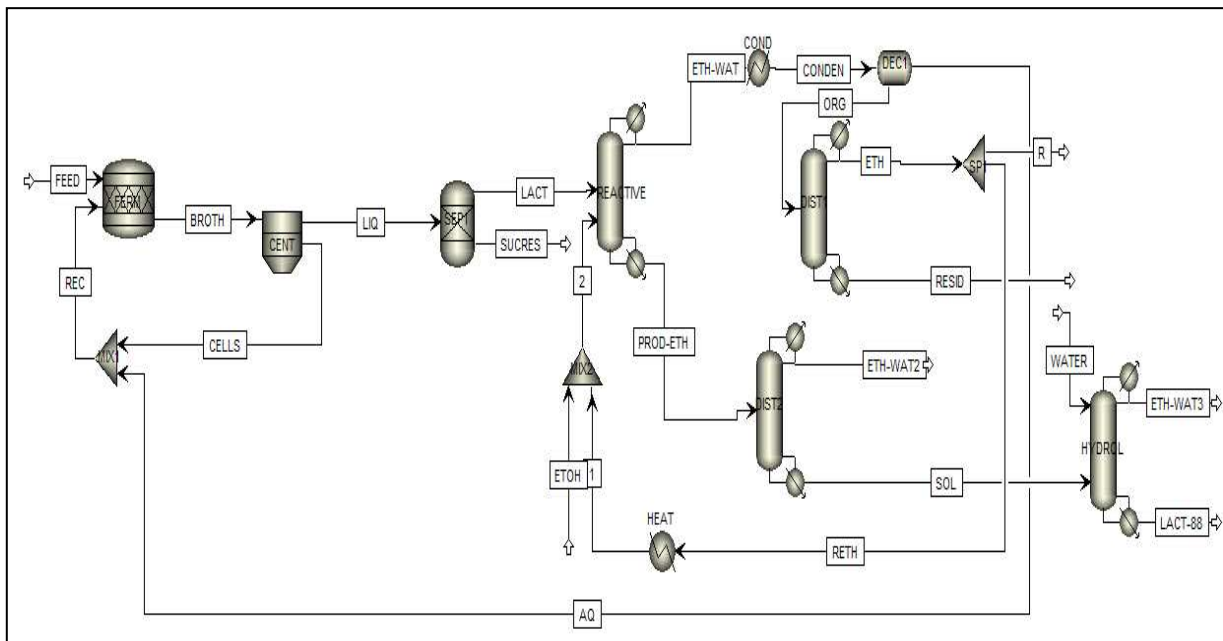

Figure 1. Flowsheet of the lactic acid production

3.2. Polymerization Process

The full process of PLA polymerization is depicted in Figure 2. The aim of the first part of this process (Oligomerization) was to obtain PLA oligomers of low molecular weight without any type catalyst. To achieve the highest mass flow of PLA, the reactor (OLIG-R) must be operated at vapor-liquid phase, temperature 483.15 K, press 2 atm, condensated phase with volume of 30 m³ and residence time 3.3 hr. The stream conditions from OLIG-R are indicated in the Table 1.

** Modelagem e simulação do processo de produção de PLA (poli-ácido láctico) obtido a partir de fontes renováveis para uso biomédico **

To produce the lactide is necessary to use another CSTR reactor (LACTID-R) which receives the PLA oligomers stream from the previous reactor, mixed with an appropriate stannous catalyst (LIQUID-2). These reactor must be operate in liquid phase, temperature 493.15 K, pressure 0.0132 atm, condensated phase volume of 40 m³ and residence time 0.42 hr, to produce the highest mass flow of Lactide without increase the others components. Properties of input and output LACTID-R streams are showed in the two last column of Table 1. The last section of this polymerization process is the high molecular weight PLA production from lactide. Before entering in the reactor (PLA-R) lactide stream (VAPOR-3) is purified removing water and lactic acid to prevent contamination. The separation process to purify is carried out in two vacuum distillation columns. It is necessary to control the reagent amounts, because if the lactic acid and water content is very high, it is impossible to achieve a high molecular weight polymer. In the other hand, if the acid lactic concentration is very low, the reaction will be slow and the molecular weight of PLA very high. Figure 3 shows the decrease of PLA molecular weight number (MWN) with the inlet ratio LA/Lactide and the catalyst mass flow. In this reaction was used another stannous catalyst and it was obtained polymer with molecular weight of 25183.6. PLA reactor obtains the highest mass flow of PLA at temperature 473.15 K, pressure 0.0132 atm, reactor volume of 1 m³, liquid phase and time reaction 0.12 hr.

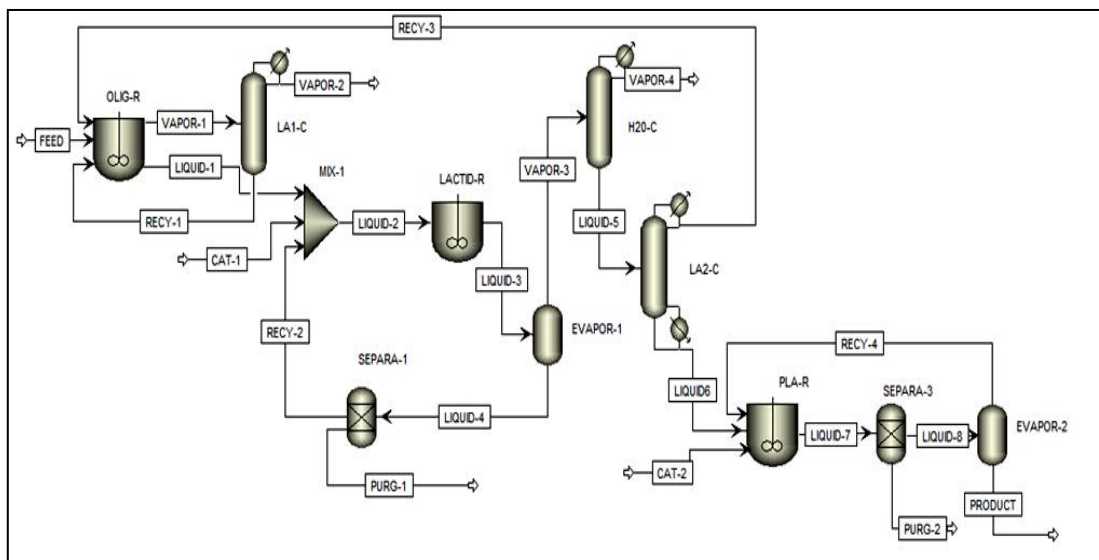

Figure 2. Flowsheet of the PLA polymerization

Table 1. Input and output streams from OLIG-R and LACTID-R.

PROPERTIES	STREAMS						
	OLIGOMER REACTOR				LACTID REACTOR		
	FEED	RECY-1	RECY-3	LIQUID-1	VAPOR-1	LIQUID-2	LIQUID-3
Temperature [K]	298.15	380.98	468.26	483.15	483.15	489.60	493.15
Pressure [atm]	1	0.0132	0.53	2	2	0.53	0.0132
H ₂ O [kg/hr]	1566	0.41	0.35	125.33	3450.64	127.13	407.91
LA [kg/hr]	11484	441.49	472.99	369.12	472.982	415.19	521.27
Lactide [kg/hr]	0	2.56E-19	0	0	0	1737.77	10897.79
PLA [kg/hr]	0	0	0	9547.17	0	105254.90	95708.02
CAT-1 [kg/hr]	---	---	---	---	---	5	5
MWN	---	---	---	569.53	---	779.7174	863.57

Table 2. Input and output streams of PLA-R.

PROPERTIES	STREAMS			
	CAT-2	LIQUID-6	RECY-4	LIQUID-7
Temperature [K]	313.15	419.03	483.15	473.15
Pressure [Atm]	1	0.0132	0.0132	0.013
H2O [Kg/Hr]	0	0	0.11	0.11
LA [Kg/Hr]	0	33.70	22.47	23.97
Lactide [Kg/Hr]	0	9159.90	1659.30	1859.90
PLA [Kg/Hr]	0	0	0	8991.40
CAT-2 [Kg/Hr]	0.1	0	0	0.1
MWN	---	---	---	25183.60

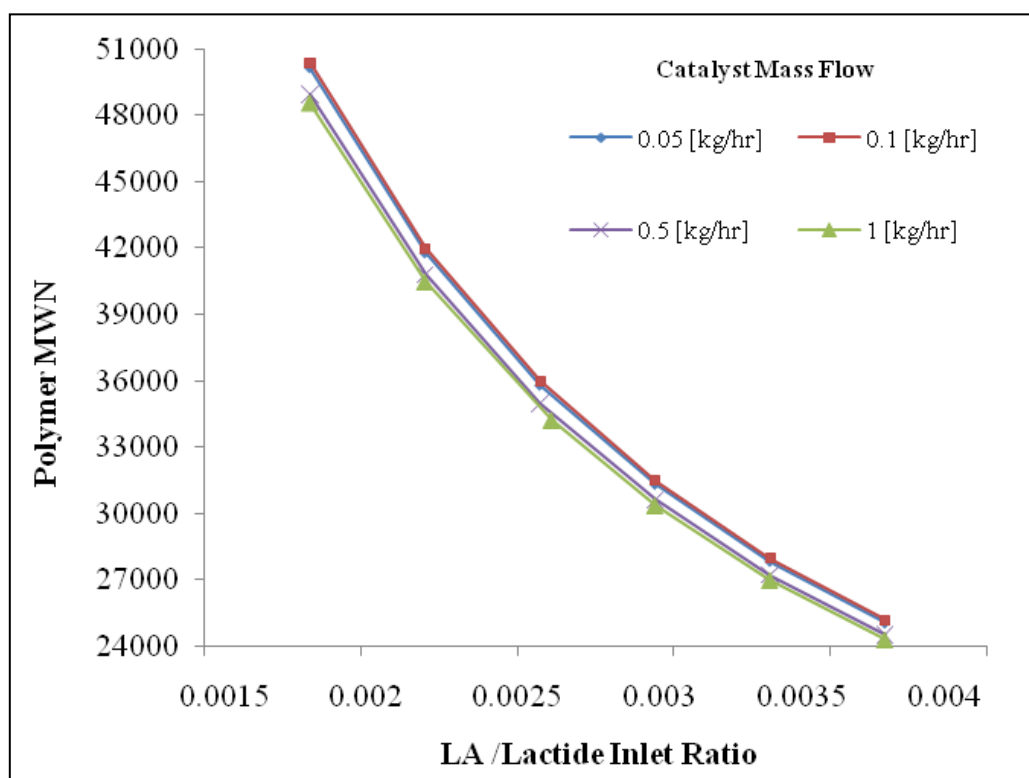

Figure 3. PLA molecular weight number as function of the mass flow variations of reagents and catalyst.

4. Conclusions

It was shown that it is possible produced a high molecular weight PLA from acid lactic obtained through fermentation process. To achieve a high molecular weight polymer it is necessary produce first low molecular weight PLA and then the ciclic dimer (lactide) which is polymerized to obtain the desired PLA. In spite of purification sections are too complicated, these ones are very important in this polymerization because the concentration of reagents affects highly the conditions to achieved better PLA final properties such as high molecular weight number. The simulation process developed is a suitable tool to guide the production of tailor made PLA polymers for biomanufacturing.

References

- Y. Cheng et al., 2009, Poly lactic acid (PLA) Synthesis and Modifications: A Review, *Front. Chem.*, 4, 259-264.
- R. Auras et al, 2010, *Poly (Lactic Acid): Synthesis, Structures, Properties, Processing, and Applications*, John Wiley & Sons, Inc.
- K. Seavey and Y. Liu, 2008, *Step-Growth Polymerization Process Modeling And Product Design*, John Wiley & Sons, Inc..

5.3 Conclusões

Para se obter um polímero de alta massa molar é necessário sintetizar primeiro um polímero de baixa massa molar ou oligômero, e em seguida o dímero cíclico do ácido láctico (lactídeo) é polimerizado para obter o PLA com as características desejadas. Foi demonstrado que pode ser produzido um polímero de ácido láctico (PLA) com uma alta massa molar, a partir de um monômero obtido através de processo de fermentação.

Utilizando um processo que foi dividido em três etapas (oligomerização, formação de lactídeo e polimerização), cada uma delas com um reator que trabalha em sistema contínuo e seu sistema de purificação dos subprodutos no ASPEN PLUS[®], foi possível sintetizar o PLA com massa molar (MWN) de 25183,60. Este valor de massa molar é considerado alto e adequado para aplicações biomédicas.

Não obstante, as separações nas seções de purificação foram muito complexas, devido ao fato de que os componentes do sistema apresentaram similaridade, como é o caso do ácido láctico e o lactídeo. Este fato é importante neste processo de polimerização, porque a concentração dos reagentes em cada um dos estágios afetou fortemente as condições para atingir as melhores propriedades do PLA final, como elevada massa molar e grau de polimerização. O procedimento de simulação desenvolvido foi um instrumento adequado para orientar a produção sob medida de poli(ácido láctico) para biofabricação de implantes e outros dispositivos médicos.

Capítulo 6- Sistema em Batelada

6.1 Introdução

O processo de síntese do PLA é simulado para determinar as melhores condições de operação para a obtenção de altos rendimentos e para a predição e estimação das propriedades finais do produto.

Neste capítulo, foi desenvolvida uma simulação do processo, em batelada, da polimerização do ácido láctico, com o auxílio do simulador comercial ASPEN PLUS[®] e sua ferramenta Polymer Plus, com a finalidade de representar a síntese do PLA a partir do ácido láctico obtido de processo fermentativo. Foi obtido e predito o comportamento do processo estudado, especialmente em relação às variáveis, tais como o número de massa molar do polímero final e o grau de polimerização do mesmo.

6.2 Desenvolvimento

O desenvolvimento deste capítulo é apresentado a seguir, no artigo intitulado “*Modeling and Simulation of the PLA Synthesis from Renewable Feedstocks for Use in Biomedical Field*”, submetido na *XX International Conference on Chemical and Process Engineering, 2011*.

MODELING AND SIMULATION OF THE PLA SYNTHESIS FROM RENEWABLE FEEDSTOCKS FOR USE IN BIOMEDICAL FIELD

Martinez, G. A. R.^{1,2}, Lasprilla, A. J. R.^{1,2}, Figueroa, J. E. J.¹, Jardini, A. L.^{1,2}, Maciel Filho, R.^{1,2}

¹Laboratory of Optimization, Design and Advanced Control, Department of Chemical Processes, School of Chemical Engineering, State University of Campinas, Campinas, SP, Brazil

²Institute of Biofabrication, University City “Zeferino Vaz”, Av. Albert Einstein, 500, ZIP: 13083-852, Campinas, SP, Brazil

Abstract

Recently, different types of biodegradable polymers have been extensively studied for biomedical applications. Besides their wide range of mechanical properties, the biocompatibility and biodegradability of these polymers play important roles in the engineering process for regeneration of tissues. Among these polymers, poly-lactic acid (PLA) and its copolymers have been the most widely used because of their bioresorbable properties. PLA is produced from lactic acid, within a green production, which starts from sucrose obtained from sugarcane molasses as well as from sugars derived from hydrolysis of sugarcane bagasse. In this work, lactic acid polymerization in batch process was simulated by means of ASPEN PLUS® (Polymer Plus) simulator. The kinetic parameters were extracted from current literature. The simulation was developed in order to represent each of the three process stages: oligomerization, lactide formation and final polymerization. Operation conditions, including temperature, pressure and reaction time were determined in each reactor so as to predict the properties of the final product, such as molecular weight number (MWN) and degree of polymerization. Regarding biomedical devices, the fabrication of scaffolds, bone fixation plates and screws requires the use of high molecular weight number PLA. Thus, this simulation allowed for the achievement of the optimal operation conditions for the production of PLA with MWN around 42000.

INTRODUCTION

The term “biomaterials” has alternately been used to describe materials derived from biological sources or to describe materials used for therapies in the human body. The development of bioabsorbable, and biodegradable materials with required characteristics for application in tissue engineering is one of the great challenges of research biomedical field (Lunelli et al., 2010). Poly-lactones such as poly (lactic acid) (PLA), poly-glycolic acid (PGA), and poly-caprolactone (PCL), as well as their copolymers are becoming the most commonly used synthetic biodegradable polymers as fixation devices materials for biomedical devices because their excellent biocompatibility (Cheng et al, 2009). Lactic acid can be produced by fermentative or chemical synthesis. The biotechnological production of lactic acid has received a significant interest, since it is an attractive process in terms of environmental viewpoint as well as economic, due the combination of the low cost of production from sugarcane fermentation, reduction of dependency of fossil based feedstock, reduced CO₂ emission, biocatalyst use and, high specificity of the product and production of optically pure L- or D-lactic acid, depending on the strain selected (Lunelli et al, 2010). The carbon source for microbial production of lactic acid can be either sugar in pure form such as glucose, sucrose, lactose or sugar containing materials such as molasses, whey, sugarcane bagasse,

cassava bagasse, and starchy materials from potato, tapioca, wheat and barley. Sucrose-containing materials such as molasses are commonly exploited raw materials for lactic acid production because represent cheaper alternatives (Lunelli et al, 2010). The chemistry of PLA involves the processing and polymerization of lactic acid monomer. Since, lactic acid is a chiral molecule, PLA has stereoisomers, such as poly-L-lactide (PLLA), poly-D-lactide (PDLA), and poly-D,L-lactide (PDLLA). Isotactic and optically active PLLA and PDLA are crystalline, whereas relatively atactic and optically inactive PDLLA is amorphous (Bouapao et al., 2009). PLA can be prepared by polymerization process of lactic acid, and the polymerization can be realized by direct condensation, ring opening polymerization and enzymatic polymerization. It was simulated Lactic acid polymerization in batch process by means of ASPEN PLUS® (Polymer Plus) simulator in order to represent each of the three process stages: oligomerization, lactide formation and final polymerization. Operation conditions, including temperature, pressure and reaction time were determined in each reactor so as to predict the properties of the final product, such as molecular weight number (MWN) and degree of polymerization.

METHODOLOGY

Currently, direct polymerization and ring opening polymerization are the most used production techniques to produce PLA (Lunelli et al., 2010). Figure 1 shows the main methods of PLA synthesis. In direct condensation, solvent is used under high vacuum and temperatures for the removal of water produced in the condensation. The resultant polymer is a low to intermediate molecular weight material (Gupta et al, 2007). By another hand, to achieve high molecular weight the preparation must be carried out by ring-opening polymerization of the cyclic dimer of lactic acid in the presence of some catalyst. Catalytic ring-opening polymerization of the lactide results in PLA with controlled molecular weight. This molecular weight number is around of 300000 (Cheng et al., 2009).

In this work, it was simulated in Aspen Plus® (Polymers Plus) the PLA synthesis by opening ring of lactide to achieve a final polymer with high molecular weight. It was used a kinetic found in Seavey and Liu (2008). This polymerization process was divided in three main sections, the first one is the lactic acid oligomerization (low molecular weight PLA formation), the second one is the lactide (cyclic dimer) formation and finally the high molecular weight PLA polymerization. The reagents, catalyst, final and intermediated products worked in this process are showed in the Table 1.

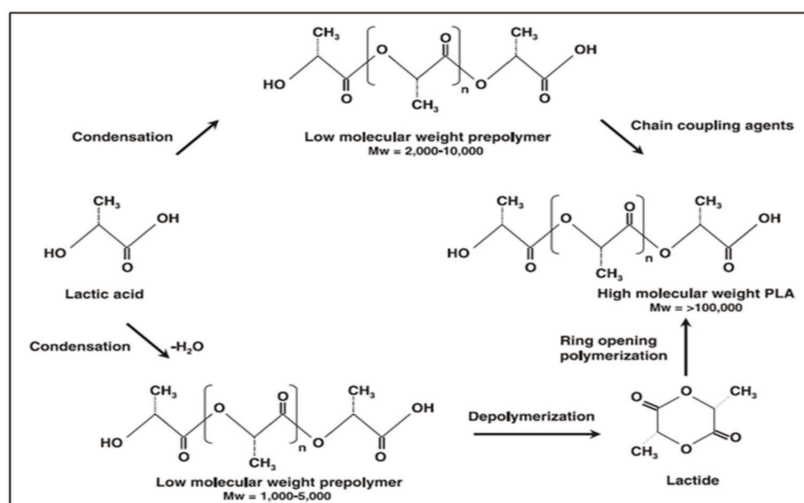

Figure 1: Routes to obtain high molecular weight PLA (Gupta et al, 2007).

Table 1: System Components

COMPONENTS	TYPE	FORMULA
Water	Reagent	H ₂ O
Lactic Acid	Reagent	C ₃ H ₆ O ₃
Lactide	Intermediate Product	C ₆ H ₁₀ O ₅
Poly (lactic acid)	Final Product	C ₃ H ₄ O ₂
Tin Oxide	Catalyst	SnO

The reaction mechanism of PLA polymerization proposed for this process is showed in the next equations. The equations (1-3) represent the oligomers oblation; they are esterification reactions which producing PLA molecules with low molecular weight, and their respective reversible reactions (hydrolysis).



where LA is lactic acid, W is water and, P_n is a oligomer with *n* acid lactic units. When *n*=2 the oligomer is named linear dimer. In the presence of a appropriated catalyst of stannous, the two end groups of the linear oligomer can also react with each other, forming a closed ring structure, this reaction is especially favored for linear dimers, because the resulted molecule is very stable (Lactide). The equation (4) represents this reaction and its reverse reaction (hydrolysis).



where P₂ is a linear dimer, C₂ is a cyclic dimer and W is water. In the polymerization section, lactide is polymerized through ring opening and ring addition reactions in the presence of catalyst and trace amounts of water and lactic acid; it is represented by the equations (5-6).

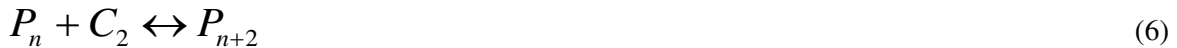

Due to absence of water and lactic acid grate amounts, the P_n molecule has a high repeat unit amount, creating a high molecular weight polymer.

RESULTS AND DISCUSSION

Figure 2 shows the polymerization process flowsheet. In this figure can be observed three principals sections of this process, each one of them has one batch reactor used like principal unit. It is two distillations columns and one evaporator to purify the components when is necessary to achieve some

• *Modelagem e simulação do processo de produção de PLA (poli-ácido láctico) obtido a partir de fontes renováveis para uso biomédico* •

especially properties in the final polymer. In the Table 2 presents the properties and the mass flows of the main streams of this process. The first reactor (OLIG-R) produces PLA oligomers with 783.51 molecular weight number and the last one (PLA-R) achieves the same polymer with 42340.51.

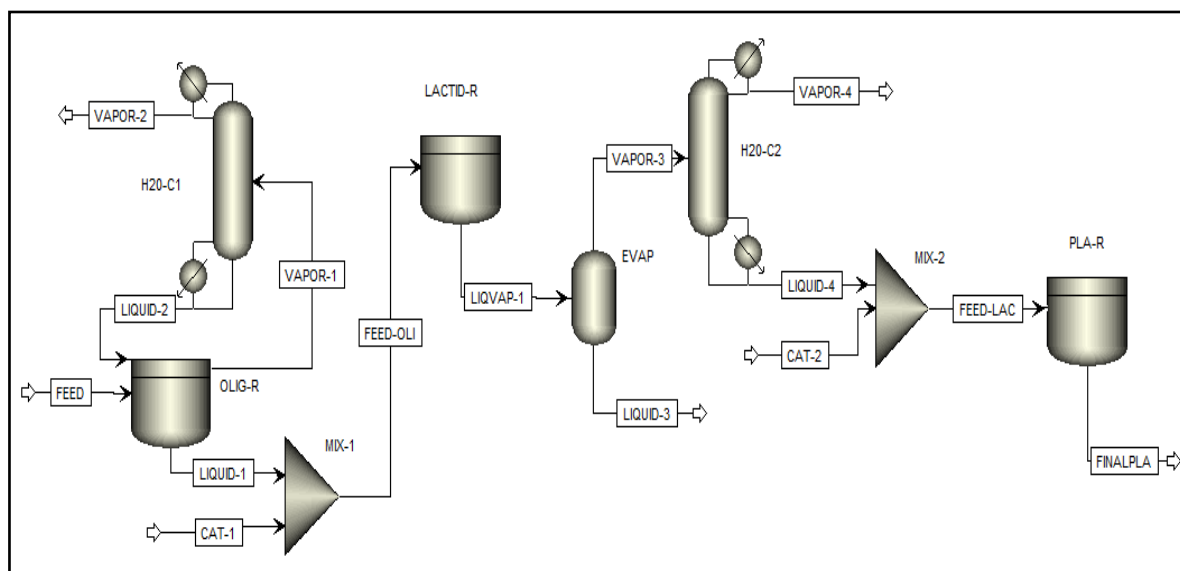

Figure 2: PLA process flowsheet.

Table 2: System Components

PROPERTIES	FEED	FEED-OLI	LIQVAP-1	FEED-LAC	FINAL PLA
Temperature [K]	298.15	483.85	473.15	406.95	433.15
Pressure [atm]	1	1	0.0131	0.0131	1
H ₂ O [kg/hr]	0.15	0.0041	0.0228	0.0002	8.9271e-07
LA [kg/hr]	0.85	0.0153	0.0002	0.0002	4.0572e-08
Lactide [kg/hr]	---	---	0.6732	0.6712	0.0566
PLA [kg/hr]	---	0.6833	0.0065	---	0.6150
CAT-1 [kg/hr]	---	0.01	0.01	0.01	0.01
MWN	---	783.51	6885.23	---	42340.51

The oligomerization reactor was operated without catalyst, in 483.15 K, 1 atm and liquid/vapor phase. The tin oxide is fed to lactide production in the second reactor, in which the operations conditions are 473.15 K, vacuum (0.0131 atm) and liquid/vapor phase. To produce PLA with 42340.51 of molecular weight number the polymerization reactor must be work in 433.15 K, 1 atm and liquid/vapor. The Figure 3 shows the components behavior (main reagent and main product) along of the reaction total time in the three batch reactors. It is can be possible to observe how increase a mass flow component in one reactor, and in the next decrease because it becomes in reagent.

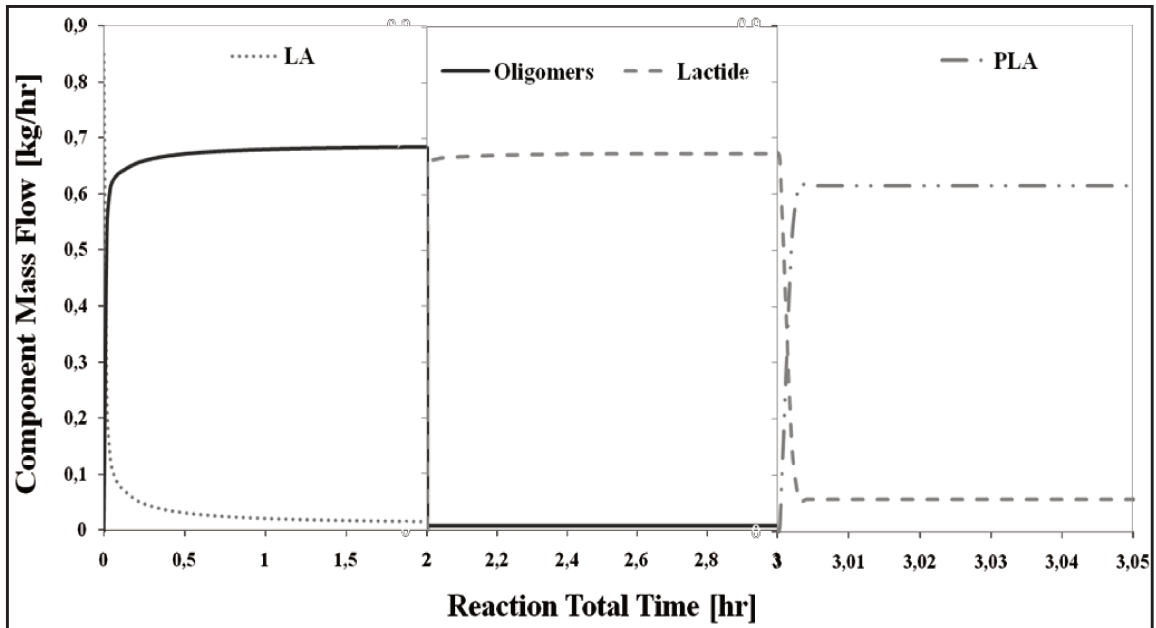

Figure 3: Behavior of the components mass flow in the reactors.

The total process time is 3 hours and 5 minutes, without time-off. The oligomerization production is carried out in 2 hours, the second part of the process (lactide synthesis) is done in one hour, and the final reaction is brought out in 5 minutes. Figure 4 shows the changes of the polymer properties, such as molecular weight number and polymerization degree as function of water/lactide ratio in the PLA reactor inlet. It is possible to observe that when a lower water/lactide ratio is used, there is an increase in molecular weight number and degree of polymerization. So, it is necessary to separate the greater amount of water possible before the reaction beginning, to achieve a polymer with high molecular weight.

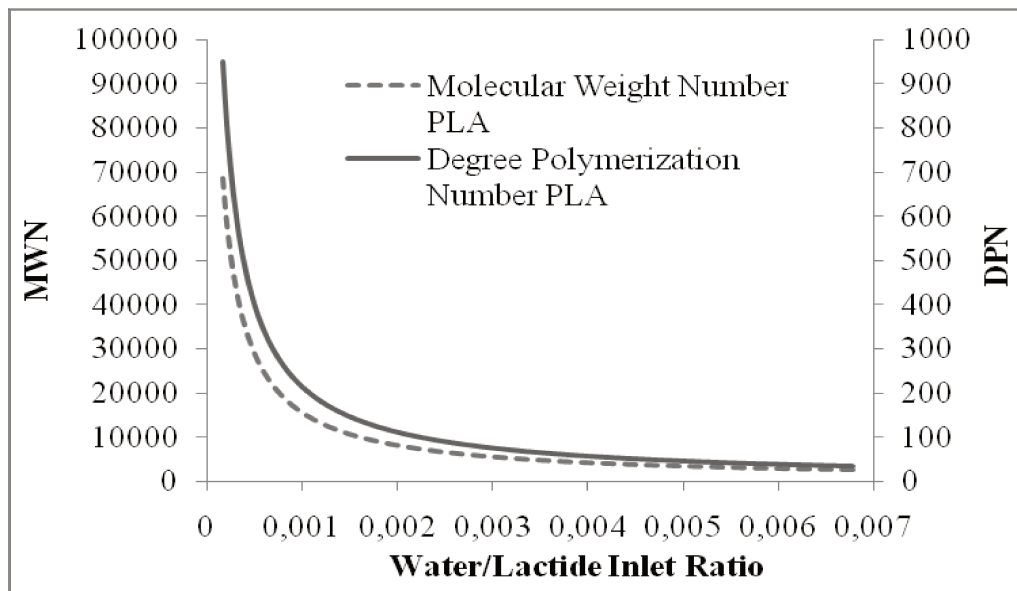

Figure 4: Behavior of final PLA properties.

CONCLUSIONS

It was shown that it can be produced poly (lactic acid) (PLA) with high molecular weight (MWN) from lactic acid by means of ASPEN PLUS®, using batch reactors. The molecular weight of PLA that was obtained was 42340.51, which is considered high and a great value according to Cheng et al. 2009 to be used such as a polymer in manufacturing of "scaffolds" and biomedical devices. To achieve PLA with high molecular weight, it was necessary to use three batch reactors in series, getting two byproducts, a low molecular weight polymer, named as oligomer and a cyclic dimer of lactic acid, called lactide, these was produced in the first and second reactor respectively. The final polymer is synthesized by ring opening of lactide, in the last reactor of this synthesis process. The variables values, degree polymerization and molecular weight number of the final polymer (PLA), decrease when the ratio between, water amount and lactide amount that are fed into the final reactor (PLA-R), increases. Therefore, to obtain a polymer with high molecular weight, it is necessary to separate the higher water amount possible before the reaction beginning. With the kinetics used in this simulation, it can be observed a behavior of reactants rapid consumption in the three reactors. In the oligomerization reactor (OLIG-R), the time at which it reaches the higher mass flow of PLA with low molecular weight number is 2 hours. In the lactide production reactor (LACTID-R), the highest mass flow of product is reached one hour after the reaction start. In the last reactor, the reaction rate is very high, achieving in 5 minutes the highest mass flow of poly (lactic acid), becoming the final time process, without time-off , 3 hours and 5 minutes.

REFERENCES

- Bouapao, L., Tsuji, H., Tashiro, K., Zhang, J. and Hanesaka, M. (2009), Crystallization, spherulite growth, and structure of blends of crystalline and amorphous poly(lactide), *Polymer*, 50, 4007-4017.
- Cheng, Y., Deng, S., Chen, P. and Ruan R. (2009), Polylactic acid (PLA) synthesis and modifications: a review, *Frontiers of Chemistry in China*, 4, 259-264.
- Gupta, B., Revagade, N. and Hilborn, J. (2007), Poly(lactic acid) fiber: An overview, *Progress in Polymer Science*, 34, 455-482.
- Lunelli, B.H., Lasprilla, A.J.R., Martinez, G.A.R., Jardini, A.L. and Maciel Filho, R. (2010) Poly-lactic acid production from brazilian renewable feedstock for application in biomedical devices, 6° Latin American Congress of Artificial Organs and Biomaterials, 216-2.
- Seavey, K.C. and Liu, Y.A., Eds., 2008, Step-Growth Polymerization Process Modeling and Product Design. John Wiley & Sons, Inc..

6.3 Conclusões

Foi demonstrado, por simulação em ASPEN PLUS[®], que é possível produzir PLA com elevada massa molar (MWN) a partir do ácido láctico, utilizando reatores em batelada. O PLA obtido apresentou massa molar de 42340,51, valor que pode ser considerado alto e ótimo, segundo Cheng *et al.* (2009), para fabricação de *scaffolds* e dispositivos biomédicos.

Para atingir o PLA com alta massa molar, foi necessário utilizar três reatores em batelada e em série, obtendo-se dois subprodutos: um polímero de baixa massa molar, chamado oligômero e um dímero cíclico do ácido láctico, chamado lactídeo, produzidos no primeiro e no segundo reator, respectivamente. O polímero final foi sintetizado, no último reator do processo, por meio da abertura de anéis do lactídeo.

Os valores das variáveis, grau de polimerização e número de massa molar do polímero final (PLA) diminuíram quando a razão entre a quantidade de água e lactídeo alimentados no reator final (PLA-R), aumentou. Portanto, para obter um polímero de alta massa molar é necessário separar a maior quantidade de água possível, antes de iniciar a última reação.

Com a cinética utilizada na simulação, observou-se um comportamento rápido de consumo dos reagentes nos três reatores. No reator de oligomerização (OLIG-R), o tempo no qual se atingiu o fluxo mássico de PLA de baixa massa molar foi 2 horas. No reator de produção de lactídeo (LACTID-R), o máximo fluxo mássico de produto foi atingido após uma hora de iniciada a reação. No último reator (PLA-R), a velocidade da reação foi muito elevada, atingindo em 5 minutos o fluxo de massa máximo de poli (ácido láctico), permanecendo o tempo final de processo em 3 horas e 5 minutos.

Capítulo 7- Análises das Variáveis do Processo

7.1. Introdução

Neste capítulo, a produção de poli (ácido láctico) por polimerização e abertura de anéis foi avaliada com um simulador comercial (ASPEN PLUS[®]) com o auxílio de sua ferramenta (Polymer Plus), visando encontrar a relação das propriedades de polímeros com as condições operacionais para obter um produto final desejado. Foi utilizada a simulação realizada no Capítulo 6, que utilizou uma cinética disponível na literatura (Seavey e Liu, 2008) e desenvolvida em reatores em batelada.

Foram realizadas as simulações necessárias para fazer um planejamento experimental com dois níveis de fatores e quatro variáveis, fazendo-se o teste de curvatura para se identificar a necessidade de se construir um modelo estatístico não linear. Isto foi realizado para cada etapa do processo, com o objetivo de conhecer o comportamento de algumas variáveis, quando outras são alteradas.

Foram utilizados os modelos estatísticos para prever o comportamento das variáveis escolhidas, bem como analisados os efeitos de cada variável estudada, visando identificar quais produzem efeitos significativos nas respostas. Este procedimento foi realizado por meio de um *software* estatístico (STATISTICA 7.0). Foram realizados testes F para verificar se os modelos encontrados eram preditivos ou não, com relação ao comportamento das respostas obtidas. Com o auxílio da análise dos gráficos de superfície de resposta e derivadas dos modelos, foi possível obter os valores ótimos das variáveis estudadas.

7.2 Desenvolvimento

O desenvolvimento deste capítulo é apresentado a seguir, no artigo intitulado “*Variable Variable Behaviors of the Poly (Lactic Acid) Synthesis in Batch Process Simulation*”, que se encontra em fase de submissão.

VARIABLE BEHAVIORS OF THE POLY (LACTIC ACID) SYNTHESIS IN BATCH PROCESS SIMULATION

Guillermo A. R. Martinez^{1,2}, Astrid J. R. Lasprilla^{1,2}, Jaiver E. J. Figueroa¹
André L. Jardini^{1,2}, Rubens Maciel Filho^{1,2}

¹Laboratory of Optimization, Design and Advanced Control, School of Chemical Engineering, State
University of Campinas, Campinas (SP), Brazil

²Institute of Biofabrication, Campinas (SP), Brazil
E-mail: grueda@feq.unicamp.br

Abstract

Currently, research in the biomedical field aims at replacing conventional non-reabsorbable materials with biodegradable and bioabsorbable polymers. Poly (Lactic Acid) (PLA,) is one of the most promising biopolymers due to its tunable properties and because it is made from renewable resources (Mikos and Temenoff, 2000). PLA synthesis requires rigorous control of conditions (temperature and vacuum), the use of catalysts and long polymerization times, which implies high energy consumption. In order to maximize the benefits of its use, it is necessary to understand the relationship between PLA material properties, the manufacturing process and the final product with desired characteristics. In this paper, Poly (Lactic Acid) production by ring opening polymerization is investigated using a commercial simulator (ASPEN PLUS®) with its tool (Polymer Plus) to find the relation of polymer properties with operational conditions to obtain a final product with desired characteristics. Simulations to make the full design of experiments with two-level factors and the composite central analysis of experiments were carried out for each process stage, with the purpose of finding some variable responses behavior when other are altered. Statistical models were used to predict the behavior of the chosen variables, and the effects of each studied variable were analyzed, in order to find significant variables.

1. INTRODUCTION

Currently, research in the biomedical field aims at replacing conventional non-reabsorbable materials with biodegradable and bioabsorbable polymers. Poly (Lactic Acid) (PLA,) is one of the most promising biopolymers due to its tunable properties and because it is made from renewable resources. Lactic acid can be made by fermentation of sugars obtained from renewable resources such as sugarcane and corn (Lasprilla et al., 2011). Ultimately, it may be the polymer with the broadest range of applications because of its ability to be stress crystallized, thermally crystallized, impact modified, filled, copolymerized, and elaborated in most polymer processing equipment (Henton et al., 2005). PLA polymers can be synthesized by different processes from lactic acid the products fabricated have a wide variety of chemical and mechanical properties (Lasprilla et al., 2011). The properties of lactic acid based polymers vary to a large extent depending on the ratio between the two stereoisomers or other comonomers as well as their distribution (Auras et al., 2010).

The first commercial products of lactic acid based polymers introduced in the market were in medical applications, and this product field is still an important one. Over the past two decades, there has also been an increase in large-scale industrial production for commodity use and several companies have become active in manufacturing large volumes of PLA (Auras et al., 2010; Henton et al., 2005). Cargill Dow LLC developed and patented a low-cost continuous process for the production of lactic acid-based polymers. The process combines the production of lactic acid by fermentation of dextrose, followed by the manufacture of low molecular weight PLA prepolymer by continuous condensation. Subsequently, these oligomers are converted into a mixture of lactide stereoisomers using a catalyst which is then purified by vacuum distillation. Finally, PLA high polymer is produced using a tin catalyst by ring-opening lactide polymerization in melt (Henton et al., 2005).

Although there are multiple ways to fabricate PLA, none of them is simple or easy to execute. PLA synthesis requires rigorous control of conditions (temperature and vacuum), the use of catalysts and long polymerization times, which implies high energy consumption. In order to maximize the benefits of its use, it is necessary to understand the relationship between PLA material properties, the manufacturing process and the final product with desired characteristics. However, it is not easy experimentally to find the optimal values of the variables involved to achieve the required properties because it is time consuming and expensive (Martinez et al., 2011). In this paper, PLA production by ring opening polymerization is studied in a commercial simulator (ASPEN PLUS[®]) to find the relation of polymer properties with the operational conditions to obtain a final product with desired characteristics.

2. METHODOLOGY

PLA synthesis can be simulated in a batch process in ASPEN PLUS[®] software using its tool Polymer Plus in order to achieve high molecular number. The simulation of this synthesis was developed in a previous work using kinetic data which was taken in Seavey and Liu (2008); the flowsheet PLA synthesis process is presented in Figure 1. This process has three sections, each one takes place in a batch reactor. Each individual process can be optimized respect to one or more variables in order to achieve better conditions or desired properties. The technique of parametric sensitivity analysis was used to predict the behavior of the chosen variables. Also, STATISTICA 7.0 was used in order to find the effects of each variable over the responses. Full designs of experiments were carried out with test of curvature in order to confirm if the model is linear or quadratic. Furthermore, a composite central analysis of experiments was conducted so as to find quadratic models and response surfaces to observe the behavior of these variables. As a result, the values to maximize or minimize the response according to the requirements were obtained.

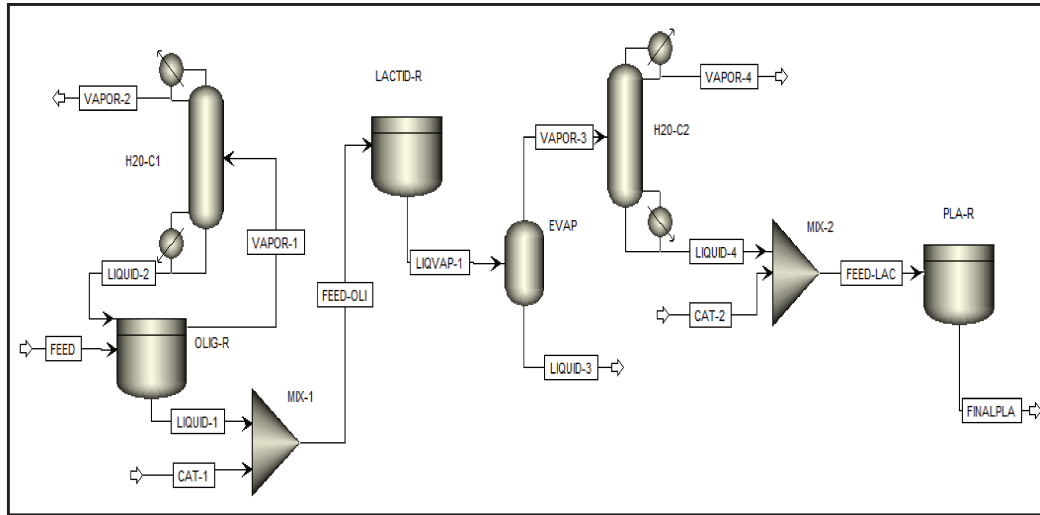

Figure 1. Flowsheet of poly (lactic acid) synthesis in batch process.

The first part of the global process is the oligomeric PLA production; the variables which were utilized as response variables are: PLA Mass Flow, because it is the principal reagent in the second stage, and the molecular weight number. According with Yoo and Kim (2006), to maximize the lactide obtained in this process, the best oligomeric PLA MWN is around 1400. Having these conditions defined, the next stage (lactid synthesis) was performed, in which Lactide Mass Flow and Purity Lactide were selected as response variables. These variables were chosen because Lactide is the principal reagent in the final stage process and its purity according with Auras et al. (2010) is very important to obtaining high molecular weight PLA. At last, in the synthesis of final PLA, the variables considered as response variables are, the PLA Mass Flow, their Purity and the Molecular Weight Number. According with Kricheldorf and Lee (1995), the PLA biomedical application depends on this Molecular Weight Number. Figure 2 represents a block chart of the synthesis process and this shows the variables on the top of each reactor and the responses on the right side of them.

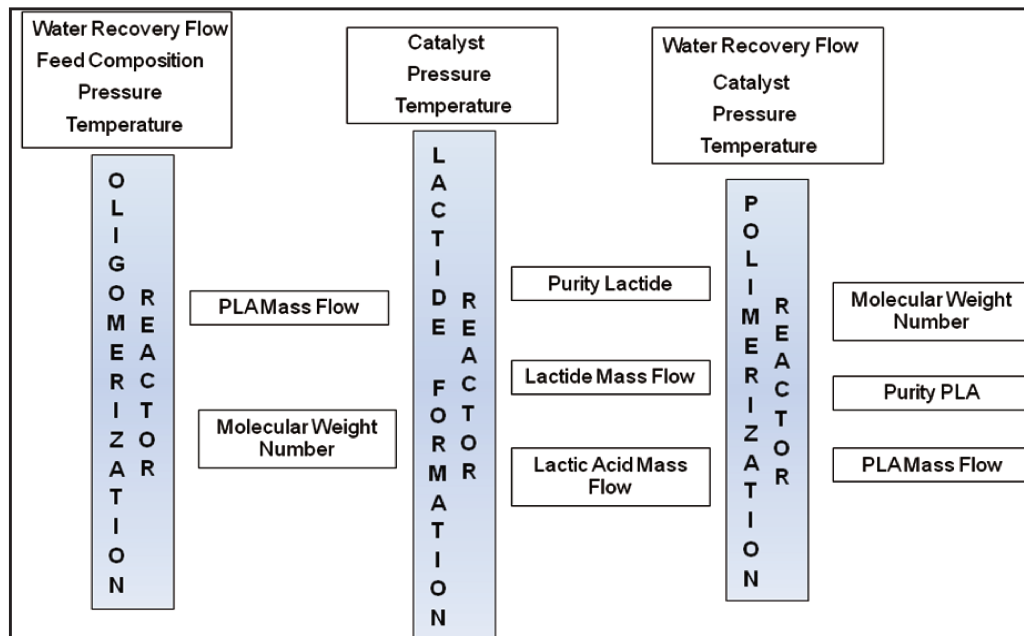

Figure 2. Block chart of poly (lactic acid) synthesis in batch process.

3. RESULTS

3.1. OLIGOMER REACTOR

3.1.1. Full design of experiments

The first part of the PLA synthesis process is the oligomerization production or PLA low molecular weight formation; this stage was conducted in a batch reactor. Simulations to make the full design of experiments with two-level factors and four variables were carried out. Table 1 shows the tests performed with the independent (Feed Composition, Temperature, Pressure and Water Recovery Column) and the dependent variables (PLA Mass Flow and Molecular Weight Number).

Table 1. Full design of experiments Matrix 2^4 , variables and responses.

TESTS	FC	T	P	WRC	PMF	MWN
1	-1	-1	-1	-1	0.3910	1036.209
2	-1	-1	-1	+1	0.3910	1041.002
3	-1	-1	+1	-1	0.3999	474.444
4	-1	-1	+1	+1	0.3998	474.577
5	-1	+1	-1	-1	0.3940	1462.270
6	-1	+1	-1	+1	0.3940	1474.177
7	-1	+1	+1	-1	0.4032	622.222
8	-1	+1	+1	+1	0.4031	622.379
9	+1	-1	-1	-1	0.7434	1041.004
10	+1	-1	-1	+1	0.7431	1042.039
11	+1	-1	+1	-1	0.7604	474.860
12	+1	-1	+1	+1	0.7604	474.887
13	+1	+1	-1	-1	0.7473	1471.454
14	+1	+1	-1	+1	0.7475	1474.124
15	+1	+1	+1	-1	0.7663	622.442
16	+1	+1	+1	+1	0.7662	622.482
17	0	0	0	0	0.6840	702.670

FC: Feed Composition - T: Temperature - P: Pressure - WRC: Water Recovery Column
PMF: PLA Mass Flow - MWN: Molecular Weight Number

The values of the variable levels are listed in the Table 2.

Table 2. Variables and values oligomerization stage.

VARIABLE	-1	0	1
Feed Composition [%]	75	85	95
Temperature [°C]	190	205	220
Pressure [atm]	0.3	1.15	2
Water Recovery Column	0.9	0.95	0.9999

The first response that was analyzed by means of statistic software was the PLA Mass Flow. A 95% confidence interval and residual error were used. It was worked with effects of three ways interactions between variables. Table 3 shows the variables effects that are significant and which are not. Throughout the technique of parametric sensitivity analysis the effect of each operational variables and the interaction between them were quantified. The lines from Table 2 which are outstanding and have the asterisk (*) represent the significant effects.

Table 3. Effects and statistics data for PLA Mass Flow.

FACTORS	Effect	Standard Error	t(1)	p
Mean/Interac.*	0.674994	0.000042	16162.93	0.000039
Curvature*	0.018018	0.000344	52.32	0.012166
(1)WRC	-0.000154	0.000084	-1.85	0.315599
(2)P*	0.015699	0.000084	187.95	0.003387
(3)T*	0.004874	0.000084	58.35	0.010909
(4)FC*	0.158661	0.000084	1899.59	0.000335
1 by 2	0.000045	0.000084	0.54	0.686734
1 by 3	0.000018	0.000084	0.22	0.863569
1 by 4	0.000044	0.000084	0.53	0.692220
2 by 3	0.000493	0.000084	5.90	0.106886
2 by 4*	0.002289	0.000084	27.41	0.023216
3 by 4	0.000128	0.000084	1.54	0.367548
1*2*3	-0.000063	0.000084	-0.76	0.587510
1*2*4	-0.000041	0.000084	-0.49	0.710410
1*3*4	0.000083	0.000084	0.99	0.501950
2*3*4	0.000378	0.000084	4.53	0.138273

p: significance probability. *: statistically significant effect

In Table 3, it is possible to observe that the following variables have significant effects over the PLA Mass Flow (PMF): Feed Composition (4), Pressure (2), Temperature (3) and the interaction between (2) by (4). These variable effects and the mean are statistically significant values for a confidence interval of 95%, because they did not present *p* values superior than 0.05 (Barros et al., 2007; Rodrigues and lemma, 2005). However, the second line in Table 3 represents the curvature test which in this case is significant. For this reason it was not possible to generate some linear model to predict this response behavior; it is necessary to use a quadratic model.

The other studied response of the oligomerization synthesis was the Molecular Weight Number (MWN); this one was analyzed with the technique of parametric sensitivity analysis, as well. It is possible to say that Temperature (3), Pressure (2) and the interaction between them (2) by (3) are statistically significant for confidence limit of 95%; that is observed in Table 4. Since the curvature test is significant, the model to predict this response (MWN) has to be a quadratic model. In this response, neither the Water Recovery Column (1) nor the PLA Mass Flow was significant.

Table 4. Effects and statistics data for Molecular Weight Number.

FACTORS	Effect	Standard Error	t(1)	p
Mean/Interac.*	902,527	0,098873	9128,11	0,000070
Curvature*	-399,714	0,815331	-490,25	0,001299
(1)WRC	1,449	0,197747	7,33	0,086362
(2)P*	-707,875	0,197747	-3579,70	0,000178
(3)T*	289,556	0,197747	1464,28	0,000435
(4)FC	0,768	0,197747	3,88	0,160491
1 by 2	-1,414	0,197747	-7,15	0,088478
1 by 3	0,625	0,197747	3,16	0,195141
1 by 4	-0,506	0,197747	-2,56	0,237239
2 by 3*	-141,906	0,197747	-717,61	0,000887
2 by 4	-0,613	0,197747	-3,10	0,198798
3 by 4	-0,128	0,197747	-0,65	0,634673
1*2*3	-0,603	0,197747	-3,05	0,201659
1*2*4	0,504	0,197747	2,55	0,237934
1*3*4	-0,213	0,197747	-1,08	0,476522
2*3*4	0,066	0,197747	0,34	0,793845

p: significance probability. *: statistically significant effect.

3.1.1. Central composite analysis of experiments

In the both responses of this oligomerization synthesis, the variable Water Recovery Column (1) is not significant, therefore, this was not considered in the following analysis. The curvature test is significant, for this reason, it is necessary to carry out a central composite analysis of experiments with two-level factors and three variables, to find a quadratic model in order to predict the response behaviors. In Table 5 is shown the new experimental design matrix.

Table 5. Central composite analysis of experiments matrix 2^3 , variables and responses.

TESTS	FC	T	P	PMF	MWN
1	-1	-1	-1	0.6313	840.78
2	-1	-1	+1	0.6352	547.76
3	-1	+1	-1	0.6313	995.66
4	-1	+1	+1	0.6371	643.52
5	+1	-1	-1	0.7264	840.96
6	+1	-1	+1	0.7310	547.86
7	+1	+1	-1	0.7264	995.72
8	+1	+1	+1	0.7331	643.56
9	+1.68	0	0	0.7645	702.83
10	-1.68	0	0	0.6033	702.68
11	0	+1.68	0	0.6843	801.92
12	0	-1.68	0	0.6829	610.16
13	0	0	+1.68	0.6836	546.57
14	0	0	-1.68	0.6670	1232.22
15	0	0	0	0.6838	702.71

FC: Feed Composition - T: Temperature - P: Pressure
PMF: PLA Mass Flow - MWN: Molecular Weight Number

The values of the variable levels are listed in the Table 6.

Table 6. Variables and values.

VARIABLE	-1.68	-1	0	1	1.68
Feed Composition [%]	75	79.05	85	90.95	95
Temperature [°C]	190	196.07	205	213.93	220
Pressure [atm]	0.3	0.64	1.15	1.66	2

In Figure 3 and Table 5 are shown the variable effects over de the PLA Mass Flow. The effects which are after the red line ($p=0.5$) are the significant effects (Figure 3). These also appear with a asterisk (*) in Table 7.

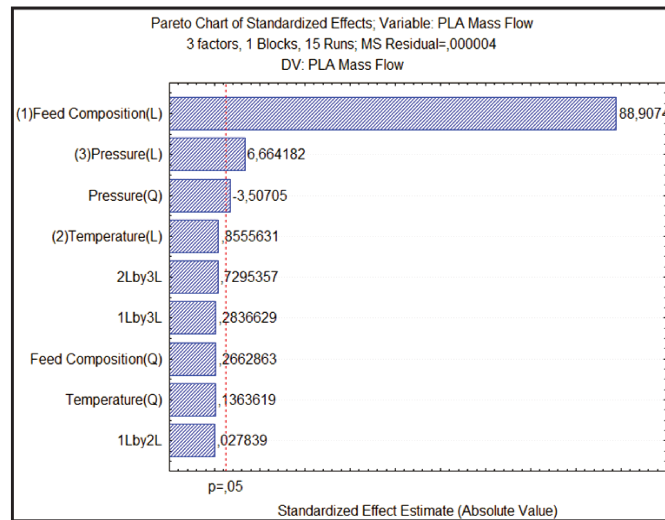

Figure 3. Pareto Chart for PLA Mass Flow.

The linear effect of Feed Composition (1), the linear and the quadratic effect of Pressure (3) are significant over the PLA Mass Flow in a confidence limit of 95% and residual error.

Table 7. Effects and statistics data for PLA Mass Flow.

FACTORS	Effect	Standard Error	t(1)	p
Mean/Interac.*	0.683700	0.001975	346.1608	0.000000
(1)FC (L)*	0.095675	0.001076	88.9074	0.000000
FC (Q)	0.000431	0.001617	0.2663	0.800651
(2)T (L)	0.000921	0.001076	0.8556	0.431318
T (Q)	0.000221	0.001617	0.1364	0.896856
(3)P (L)*	0.007171	0.001076	6.6642	0.001148
P (Q)*	-0.005671	0.001617	-3.5071	0.017155
1L by 2L	0.000039	0.001405	0.0278	0.978868
1L by 3L	0.000399	0.001405	0.2837	0.788039
2L by 3L	0.001025	0.001405	0.7295	0.498401

p: significance probability. *: statistically significant effect.

The model which represents the PLA Mass Flow behavior is shown in Equation (1) and its coefficient is taken of the Statistic 7.0.

$$PMF = 0.684110 + 0.047838 \cdot FC + 0.003586 \cdot P - 0.002960 \cdot P^2 \quad (1)$$

To confirm if this model describes well the response behavior, it is necessary to make a variance test. This test consists in calculating an F value with the mean squares taken from the statistic software, and compares it with a founded F in the literature (Barros et al., 2007; Rodrigues and lemma, 2005). If the calculated value is higher than the other one, this means that the model it is a good tool to predict the PLA Mass Flow behavior in the oligomerization reactor (OLIG-R). In this case, the test was done in equation (2) and (3).

- F Test:

$$F_{calculated} = \frac{MS_R}{MS_r} \gg F_{3,11} (95\%) = 3.59 \quad (2)$$

$$F_{calculated} = \frac{MS_R}{MS_r} = \frac{0.01050056}{0.000002} = 4556.11 \checkmark \quad (3)$$

Since the F test was approved in this case, it is possible to confirm that this model represents and predicts the PLA Mass Flow behavior; in addition, the R square is 0.9992. To find the variable values which maximize the response, it is analyzed the model establish. The variable Feed Composition (1) has only the linear effect as significant and its term in Equation (1) is positive, so, when is worked in the highest studied level (+1.68), it is maximizing the response (PMF). For the variable Pressure (3), as this one has its quadratic coefficient negative, it is possible find a maximum value, deriving Equation (1) and doing it equal to zero.

$$\frac{\partial(PMF)}{\partial(P)} = 0.003586 - 0.00592 \cdot P = 0 \quad P = 0.6057 \quad (4)$$

When the value of Pressure (3) is 0.6057, the response (PMF) achieves its maximum value. The values not coded are: Feed Composition (1.68) (95% or 0.95) and Pressure (3) (1.46 atm); Temperature (2) and Water Recovery Column (4) are not high significant to this response in the range studied. Figure 4 possible shows the response surface plot.

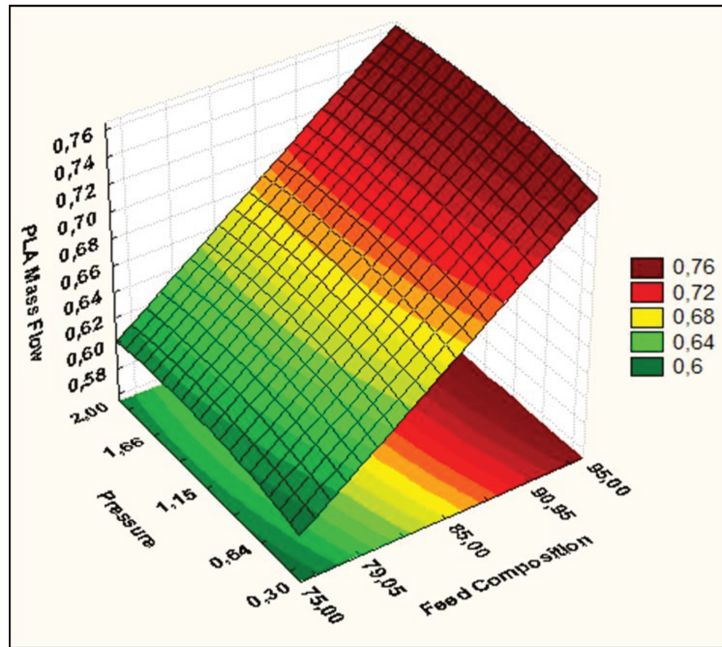

Figure 4. Response surface plot for PLA Mass Flow.

The next response is the Molecular Weight Number (MWN). For this response are significant the linear effect of Temperature (2) and the both effects of Pressure (3); that can be observed in Figure 5 and Table 8.

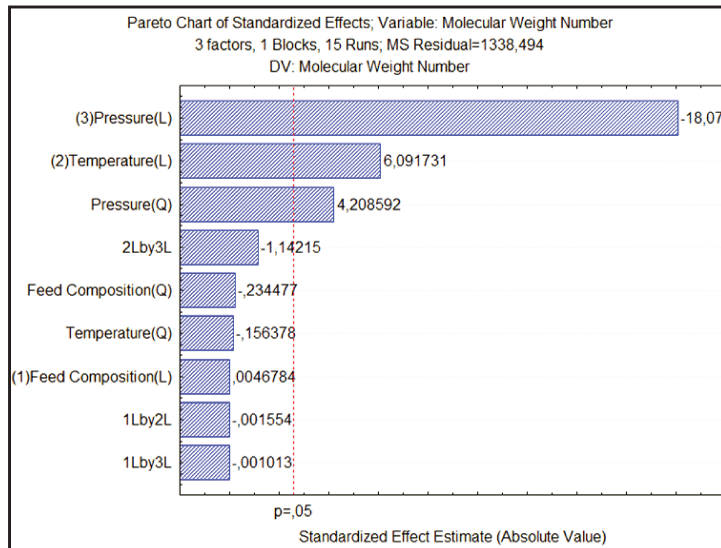

Figure 5. Pareto Chart for Molecular Weight Number.

Table 8. Effects and statistics data for Molecular Weight Number.

FACTORS	Effect	Standard Error	t(5)	p
Mean/Interac.*	705.308	36.35642	19.3998	0.000007
(1)FC (L)	0.093	19.80864	0.0047	0.996448
FC (Q)	-6.980	29.76673	-0.2345	0.823914
(2)T (L)*	120.669	19.80864	6.0917	0.001725
T (Q)	-4.655	29.76673	-0.1564	0.881853
(3)P (L)*	-357.982	19.80864	-18.0720	0.000010
P (Q)*	125.276	29.76673	4.2086	0.008420
1L by 2L	-0.040	25.86981	-0.0016	0.998820
1L by 3L	-0.026	25.86981	-0.0010	0.999231
2L by 3L	-29.547	25.86981	-1.1421	0.305119

p: significance probability. *: statistically significant effect.

The model which represents the Molecular Weight Number behavior is shown in the Equation (5).

$$MWN = 697.989 + 60.334 \cdot T - 178.991 \cdot P + 64.866 \cdot P^2 \quad (5)$$

It is necessary to do a variance test to confirm if the model found represents the response (MWN) behavior. It was calculated the F value. The test was done in equation (6) and (7).

- F Test:

$$F_{calculated} = \frac{MS_R}{MS_r} \gg F_{3,11}(95\%) = 3.59 \quad (6)$$

$$F_{calculated} = \frac{MS_R}{MS_r} = \frac{178430.268}{773.9} = 230.57 \checkmark \quad (7)$$

The F test was approved in this case too; it is possible to confirm that this model represents and predict the Molecular Weight Number behavior; in addition, the R square is 0.98435. Only the variable Temperature (2) has a linear effect significant and this term in Equation (5) is positive, so, to maximize this response (MWN) is necessary working in the highest studied level (+1.68). For the variable Pressure (3) as this one has its quadratic term positive, it is possible to find only a minimum value, deriving Equation (5) and doing it equal to zero. However, as the main objective in this stage is maximizing the Molecular Weight Number (MWN), it is necessary to observe Figure 6, because the maximum is located in some limited value (-1.68 or 1.68).

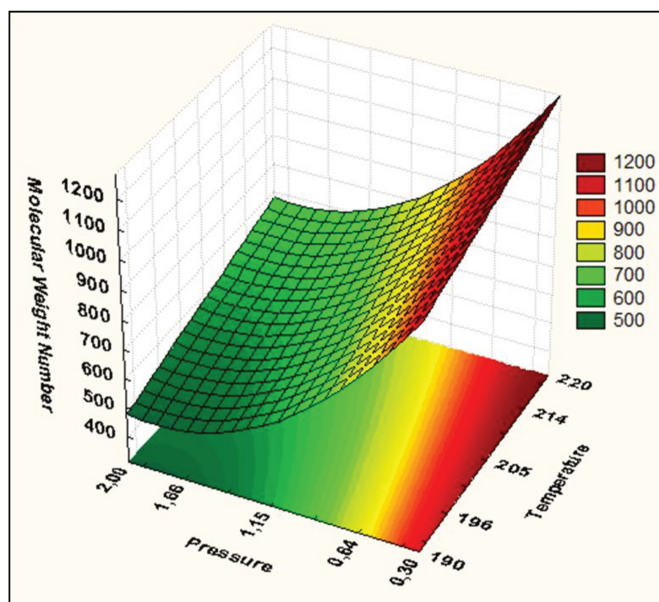

Figure 6. Response surface plot for Molecular Weight Number.

According with the Figure 6, the MWN achieves the maximum value when Pressure (3) is in the level (-1.68) and the Temperature (2) is in the superior studied level (+1.68). The values not coded are: Temperature (2) (220 °C), Pressure (3) (0.3 atm); the other analyzed variables (1) and (4) are not high significant.

To maximizing the both responses (PMF and MWN) in this stage process (oligomerization) is necessary operating under the following conditions:

- Feed Composition: 0.95 (95%)
- Temperature (2): 220 °C
- Pressure (3): 0.3 atm
- Water Recovery Column (4): 0.9999

3.2. LACTIDE REACTOR

3.2.1. Full design of experiments

For the lactide formation in the second batch reactor, the following variables were considered: Temperature (1), Pressure (2) and Catalyst (3); the responses studied were Lactide Mass Flow, Purity Lactide and Lactic acid Mass Flow. Table 9 shows the dependent and independent variables and their simulation values.

* Modelagem e simulação do processo de produção de PLA (poli-ácido láctico) obtido a partir de fontes renováveis para uso biomédico *

Table 9. Full design of experiments matrix 2^3 , variables and responses.

TESTS	T	P	C	LMF	PL	LAMF
1	-1	-1	-1	0.7408	0.9575	0.0208
2	-1	-1	+1	0.7405	0.9000	0.8291
3	-1	+1	-1	0.0724	0.0936	0.0021
4	-1	+1	+1	0.0724	0.0880	0.0021
5	+1	-1	-1	0.7397	0.9561	0.0226
6	+1	-1	+1	0.7519	0.9139	0.0007
7	+1	+1	-1	0.0856	0.1107	0.0019
8	+1	+1	+1	0.0856	0.1041	0.0019
9	0	0	0	0.0615	0.8544	0.0014

T: Temperature - P: Pressure - C: Catalyst
 LMF: Lactide Mass Flow - PL: Purity Lactide – LAMF: Lactic Acid Mass Flow

The values of the variable levels are listed in the Table 10.

Table 10. Variables and values.

VARIABLE	-1	0	1
Temperature [°C]	200	205	230
Pressure [torr]	5	382.5	760
Catalyst [kg/hr]	0.001	0.0255	0.05

In Table 11 is possible to observe that only the Pressure (2) has a significant effect for the lactide mass flow response. However, the curvature test is significant; as a result, a linear model will not represent the Lactide Mass Flow. In this time the confidence limit was of 90%, so the p values of significant effects are higher than 0.1. Also, it was used residual error in the statistic software.

Table 11. Effects and statistics data for Lactide Mass Flow.

FACTORS	Effect	Standard Error	t(1)	p
Mean/Interac.*	0,411105	0,001564	262,869	0,002422
Curvature*	-0,699242	0,009383	-74,518	0,008543
(1)T	0,009184	0,003128	2,936	0,208974
(2)P*	-0,664203	0,003128	-212,352	0,002998
(3)C	0,002952	0,003128	0,944	0,518457
1 by 2	0,004048	0,003128	1,294	0,418804
1 by 3	0,003128	0,003128	1,000	0,500000
2 by 3	-0,002952	0,003128	-0,944	0,518456

p: significance probability. *:statistically significant effect

On the other hand, the Purity Lactide is affected by the variables: Pressure (2) and Catalyst (3). Notwithstanding the curvature test is significant and it is better made a central composite analysis. Table 12 presents the variable effects over Purity Lactide (PL).

Table 12. Effects and statistics data for Purity Lactide.

FACTORS	Effect	Standard Error	t(1)	p
Mean/Interac.*	0,515472	0,002039	252,798	0,002518
Curvature*	0,677818	0,012234	55,403	0,011490
(1)T	0,011396	0,004078	2,794	0,218774
(2)P*	-0,832801	0,004078	-204,211	0,003117
(3)C*	-0,027946	0,004078	-6,853	0,092249
1 by 2	0,005197	0,004078	1,274	0,423593
1 by 3	0,003569	0,004078	0,875	0,542338
2 by 3	0,021864	0,004078	5,361	0,117393

p: significance probability. *: statistically significant effect.

Any variable effects over Lactic Acid Mass Flow were not statistically significant, as is observed in Table 13.

Table 13. Effects and statistics data for Lactic Acid Mass Flow.

FACTORS	Effect	Standard Error	t(1)	p
Mean/Interac.	0,110146	0,103761	1,06153	0,481003
Curvature	-0,217476	0,622566	-0,34932	0,786051
(1)T	-0,206754	0,207522	-0,99630	0,501180
(2)P	-0,216307	0,207522	-1,04233	0,486807
(3)C	0,196589	0,207522	0,94732	0,517219
1 by 2	0,206586	0,207522	0,99549	0,501439
1 by 3	-0,207522	0,207522	-1,00000	0,500000
2 by 3	-0,196610	0,207522	-0,94742	0,517185

p: significance probability. *: statistically significant effect.

3.2.2. Central composite analysis of experiments

As in the full design of experiments 2^3 the curvature tests were significant, it was done a central composite analysis of experiments 2^3 . The same variables were studied. The matrix of his analysis is in Table 14.

Table 14. Central composite analysis of experiment matrix 2^3 , variables and responses.

TESTS	T	P	C	LMF	PL	LAMF
1	-1	-1	-1	0.0914	0.1167	0.0007
2	-1	-1	+1	0.0898	0.1105	0.0008
3	-1	+1	-1	0.0750	0.0958	0.0020
4	-1	+1	+1	0.0750	0.0923	0.0020
5	+1	-1	-1	0.7582	0.9673	0.0000
6	+1	-1	+1	0.7589	0.9326	0.0000
7	+1	+1	-1	0.0829	0.1058	0.0019
8	+1	+1	+1	0.0829	0.1020	0.0019
9	+1.68	0	0	0.0953	0.1194	0.0011
10	-1.68	0	0	0.0724	0.0907	0.0021
11	0	+1.68	0	0.0790	0.0989	0.0020
12	0	-1.68	0	0.7517	0.9418	0.0016
13	0	0	+1.68	0.0795	0.0967	0.0019
14	0	0	-1.68	0.0806	0.1042	0.0017
15	0	0	0	0.0801	0.1003	0.0018

T: Temperature - P: Pressure – C: Catalyst

LMF: Lactide Mass Flow - PL: Purity Lactide – LAMF: Lactic Acid Mass Flow

The values of the variable levels are listed in Table 15.

Table 15. Variables and values.

VARIABLE	-1.68	-1	0	1	1.68
Temperature [°C]	200	206.07	215	223.93	230
Pressure [torr]	5	157.8	382.5	607.2	760
Catalyst [kg/hr]	0.001	0.0109	0.0255	0.0401	0.05

Figure 7 and Table 16 let see the variable effects which are significant over Lactide Mass Flow. These variables are the following: linear effect of Temperature (1), the both effects of Pressure (2) and the linear interaction between them, (1) by (2).

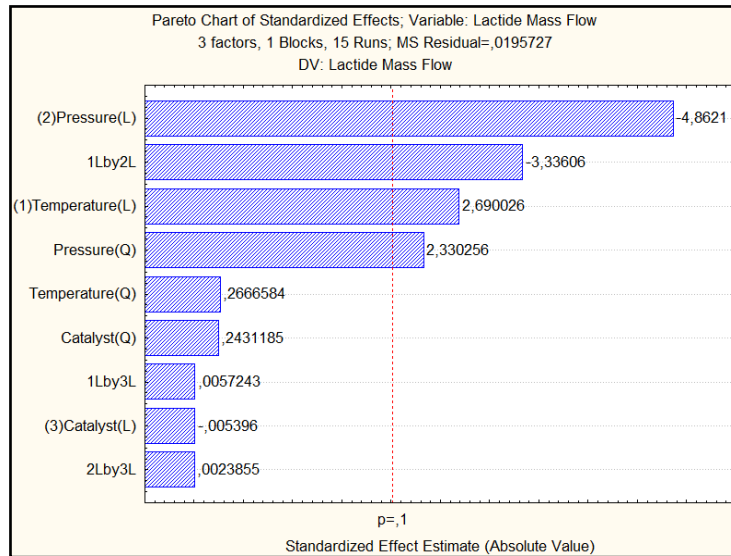

Figure 7. Pareto Chart for Lactide Mass Flow.

Table 16. Effects and statistics data for Lactide Mass Flow.

FACTORS	Effect	Standard Error	t(1)	p
Mean/Interac.	0,069825	0,139027	0,50224	0,636830
(1)T (L)*	0,203765	0,075748	2,69003	0,043297
T (Q)	0,030353	0,113828	0,26666	0,800380
(2)P (L)*	-0,368295	0,075748	-4,86210	0,004625
P (Q)*	0,265248	0,113828	2,33026	0,067190
(3)C (L)	-0,000409	0,075748	-0,00540	0,995903
C (Q)	0,027674	0,113828	0,24312	0,817573
1L by 2L *	-0,330024	0,098926	-3,33606	0,020641
1L by 3L	0,000566	0,098926	0,00572	0,995654
2L by 3L	0,000236	0,098926	0,00239	0,998189

p: significance probability. *: statistically significant effect.

The model which represents the Lactide Mass Flow behavior is shown in the Equation (8) and their coefficient are taken of the Statistic 7.0.

$$LMF = 0.106325 + 0.101882 \cdot T - 0.184147 \cdot P - 0.121512 \cdot P^2 - 0.165012 \cdot T \cdot P \quad (8)$$

- F Test:

$$F_{calculated} = \frac{MS_R}{MS_r} \gg F_{4,10}(90\%) = 2.61 \quad (9)$$

$$F_{calculated} = \frac{MS_R}{MS_r} = \frac{0.24806412}{0.009945} = 24.94 \checkmark \quad (10)$$

The F test was approved and the R square is 0.90859. For that reason, this model can represent and predict the Lactide Mass Flow behavior. However, to know the best values of Pressure (2) and Temperature (1), which achieve maximum values of Lactide Mass Flow, it is necessary observed the response surface in the Figure 8.

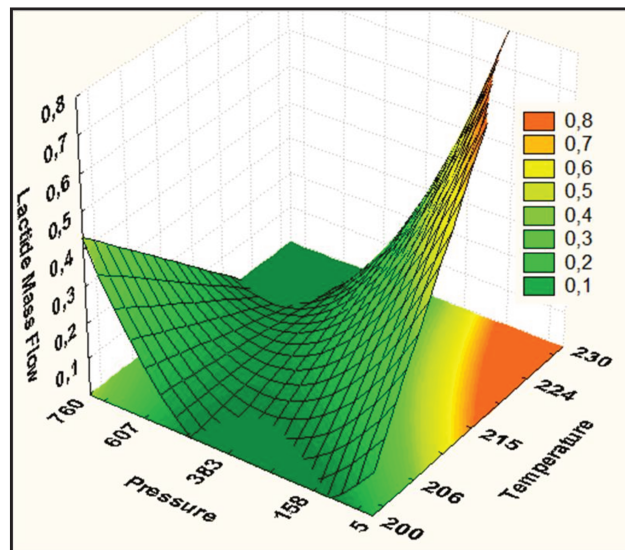

Figure 8. Response surface plot for Lactide Mass Flow.

In the lactide formation, when are used lower levels of Pressure (2) and higher levels of Temperature (1), the Lactide Mass Flow is maximized. The variable values not encoded are: Temperature (1) (230 °C) and Pressure (2) (5 torr). The Catalyst (3) effects are not significant over this response (LMF).

Reactants, byproducts and products purity is very important in this studied (Martinez et al. 2011), for this reason is important study the behavior of the Purity Lactide (PL). Figure 9 and Table 17 show the variable effects which are significant for this response (PL). The both effects of Pressure (2), linear effect of Temperature (1) and the interaction between them are significant over the Purity Lactide.

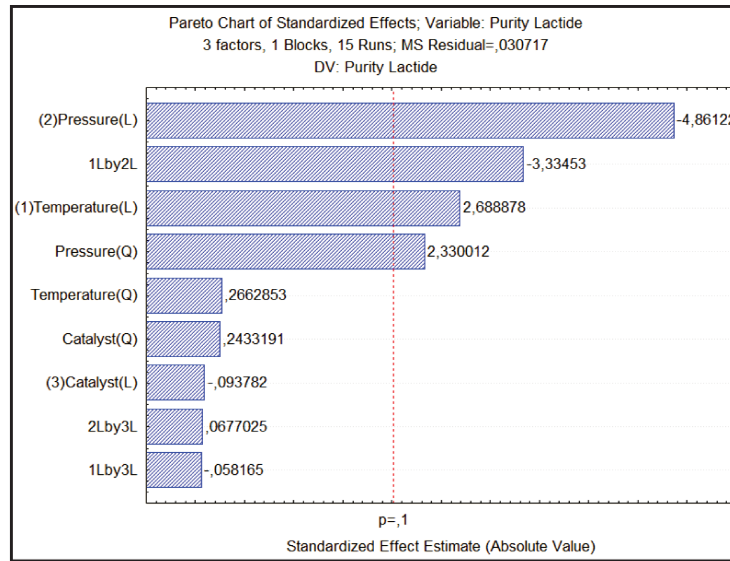

Figure 9. Pareto Chart for Purity Lactide.

Table 17. Effects and statistics data for Purity Lactide.

FACTORS	Effect	Standard Error	t(5)	p
Mean/Interac.	0,087499	0,174165	0,50239	0,636732
(1)T (L)*	0,255156	0,094893	2,68888	0,043357
T (Q)	0,037972	0,142598	0,26629	0,800652
(2)P (L)*	-0,461297	0,094893	-4,86122	0,004628
P (Q)*	0,332254	0,142598	2,33001	0,067210
(3)C (L)	-0,008899	0,094893	-0,09378	0,928924
C (Q)	0,034697	0,142598	0,24332	0,817426
1L by 2L*	-0,413246	0,123929	-3,33453	0,020676
1L by 3L	-0,007208	0,123929	-0,05816	0,955871
2L by 3L	0,008390	0,123929	0,06770	0,948646

p: significance probability. *: statistically significant effect.

The model which represents the Lactide Purity behavior is shown in the Equation (11).

$$PL = 0.133209 + 0.127578 \cdot T - 0.230648 \cdot P - 0.152211 \cdot P^2 - 0.206623 \cdot T \cdot P \quad (11)$$

- F Test:

$$F_{calculated} = \frac{MS_R}{MS_r} \gg F_{4,10}(90\%) = 2.61 \quad (12)$$

$$F_{\text{calculated}} = \frac{MS_R}{MS_r} = \frac{0.3891025}{0.015658} = 24.85 \checkmark \quad (13)$$

The test F was approved in this case too, so, this model can represent and predict the Molecular Weight Number behavior; in addition the R square is 0.98435. However, to know the variable values where is maximize this response, it is necessary see the response surface plot (Figure 10).

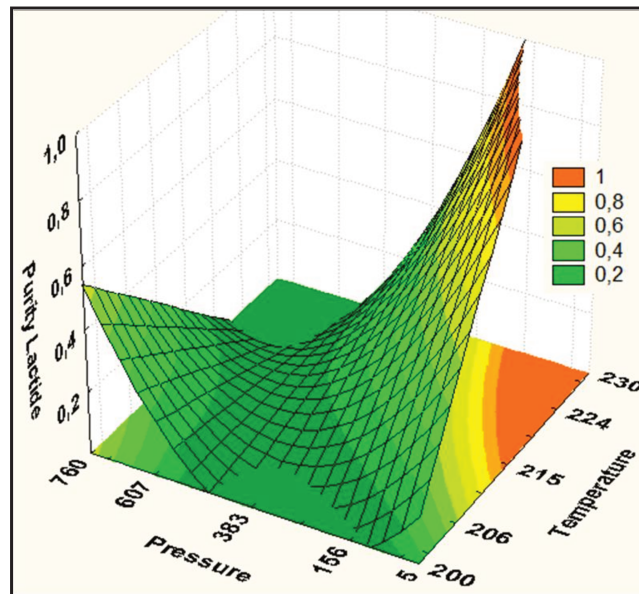

Figure 10. Response surface plot for Purity Lactide.

In accordance with Figure 10, the Purity Lactide achieves the maximum value when are used lower levels of Pressure (2) (-1.68) and higher levels of Temperature (1) (+1.68), is the same behavior of Lactide Mass Flow. The variable values not encoded are: Temperature (1) (230 °C) and Pressure (2) (5 torr). In this time, the Catalyst (3) effects are not significant over this response (PL).

In the synthesis of high molecular weight PLA is important has a control over the Purity Lactide in the last stage, therefore, are studied the water and the lactic acid Mass Flow in the second reactor (LACTID-R). However, especially in this case, the water is removed in the second process column which is found in the Figure 1, before the third reactor. For that reason, the last studied response in this stage is the Lactic Acid Mass Flow to know when this variable can be minimized. According with Figure 11 and Table 18, this response is only affected by the linear variable Pressure (2) for a confidence limit of 90%.

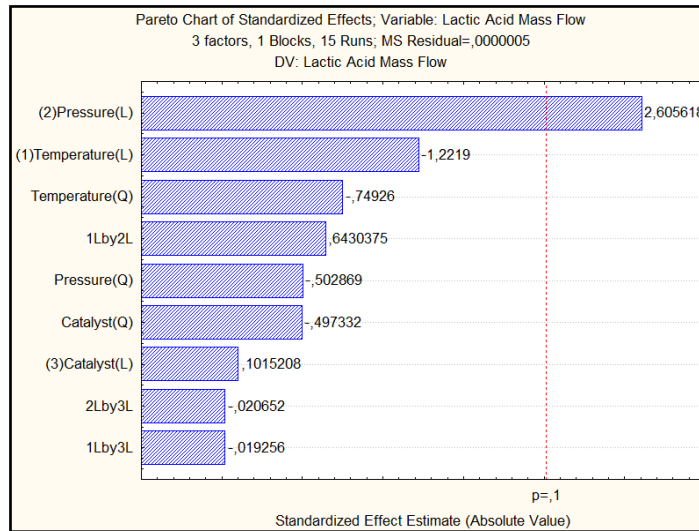

Figure 11. Pareto Chart for Purity Lactide.

Table 18. Effects and statistics data for Purity Lactide.

FACTORS	Effect	Standard Error	t(5)	p
Mean/Interac.*	0,001916	0,000720	2,66141	0,044808
(1)T (L)	-0,000479	0,000392	-1,22190	0,276204
T (Q)	-0,000442	0,000589	-0,74926	0,487432
(2)P (L)*	0,001022	0,000392	2,60562	0,047923
P (Q)	-0,000296	0,000589	-0,50287	0,636419
(3)C (L)	0,000040	0,000392	0,10152	0,923083
C (Q)	-0,000293	0,000589	-0,49733	0,640050
1L by 2L	0,000329	0,000512	0,64304	0,548524
1L by 3L	-0,000010	0,000512	-0,01926	0,985381
2L by 3L	-0,000011	0,000512	-0,02065	0,984322

p: significance probability. *: statistically significant effect.

The model which represents the Lactic Acid Mass Flow behavior is shown in the Equation (14).

$$LAMF = 0.001447 + 0.000511 \cdot P \quad (14)$$

- Test F:

$$F_{calculated} = \frac{MS_R}{MS_r} \gg F_{1,13}(90\%) = 3.14 \quad (15)$$

* *Modelagem e simulação do processo de produção de PLA (poli-ácido láctico) obtido a partir de fontes renováveis para uso biomédico* *

$$F_{calculated} = \frac{MS_R}{MS_r} = \frac{3.5618E - 06}{3.0194E - 07} = 11.80 \checkmark \quad (16)$$

The test F was approved in this case also, but it is possible that this model does not represent and predict the Molecular Weight Number behavior, because the F calculated is not too much higher than the founded in the literature; in addition the R square is 0.47573. However, it is possible know the Lactic Mass Flow behavior using the response surface plot (Figure12).

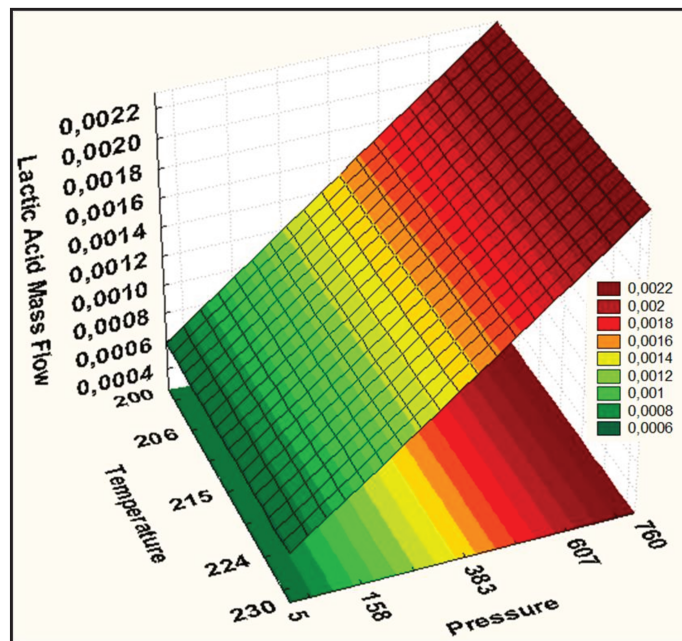

Figure 12. Response surface plot for Lactic Acid Mass Flow.

According with the Figure 12, low values of Pressure (3) favor lower values of Lactic Acid Mass Flow. To maximize the first and second responses (LMF and PL) and minimizing the Lactic Acid Mass Flow in this stage process (lactide formation) is necessary operating under the following conditions:

- Temperature (1): 230 °C
- Pressure (2): 5 torr
- Catalyst (3): 0.005 kg/hr

3.3. POLYMERIZATION REACTOR

3.3.1. Full design of experiment

The last stage is the synthesis of high molecular PLA; in this part of the process was done the same design of experiments which use two-level factors and four variables as in the first stage. Table 19 shows the tests done with their independent (Catalyst, Temperature, Pressure and Water Recovery Column) and the dependent variables (PLA Mass Flow, PLA Purity, Molecular Weight Number).

Table 19. Matrix of experiments full design 2⁴, variables and responses.

TESTS	C	T	P	WRC	PMF	PP	MWN
1	-1	-1	-1	-1	0.6891	0.9277	7861.802
2	-1	-1	-1	+1	0.6868	0.9265	87110.525
3	-1	-1	+1	-1	0.6891	0.9277	7861.802
4	-1	-1	+1	+1	0.6868	0.9265	87110.525
5	-1	+1	-1	-1	0.6615	0.8904	7549.842
6	-1	+1	-1	+1	0.6588	0.8886	83556.879
7	-1	+1	+1	-1	0.6615	0.8904	7549.842
8	-1	+1	+1	+1	0.6588	0.8886	83555.575
9	+1	-1	-1	-1	0.6891	0.8703	7861.687
10	+1	-1	-1	+1	0.6868	0.8690	87110.862
11	+1	-1	+1	-1	0.6891	0.8703	7861.687
12	+1	-1	+1	+1	0.6868	0.8690	87110.862
13	+1	+1	-1	-1	0.6615	0.8353	7549.758
14	+1	+1	-1	+1	0.6588	0.8335	83554.177
15	+1	+1	+1	-1	0.6615	0.8353	7549.758
16	+1	+1	+1	+1	0.6588	0.8335	83578.720
17	0	0	0	0	0.6744	0.8798	14026.234

C: Catalyst - T: Temperature - P: Pressure - WRC: Water Recovery Column
 PMF: PLA Mass Flow - PP: Purity PLA - MWN: Molecular Weight Number

The values of the variable levels are listed in the Table 20.

Table 20. Variables and values.

VARIABLE	-1	0	1
Catalyst [kg/hr]	0.001	0.0255	0.05
Temperature [°C]	140	170	200
Pressure [atm]	0.3	1.15	2
Water Recovery Column	0.9	0.95	0.9999

The first analyzed response variable was the PLA Mass Flow. Table 21 presents the effect value of each studied variable over this response, as well as the effects generated by the interaction between them. For this response (PMF), the variables statically significant for a confidence limit of 95%, are Water Recovery Column (1) and Temperature (3). For this response the curvature test was significant, thus, the linear model is not predicted.

Table 21. Effects and statistics data for PLA Mass Flow.

FACTORS	Effect	Standard Error	t(1)	p
Mean/Interac.*	0.674040	1.25E-08	53881281	0.000000
Curvature*	0.000773	1.03E-07	7492	0.000085
(1)WRC*	-0.002483	2.50E-08	-99242	0.000006
(2)P	0.000000	2.50E-08	-1	0.533721
(3)T*	-0.027869	2.50E-08	-1113905	0.000001
(4)C	0.000000	2.50E-08	1	0.442527
1 by 2	0.000000	2.50E-08	-1	0.533721
1 by 3*	-0.000219	2.50E-08	-8744	0.000073
1 by 4	0.000000	2.50E-08	-3	0.218533
2 by 3	0.000000	2.50E-08	-1	0.533721
2 by 4	0.000000	2.50E-08	-1	0.500247
3 by 4	0.000000	2.50E-08	-1	0.500247
1*2*3	0.000000	2.50E-08	-1	0.533721
1*2*4	0.000000	2.50E-08	-1	0.500247
1*3*4	0.000000	2.50E-08	0	0.874429
2*3*4	0.000000	2.50E-08	-1	0.500247

p: significance probability. *: statistically significant effect.

The second analyzed response in this process stage was the Purity PLA. This variable was not affected significantly by the variable Pressure (2) and their interactions with other variables. The curvature test is also significant, so, it cannot represent by a linear model. That can be seen in Table 22.

Table 22. Effects and statistics data for Purity PLA.

FACTORS	Effect	Standard Error	t(1)	p
Mean/Interac.*	0.880157	1.69E-08	52151729	0.000000
Curvature*	-0.000787	1.39E-07	-5653	0.000113
(1)WRC*	-0.001554	3.38E-08	-46029	0.000014
(2)P	0.000000	3.38E-08	-1	0.579201
(3)T*	-0.036392	3.38E-08	-1078159	0.000001
(4)C*	-0.056258	3.38E-08	-1666732	0.000000
1 by 2	0.000000	3.38E-08	-1	0.579201
1 by 3*	-0.000321	3.38E-08	-9497	0.000067
1 by 4*	-0.000004	3.38E-08	-127	0.005002
2 by 3	0.000000	3.38E-08	-1	0.579201
2 by 4	0.000000	3.38E-08	-1	0.500035
3 by 4*	0.001163	3.38E-08	34457	0.000018
1*2*3	0.000000	3.38E-08	-1	0.579201
1*2*4	0.000000	3.38E-08	-1	0.500035
1*3*4*	0.000011	3.38E-08	336	0.001894
2*3*4	0.000000	3.38E-08	-1	0.500035

p: significance probability. *: statistically significant effect.

The molecular weight of PLA can be used to determine its applicability in certain biomedical applications, (Kricheldorf and Lee, 1995). For this reason this variable is an analyzed response. From Table 23 is observed that the variables Column Ratio Reflux (3) and Temperature (3) and the interaction between them have significantly effects that affect the MWN.

Table 23. Effects and statistics data for Molecular Weight Number.

FACTORS	Effect	Standard Error	t(1)	p
Mean/Interac.*	46520.89	1.615438	28797.70	0.000022
Curvature*	-64989.3	13.32124	-4878.62	0.000130
(1)WRC*	77630.24	3.230876	24027.62	0.000026
(2)P	2.90	3.230876	0.90	0.533785
(3)T	-1930.65	3.230876	-597.56	0.001065
(4)C	2.59	3.230876	0.80	0.569851
1 by 2	2.90	3.230876	0.90	0.533785
1 by 3*	-1618.71	3.230876	-501.01	0.001271
1 by 4	2.69	3.230876	0.83	0.558089
2 by 3	2.90	3.230876	0.90	0.533785
2 by 4	3.23	3.230876	1.00	0.500000
3 by 4	2.48	3.230876	0.77	0.583359
1*2*3	2.90	3.230876	0.90	0.533785
1*2*4	3.23	3.230876	1.00	0.500000
1*3*4	2.46	3.230876	0.76	0.585275
2*3*4	3.23	3.230876	1.00	0.500000

p: significance probability. *: statistically significant effect.

3.3.2. Central composite analysis of experiments

In the full design of experiments 2⁴, the curvature tests were significant for all responses; it was done a central composite analysis of experiments 2³. The variable Pressure is not analyzed in this time because its effects over all responses were not significant. The matrix of his analysis is in the Table 24.

Table 24. Central composite analysis of experiment matrix 2^3 , variables and responses.

TESTS	C	T	WRC	PMF	PP	MWN
1	-1	-1	-1	0.6833	0.9081	9522.96
2	-1	-1	+1	0.6819	0.9073	28125.44
3	-1	+1	-1	0.6668	0.8861	9294.63
4	-1	+1	+1	0.6652	0.8851	27439.41
5	+1	-1	-1	0.6833	0.8742	9522.96
6	+1	-1	+1	0.6819	0.8734	28125.44
7	+1	+1	-1	0.6668	0.8530	9294.63
8	+1	+1	+1	0.6652	0.8520	27439.41
9	+1.68	0	0	0.6744	0.8525	14026.23
10	-1.68	0	0	0.6744	0.9088	14026.29
11	0	+1.68	0	0.6601	0.8611	13731.15
12	0	-1.68	0	0.6880	0.8975	14306.14
13	0	0	+1.68	0.6732	0.8790	85380.32
14	0	0	-1.68	0.6757	0.8805	7709.69
15	0	0	0	0.6744	0.8798	14026.23

T: Temperature – WRC: Water Recovery Column – C: Catalyst
PMF: PLA Mass Flow – PP: Purity PLA – MWN: Molecular Weight Number

The values of the variable levels are listed in the Table 25.

Table 25. Variables and values.

VARIABLE	-1.68	-1	0	1	1.68
Catalyst [kg/hr]	0.001	0.0109	0.0255	0.0401	0.05
Temperature [°C]	140	152.14	170	187.86	200
Water Recovery Column	0.9	0.9202	0.95	0.9797	0.9999

For PLA Mass Flow the following effects are significant: linear effect of Water Recovery Column (3), linear and the quadratic effect of Temperature (2) and the interaction between these variables. These can be observed in Figure 13 and Table 26.

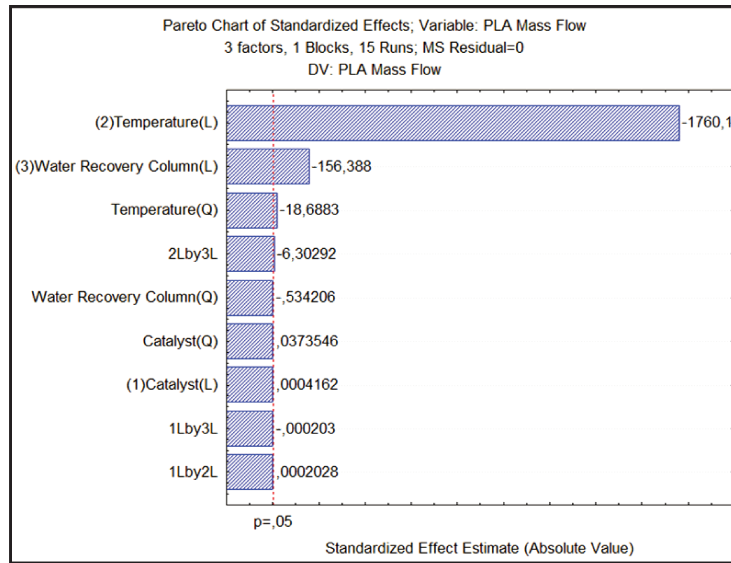

Figure 13. Pareto Chart for PLA Mass Flow.

Table 26. Effects and statistics data for PLA Mass Flow.

FACTORS	Effect	Standard Error	t(1)	p
Mean/Interac.*	0.674426	0.000017	38932.23	0.000000
(1)C (L)	0.000000	0.000009	0.00	0.999684
C (Q)	0.000001	0.000014	0.04	0.971648
(2)T (L)*	-0.016613	0.000009	-1760.16	0.000000
T (Q)*	-0.000265	0.000014	-18.69	0.000008
(3)WRC (L)*	-0.001476	0.000009	-156.39	0.000000
WRC (Q)	-0.000008	0.000014	-0.53	0.616087
1L by 2L	0.000000	0.000012	0.00	0.999846
1L by 3L	0.000000	0.000012	0.00	0.999846
2L by 3L*	-0.000078	0.000012	-6.30	0.001479

p: significance probability. *: statistically significant effect.

The model which represents the PLA Mass Flow behavior is shown in the Equation (17) and their coefficients is taken of the Statistic 7.0.

$$PMF = 0.674421 - 0.008307 \cdot T - 0.000131 \cdot T^2 - 0.000738 \cdot (WRC) - 0.000039 \cdot T \cdot (WRC) \quad (17)$$

- F Test:

$$F_{calculated} = \frac{MS_R}{MS_r} >> F_{4,10}(95\%) = 3.48 \quad (18)$$

$$F_{calculated} = \frac{MS_R}{MS_r} = \frac{0.000237}{1.67E-10} = 1417929.01 \checkmark \quad (19)$$

The F test was approved, and it is possible to confirm that this model represents and predict the Lactide Mass Flow behavior. Besides that, the R square is 1. Since the main objective is to synthesize PLA, it is try to maximize this response (PMF). To find the variable values which maximize the response, it is analyzed the model found. For the variable Temperature (2), as this one has its quadratic term negative, it is possible find a maximum value, deriving Equation (20) respect to the WRC and doing it equal to zero.

$$\frac{\partial(PMF)}{\partial(WRC)} = -0.000738 - 0.000039 \cdot T = 0 \quad T = -1.8923 \quad (20)$$

When the value of Temperature (2) is -1.8923, the response (PMF) achieves its maximum value, however the limit in this study is -1.68, so, this is the temperature value which PLA Mass Flow achieves the maximum value. The Water Recovery Column (3) behavior is linear and its coefficients in the model are negative, for this reason to maximize this response (PMF) is better worked in the lowest level (-1.68). The values not coded are: Temperature (2) (140°C) and Water Recovery Column (3) (0.9); the Catalyst (1) is not high significant to this response in the studied range. In Figure 14 (Response Surface), it is possible shows the behavior of the PLA Mass Flow and confirming the variable values which maximize this response (PMF).

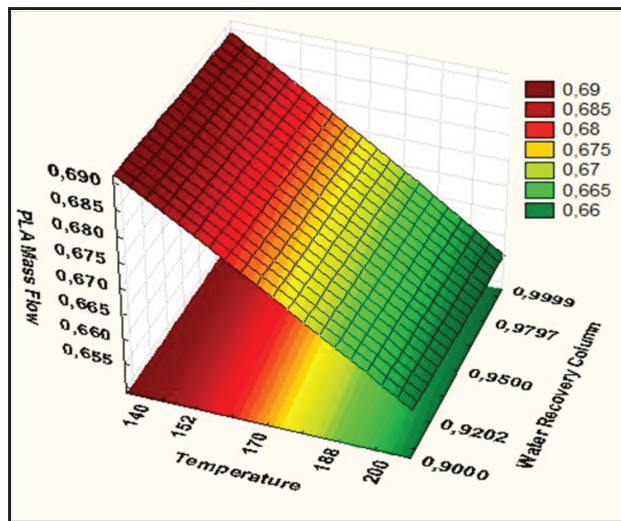

Figure 14. Response surface plot for PLA Mass Flow.

Other response in the final process stage is the Purity PLA (PP) because it is important to produce the poly (lactic acid) the most purity possible, to prevent the early hydrolysis of the final product and to avoid other purification process. In this response only the quadratic effect of Water Recovery Column (3) and the interaction (1) by (3) are not significant. That can be seen in the Figure 15 and the Table 27.

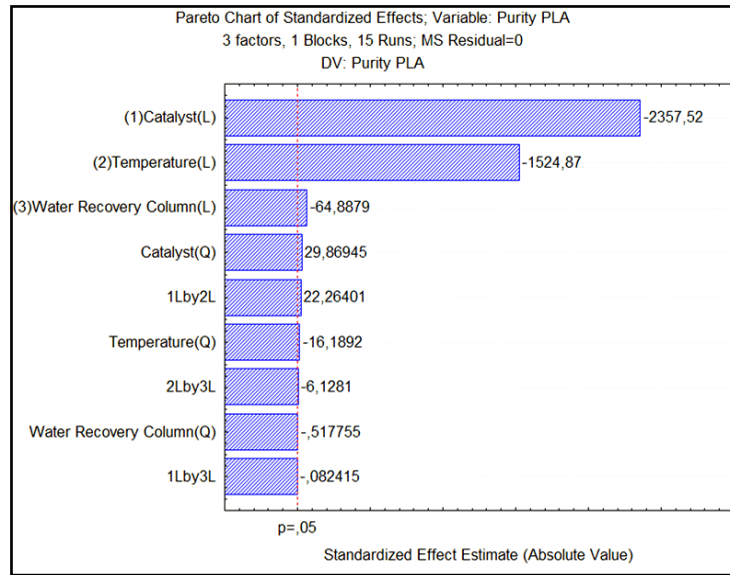

Figure 15. Pareto Chart for PurityPLA.

Table 27. Effects and statistics data for Purity PLA.

FACTORS	Effect	Standard Error	t(5)	p
Mean/Interac.*	0.879764	0.000026	33720.58	0.000000
(1)C (L)*	-0.033512	0.000014	-2357.52	0.000000
C (Q)*	0.000638	0.000021	29.87	0.000001
(2)T (L)*	-0.021676	0.000014	-1524.87	0.000000
T (Q)*	-0.000346	0.000021	-16.19	0.000016
(3)WRC (L)*	-0.000922	0.000014	-64.89	0.000000
WRC (Q)	-0.000011	0.000021	-0.52	0.626714
1L by 2L*	0.000413	0.000019	22.26	0.000003
1L by 3L	-0.000002	0.000019	-0.08	0.937514
2L by 3L*	-0.000114	0.000019	-6.13	0.001679

p: significance probability.

*: statistically significant effect.

The model which represents the Purity PLA behavior is shown in the Equation (21).

$$PP = 0.879752 - 0.016756 \cdot C + 0.00322 \cdot C^2 - 0.010838 \cdot T - 0.000169 \cdot T^2 - 0.000461 \cdot (WRC) + 0.00207 \cdot C \cdot T - 0.000057 \cdot T \cdot (WRC) \quad (21)$$

- F Test:

$$F_{calculated} = \frac{MS_R}{MS_r} \gg F_{7,7} (95\%) = 3.79 \quad (22)$$

$$F_{calculated} = \frac{MS_R}{MS_r} = \frac{0.000777}{5.19E-10} = 1495918.70 \checkmark \quad (23)$$

The F test was approved in this case also. It is possible confirm that this model represents and predict the Purity PLA behavior, in addition the R square is 1. How the variable Temperature (2) has a quadratic behavior and its coefficient are negative, it is possible calculated the maximum Temperature (2) value deriving the model found for PP respect the Water Recovery Column (3), this is represented in the Equation (24).

$$\frac{\partial(PP)}{\partial(WRC)} = -0.000461 - 0.000057 \cdot T = 0 \quad T = -8.088 \quad (24)$$

The temperature value is outside of the studied range, for these reason we take the limit (-1.68) how the point where is achieved the maximum response (PP) value. The variable Catalyst (1) presents a quadratic behavior over the Purity PLA, but its coefficient is positive, having a minimum value. However, as the main is maximizing the Purity PLA, it is necessary to observe in Figure 16 and Figure 17, because the maximum is located in some limited value (-1.68 or 1.68). The variable Water Recovery Column (3) only has the linear effect how significant and this term in the Equation (21) is negative to maximize this response (PP) is necessary worked in the lowest studied level (-1.68).

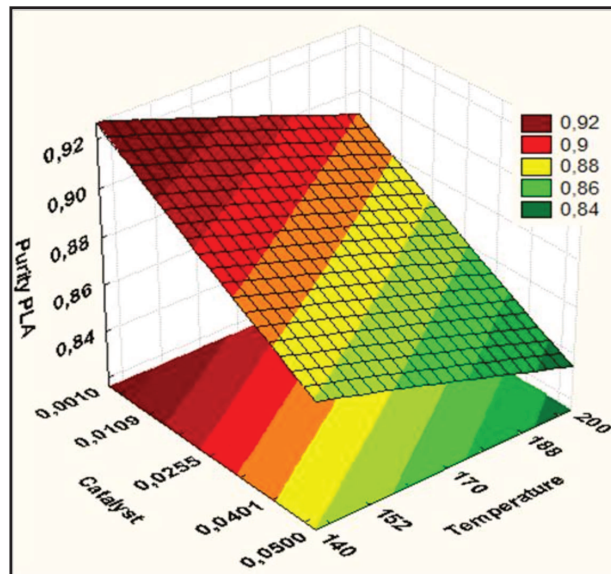

Figure 16. Response surface plot for PP.

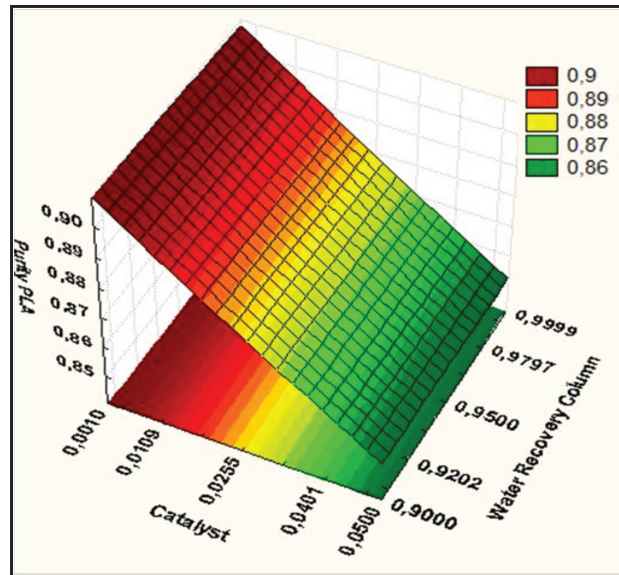

Figure 17. Response surface plot for PP.

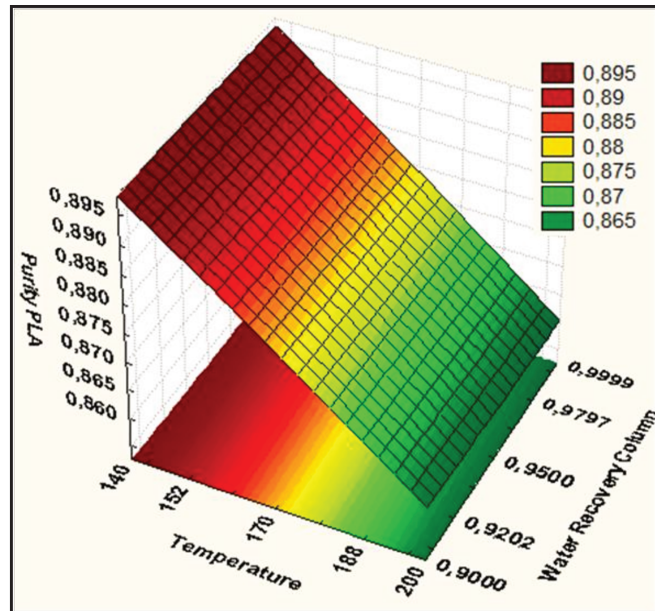

Figure 18. Response surface plot for PP.

According with Figure 16a and Figure 16b, Catalyst (1) achieves the maximum value in the level (-1.68). Figures 16, 17 and 18 confirm the values that must be used to minimize the Purity PLA (PP) (-1.68). The values not coded are: Temperature (2) (140°C) and the Catalyst (1) (0.001kg/hr).

The final Response analyzed was the PLA Molecular Weight Number (MWN); this response was studied because the application of this polymer in the medical field depends of properties such as Molecular Weight Number (Kricheldorf, H. R. and Lee, S. R.). Only the linear effect of Water Recovery Column (3) is significant over this response (MWN) that is represented in Figure 19 and Table 28.

* Modelagem e simulação do processo de produção de PLA (poli-ácido láctico) obtido a partir de fontes renováveis para uso biomédico *

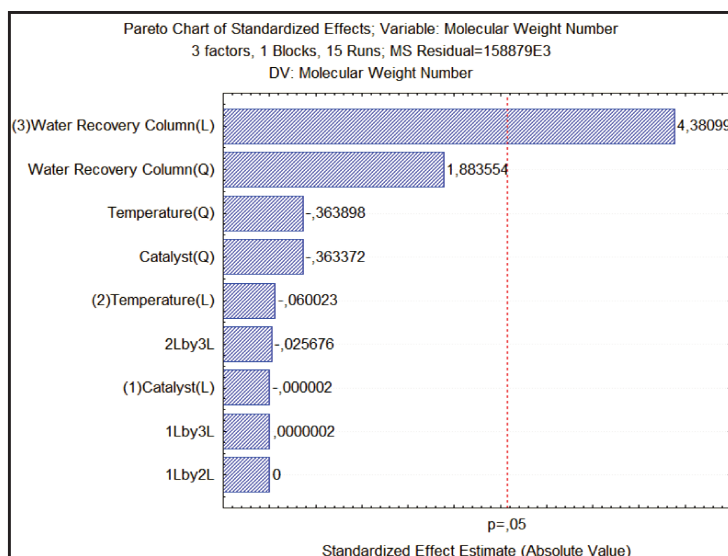

Figure 19. Pareto Chart for Molecular Weight Number.

Table 28. Effects and statistics data for Molecular Weight Number.

FACTORS	Effect	Standard Error	t(5)	p
Mean/Interac.	15404.61	12525.83	1.229828	0.273468
(1)C (L)	-0.02	6824.64	-0.000002	0.999998
C (Q)	-3726.56	10255.49	-0.363372	0.731185
(2)T (L)	-409.64	6824.64	-0.060023	0.954463
T (Q)	-3731.95	10255.49	-0.363898	0.730815
(3)WRC (L)*	29898.74	6824.64	4.380997	0.007148
WRC (Q)	19316.77	10255.49	1.883554	0.118335
1L by 2L	0.00	8912.89	0.000000	1.000000
1L by 3L	0.00	8912.89	0.000000	1.000000
2L by 3L	-228.85	8912.89	-0.025676	0.980509

p: significance probability. *: statistically significant effect.

When the effects of interaction between the studied variables are ignored the quadratic effect of Water Recovery Column (3) and the mean, become significant, because the degrees of freedom increase. The model which represents the Molecular Weight Number behavior is shown in the Equation (26).

$$MWN = 10713.04 + 29898.74 \cdot (WRC) + 22173.34(WRC)^2 \quad (25)$$

- F Test:

$$F_{calculated} = \frac{MS_R}{MS_r} \gg F_{2,12}(95\%) = 3.89 \quad (26)$$

$$F_{\text{calculated}} = \frac{MS_R}{MS_r} = \frac{2232671706}{6.841652E+7} = 32.63 \checkmark \quad (27)$$

The F test was approved in this case also, it is possible that this model represents and predicts the Molecular Weight Number behavior; in addition the R square is 0.84469. However, the objective is to know the Molecular Weight Number behavior, therefore, it is necessary to observe the response surface plot in Figure 20, to understand the response behavior.

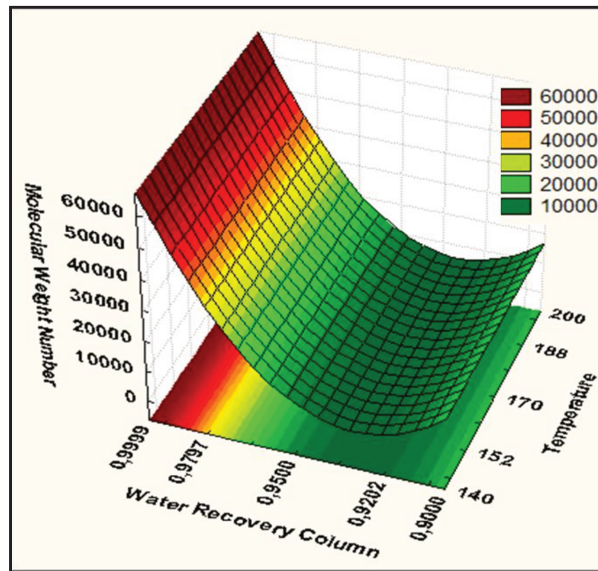

Figure 20. Response surface plot for Molecular Weight Number.

According with Figure 20, the Molecular Weight Number achieves the maximum value when the Water Recovery Column (1) is in the level (+1.68). The values not coded are: Temperature (2) (140°C), Pressure (3) (0.3 atm) and Water Recovery Column (0.9999).

To maximize the first and second responses (PMF and PP) is necessary operating under the following conditions:

- Catalyst (1): 0.005 kg/hr
- Temperature (2): 140 °C
- Pressure (3): any one
- Water Recovery Column (4): 0.9

The Molecular Weight Number (MWN) value depends of the polymer application. If it is necessary a polymer with high MWN, it must work with a Water Recovery Column (4) too high. But if it is required a polymer with low MWN, it is necessary reduce o WRC (4) value.

4. CONCLUSIONS

PLA batch synthesis process was carried out in three stages: oligomeration, lactide formation and polymerization. In the first stage, it was found the variables which have most influence over the PLA Mass Flow (PMF) and Molecular Weight Number (MWN). For the PMF in the OLIG-R reactor, Feed Composition (FC) and Pressure (P) were the variables with significant effects over this response. By the other hand, the variable effects of Pressure (P) and Temperature (T) were more significant over the MWN, than the others. In this stage for the studied range, the Water Recovery Column (WRC) effects were not influence in any process response. The response behaviors were evaluated and it was found a statistic quadratic models which represent and predict this behaviors.

For the second reactor (LACTID-R), it was found the variables which have most influence over the Lactide Mass Flow (LMF), Purity Lactide (PL) and Lactic Acid Mass Flow (LAMF). For the LMF, Temperature (FC) and Pressure (P) were significant effects over this response. Furthermore, the variable effects of Pressure (C) were not significant over any response. The response behaviors were evaluated and it was found a statistic quadratic models which were not much represented and predicted.

For the PLA polymerization (last stage), it was found that the variables that most influenced the Purity of PLA (PP), PLA Mass Flow (PMF) and Molecular Weight Number (MWN) of PLA-R reactor were: Water Recovery Column (WRC), Temperature (T) and Catalyst (C). The PMF and PP responses were influenced more significant by Temperature (T) and Water recovery Column (WRC); the PP was affect by Catalyst (C) too. The MWN was only influence by the Water Recovery Column. The effects of Pressure (P) were not significant over any response in this stage. Quadratics models were found to predict and represent the response behaviors.

REFERENCES

AURAS, R. A., LIM, L. T., SELKE, S. E. M., and TSUJI, H. (2010). Poly(Lactic Acid) : Synthesis, Structures, Properties, Processing, and Applications. New Jersey: John Wiley & Sons, Inc.

HENTON, D. E. GRUBER, P., LUNT, J. and RANDALL, J. (2005). Polylactic Acid Technology. Natural Fibers, Biopolymers and Biocomposites, A. K. Mohanty (Editors), CRC Press, p.528-569.

KRICHELDORF, H. R. and LEE, S. R. (1995). Poly lactones: 32. High-molecular-weight polylactides by ring-opening polymerization with dibutylmagnesium or butylmagnesium chloride, Polymer, v. 36, n. 15, p. 2995-3003.

LASPRILLA, A. J. R., MARTINEZ, G. A. R., LUNELLI, B. H., JARDINI, A. L., MACIEL FILHO, R. (2011). Poly-lactic acid synthesis for application in biomedical devices — A review, Biotechnology Advances, Article in Press, Corrected Proof.

MARTINEZ, G. A. R., LASPRILLA, A. J. R., LUNELLI, B. H., JARDINI, A. L., MACIEL FILHO, R. (2011). Modeling and Simulation of Poly (Lactic Acid) Synthesis from Renewable Feedstock for Application in Biomedical Devices, Computer Aided Chemical Engineering, v. 29, p. 346-350.

MIKOS, A. G. and TEMENOFF, J. S. (2000). Formation of highly porous biodegradable scaffolds for tissue engineering, *Electronic Journal of Biotechnology*, v.3, n.2, p.114-119.

NETO, B. B., SCARMINO, I. S. and BRUNS, R. E. (2007). Como fazer experimentos. 3th Edition, Campinas, SP: Editora UNICAMP, 480 p.

RODRIGUES, M. I. and Iemma, A. F. (2005). Planejamento de experimentos e otimização de processos. Campinas, SP: Editora casa do pão, 326 p.

SEAVEY, K. C. and LIU, Y. A. (2008). Step-Growth Polymerization Process Modeling and Product Design. New Jersey: John Wiley & Sons, Inc., 589 p. YOO, D. K. and KIM, D. (2006) Synthesis of Lactide from Oligomeric PLA: Effects of Temperature, Pressure, and Catalyst, *Macromolecular Research*, v. 14, n. 5, p. 510-516, 2006

7.3. Conclusões

O processo de síntese em batelada foi desenvolvido em três etapas: oligomerização, formação de lactídeo e polimerização. Na primeira etapa, foram achadas as variáveis que têm maior influência sobre o Fluxo Mássico de PLA (PMF) e o Número de Massa Molar (MWN) do oligômero. Para o PMF, no reator OLIG-R, Composição da Alimentação (FC) e Pressão (P) são as variáveis que mais afetam esta resposta. Por outro lado, os efeitos da variável Pressão (P) e da Temperatura (T) foram mais significativos sobre o MWN, que os das outras. Neste estágio do processo para a faixa estudada, os efeitos da Recuperação de Água na Coluna (WRC) não influenciam em nenhuma resposta. Os comportamentos das respostas foram avaliados, e foi achado um modelo quadrático estatístico para cada uma destas, os quais representam estes comportamentos e os predizem.

Para o segundo reator (LACTID-R), foram encontradas as variáveis que mais têm influência sobre a Pureza do Lactídeo (PL), o Fluxo Mássico do Lactídeo (LMF) e o Fluxo Mássico do Ácido Láctico (LAMF). Para o Fluxo Mássico Lactídeo, Temperatura (T) e Pressão (P) têm efeitos significativos sobre esta resposta. De outra forma, os efeitos da variável Pressão (P) não foram significativos sobre nenhuma resposta desta parte do processo. Os comportamentos das respostas foram avaliados e acharam-se modelos quadráticos estatísticos, os quais não representam, nem predizem bem o comportamento destas.

Para a polimerização (última etapa), foi encontrado que as variáveis que mais influenciam a Pureza do PLA (PP), o Fluxo Mássico de PLA (PMF) e Número de Massa Molar (MWN) do reator PLA-R foram: Recuperação de Água na Coluna (WRC), Temperatura (T) e Fluxo de Catalisador (C). As respostas PMF e PP são influenciadas em maior proporção pela Temperatura (T) e a Recuperação de Água na Coluna (WRC); a PP se viu também afetada pelo Fluxo de Catalisador (C). O MWN foi somente afetado pela Recuperação de Água da Coluna. Os efeitos da Pressão (P) não foram

** Guillermo Andrés Rueda Martínez **

significativos sobre nenhuma resposta em esta etapa. Os modelos quadráticos encontrados predizem e representam o comportamento das respostas.

Capítulo 8- Conclusões e Sugestões para Trabalhos Futuros

8.1 Conclusões

✓ A prototipagem rápida é uma técnica não convencional de biofabricação, a qual tem uma grande capacidade para produzir *scaffolds* de forma externa personalizada e morfologia interna pré-definidas. Este tipo de tecnologia permite utilizar matérias-primas diversas, em especial biomateriais, como polímeros, metais e cerâmicas. O PLA é um material polimérico usado em uma grande variedade de aplicações médicas tais como: engenharia tecidual (*scaffolds*), liberação controlada de medicamentos, dispositivos biomédicos, entre outras. Isto se deve à sua excelente biocompatibilidade (aceitação pelo corpo humano), alta degradabilidade em contato com fluidos corpóreos, capacidade de absorção no corpo humano e boas propriedades mecânicas.

✓ O ácido láctico é um produto de grande importância industrial para a produção de muitas substâncias químicas e, especialmente, serve como monômero na síntese do PLA. Este ácido pode ser produzido a partir da fermentação da sacarose contida no melão da cana-de-açúcar, o qual é um co-produto da indústria sucroalcooleira. Pode ser obtido também a partir da hidrólise do bagaço da cana-de-açúcar, que pode ser considerada uma biomassa disponível em abundância no Brasil.

✓ Para obter o PLA com elevada massa molar, foi necessário utilizar três reatores tanto no sistema contínuo como em batelada, obtendo-se dois subprodutos, um polímero de baixa massa molar, chamado oligômero e um dímero cíclico do ácido láctico, chamado lactídeo, produzidos no primeiro e segundo reator, respectivamente. O polímero final foi sintetizado por meio da abertura de anéis do lactídeo, no último reator do processo (PLA-R). Devido ao fato dos componentes do sistema possuir afinidades, a separação destes é difícil, mas muito importante neste processo de polimerização, visto que a concentração dos reagentes em cada um dos estágios afeta, fortemente, as

condições para atingir as melhores propriedades do PLA final, tais como o número de massa molar e grau de polimerização.

✓ Utilizando um processo de síntese de PLA em sistema contínuo no ASPEN PLUS®, foi possível sintetizar o PLA com massa molar (MWN) de 25183,60, adequado para o uso em biofabricação. Também foi demonstrado, por simulação no mesmo software, que é possível produzir um polímero de ácido láctico com elevada massa molar (MWN), utilizando reatores em batelada. O PLA obtido neste sistema apresentou massa molar de 42340,51, valor este que pode ser considerado alto e ótimo igual ao que foi achado no sistema contínuo, segundo Cheng *et al.* (2009), para o uso deste polímero em fabricação de *scaffolds* e dispositivos biomédicos.

✓ Os valores das variáveis, grau de polimerização e número de massa molar do polímero final (PLA) diminuíram quando a razão entre a quantidade de água e lactídeo alimentados no reator final (PLA-R), aumentou, também estas propriedades do polímero apresentam o mesmo comportamento quando a razão entre o ácido láctico e lactídeo aumenta. Portanto, para obter um polímero de elevada massa molar foi necessário separar a maior quantidade de água e ácido láctico possível, antes de iniciar a última reação.

✓ Na primeira etapa do processo de polimerização do PLA, foram achadas as variáveis que têm maior influência sobre o Fluxo Mássico de PLA (PMF) e o Número de Massa Molar (MWN). Para o PMF, no reator OLIG-R, Composição da Alimentação (FC) e Pressão (P) são as variáveis que mais afetam esta resposta. Por outro lado, os efeitos da variável Pressão (P) e da Temperatura (T) foram mais significativos sobre o MWN, que os das outras. Neste estágio do processo para a faixa estudada, os efeitos da Recuperação de Água na Coluna (WRC) não influenciam em nenhuma resposta.

✓ Para o segundo reator (LACTID-R), foram encontradas as variáveis que mais têm influência sobre a Pureza do Lactídeo (PL), o Fluxo Mássico do Lactídeo (LMF) e o Fluxo Mássico do Ácido Láctico (LAMF). Para o Fluxo Mássico Lactídeo, Temperatura

(T) e Pressão (P) têm efeitos significativos sobre esta resposta. De outra forma, os efeitos da variável Pressão (P) não foram significativos sobre nenhuma resposta desta parte do processo.

✓ Para a polimerização (última etapa), foi encontrado que as variáveis que mais influenciam a Pureza do PLA (PP), o Fluxo Mássico de PLA (PMF) e Número de Massa Molar (MWN) do reator PLA-R foram: Recuperação de Água na Coluna (WRC), Temperatura (T) e Fluxo de Catalisador (C). As respostas PMF e PP são influenciadas em maior proporção pela Temperatura (T) e a Recuperação de Água na Coluna (WRC); a PP se viu também afetada pelo Fluxo de Catalisador (C). O MWN foi somente afetado pela Recuperação de Água da Coluna. Os efeitos da Pressão (P) não foram significativos sobre nenhuma resposta nesta etapa.

8.2 Sugestões Para Trabalhos Futuros

✓ Obter, experimentalmente, os dados cinéticos do processo de síntese do poli (ácido láctico) para poder simular o processo através da planta virtual desenvolvida no Polymer Plus do ASPEN PLUS[®], comparando-se as simulações desenvolvidas, com as cinéticas propostas em outros trabalhos da literatura.

✓ Estudar o equilíbrio entre os componentes do sistema de síntese de PLA e simular as unidades de separação dos componentes (torres e evaporadores) com maior detalhamento.

✓ Estudar outras propriedades finais do material polimérico como a temperatura de transição vítrea (T_g), temperatura de fusão (T_m) e temperatura de cristalização (T_c), por meio da simulação.

• *Guillermo Andrés Rueda Martínez* •

Referências Bibliográficas

ACHMAD, F., YAMANE, K., QUAN, S. e KOKUGAN, T. Synthesis of polylactic acid by direct polycondensation under vacuum without catalysts, solvents and initiators, *Chemical Engineering Journal*, v.151, n.1-3, p.342-350, 2009

ADSUL, M. G., VARMA, A. J. e GOKHALE, V. Lactic acid production from waste sugarcane bagasse derived cellulose, *Green Chemistry*, v.9, n.1, p.58-62, 2007

ALEXIS, F. Factors affecting the degradation and drug-release mechanism of poly(lactic acid) and poly-[(lactic acid)-co-(glycolic acid)], *Polymer International*, v.54, n.1, p.36-46, 2005

AMASS, W., AMASS, A. e TIGHE, B. A review of biodegradable polymers: uses, current developments in the synthesis and characterization of biodegradable polyester, blends of biodegradable polymers and recent advances in biodegradation studies, *Polymer International*, v.47, n.2, p.89-144, 1999

ATALA, A. e LANZA, R. P. *Methods of tissue engineering*. San Diego: Elsevier, 2002

AURAS, R. A., HARTE, B. e SELKE, S. E. M. An overview of polylactides as packaging materials, *Macromolecular Bioscience*, v.4, n.9, p.835-864, 2004

AURAS, R. A., LIM, L. T., SELKE, S. E. M., e TSUJI, H. *Poly(Lactic Acid) : Synthesis, Structures, Properties, Processing, and Applications*. New Jersey: John Wiley & Sons, Inc., 2010

BACAKOVA, L., FILOVA, E., RYPACEK, F., SVORCIK, V. e Stary, V. Cell adhesion on artificial materials for tissue engineering, *Physiological Research*, v.53, p.35-45, 2004

BARAÚNA, GRAZIELLE DOS SANTOS. Obtenção e caracterização de membranas de PLDLA em aplicação como prótese para regeneração nervosa periférica. Campinas: Faculdade de Engenharia Química, Universidade Estadual de Campinas, 2007. Tese (Doutorado)

BÁRTOLO, P., MENDES, A. e JARDINI, A. L. *Bio-prototyping. Design & Nature II, 2004*. M. W. Collins & C. A. Brebbia (Editors), WIT Press, p.535-544.

BEHONICK, D. J., XING, Z., LIEU, S., BUCKLEY, J. M., LOTZ, J. C., MARCUCIO, R. S., WERB, Z., MICLAU, T. e COLNOT, C. Role of matrix metalloproteinase 13 in both endochondral and intramembranous ossification during skeletal regeneration, *PLoS ONE*, v.2, n.11, p.1-10, 2007

BLEACH, N. C., TANNER, K. E., KELLOMÄKI e TÖRMÄLÄ, P. Effect of filler type on the mechanical properties of self-reinforced polylactide-calcium phosphate composites, *Journal of Materials Science. Materials in Medicine*, v.12, n.10-12, p.911-915, 2001

BOUAPAO, L., TSUJI, H., TASHIRO, K., ZHANG, J. e HANESAKA, M. Crystallization, spherulite growth, and structure of blends of crystalline and amorphous poly(lactide), *Polymer*, v.50, n.16, p.4007-4017, 2009

BROZ, M. E., VAN DER HART, D. L. e WASHBURN, N. R. Structure and mechanical properties of poly(D, L -lactic acid)/poly(α -caprolactone) blends, *Biomaterials*, v.24, n.23, p.4181-4190, 2003

BURKERSRODA, F. V., SCHEDL, L. e GOPFERICH, A. Why degradable polymers undergo surface erosion or bulk erosion, *Biomaterials*, v.23, n.21, p.4221-4231, 2002

CANCEDDA, R., GIANNONI, P. e MASTROGIACOMO, M. A tissue engineering approach to bone repair in large animal models and in clinical practice, *Biomaterials*, v.28, n.29, p.4240-4250, 2007

CAPLAN, A. I. New era of cell-based orthopedic therapies, *Tissue Engineering Part B: Review*, v.15, n.2, p.195-200, 2009

CHA, Y. e PITT, C. G. The biodegradability of polyester blends. *Biomaterials*, v.11, p.108-112, 1990

CHEAH, C. M., CHUA, C. K., LEONG, K. F. e CHUA, S. W. Development of a tissue engineering scaffold structure library for rapid prototyping. Part 1: investigation and classification, *The International Journal of Advanced Manufacturing Technology*, v.21, n.4, p.291-301, 2003

CHEN, G., USHIDA, T. e TATEISHI, T. Scaffold design for tissue engineering, *Macromolecular Bioscience*, v.2, p.67-77, 2002

CHEN, G., ZHOU, P., MEI, N., CHEN, X., SHAO, Z., PAN, L. e WU, C. Silk fibroin modified porous poly(ϵ -caprolactone) scaffold for human fibroblast culture in vitro, *Journal of Materials Science: Materials in Medicine*, v.15, n.6, p.671-677, 2004

CHEN, Y., MAK, A. F. T., WANG, M., LI, J. e WONG, M. S. PLLA scaffolds with biomimetic apatite coating and biomimetic apatite/collagen composite coating to enhance osteoblast-like cells attachment and activity, *Surface and Coatings Technology*, v.201, p.575-580, 2006

CHENG, Y., DENG, S., CHEN, P. e RUAN, R. Polylactic acid (PLA) synthesis and modifications: a review, *Frontiers of Chemistry in China*, v.4, n.3, p.259-264, 2009

CHANFREAU, S., MENA, M., PORRAS-DOMINGUEZ, J. R., RAMIREZ-GILLY, M., GIMENO, M., ROQUERO, P., TECANTE, A. e BARZANA, E. Enzymatic synthesis of poly-L-lactide and poly-L-lactide-co-glycolide in an ionic liquid, *Bioprocess and Biosystems Engineering*, v.33, p.629-638, 2010

CIMA, L. G., VACANTI, J. P., VACANTI, C., INGBER, D., MOONEY, D. e LANGER, R. Tissue engineering by cell transplantation using degradable polymer substrates, *Journal of Biomechanical Engineering*, v.113, n.2, p.143-151, 1991

COUTU, D. L., YOUSEFI, A. M. e GALIPEAU, J. Three-dimensional porous scaffolds at the crossroads of tissue engineering and cell-based gene therapy, *Journal of Cellular Biochemistry*, v.108, n.3, p.537-546, 2009

DAI, W., KAWAZOE, N., LIN, X., DONG, J. e CHEN, G. The influence of structural design of PLGA/collagen hybrid scaffolds in cartilage tissue engineering polymers, *Biomaterials*, v.31, n.8, p.2141-2152, 2010

DEARNALEY, G., ASHER, J., PEACOCK, A. T., ALLEN, S. J. e WATKINS, R. E. J. The use of thin layer activation to evaluate ion beam surface treatments of orthopaedic implant materials, *Surface and Coatings Technology*, v.201, n.19-20, p.8070-8075, 2007

DRUMRIGHT, R. E., GRUBER, P. R. e HENTON, D. E. Polylactic acid technology, *Advances Materials*, v.12, n.23, p.1841-1846, 2000

DUEK, E. A. R., ZAVAGLIA, C. A. C. e BELANGERO, W. D. In vitro study of poly(lactic acid) pin degradation, *Polymer*, v.40, n.23, p.6465-6473, 1999

DURSELEN, L., DAUNER, M., HIERLEMANN, H., PLANCK, H., CLAES, L. E., e IGNATIUS, A. Resorbable polymer fibers for ligament augmentation, *Journal of Biomedical Materials Research*, v.58, n.6, p.666–672, 2001

DUTKIEWICZ, S., GROCHOWSKA-LAPIENIS, D. e TOMASZEWS, W. Synthesis of Poly(L+) Lactic Acid) by Polycondensation Method in Solution, *FIBRES & TEXTILES in Eastern Europe*, v.11, n.4, p.66-70, 2003

ENVISION TEC, Disponível em: <http://www.envisiontec.de>. Acessada: Abril de 2010.

EPPLEY, B. L., MORALES, L., WOOD, R., PENSLER, J., GOLDSYEIN, J., HAVLIK, R. J., HABAL, M., LOSKEN, A., WILLIAMS, J. K., BURSTEIN, F., ROZZELLE, A. A. e SADOVE, A. Resorbable PLLA-PGA plate and Screw Fixation in pediatric Craniofacial surgery: Clinical Experience in 1883 patients, *Plastic & Reconstructive Surgery*, v.114, n.4, p.850-856, 2004

FANG, Z., STARLY, B. e SUN, W. Computer-aided characterization for effective mechanical properties of porous tissue scaffolds, *Computer-Aided Design*, v.37, n.1, p.65-72, 2005

FAO Statistics Division, Disponível em: <http://www.faostat.fao.org>. Acessada: Abril de 2010.

FREED, L. E., MARQUIS, J. C., LANGER, R., VUNJAK-NOVAKOVIC, G. e EMMANUAL, J. Composition of cell-polymer cartilage implants, *Biotechnology and Bioengineering*, v.43, n.7, p.605-614, 1994

FREED, L. E., MARQUIS, J. C., NOHRIA, A., EMMANUAL, J., MIKOS, A. G. e LANGER, R. Neocartilage formation in vitro and in vivo using cells cultured on synthetic biodegradable polymers, *Journal of Biomedical Materials Research*, v.27, n.1, p.11-23, 1993

FREED, L. E. e VUNJAK-NOVAKOVIC, G. Culture of organized cell communities, *Advanced Drug Delivery Reviews*, v.33, p.15-30, 1998

FREED, L. E., VUNJAK-NOVAKOVIC, G., BIRON, R. J., EAGLES, D. B., LESNOY, D. C., BARLOW, S. K. e LANGER, R. Biodegradable polymer scaffolds for tissue engineering, *Nature Biotechnology*, v.12, p.689-693, 1994

FUKUSHIMA, K. e KIMURA, Y. An Efficient Solid-State Polycondensation Method for Synthesizing Stereocomplexed Poly(Lactic Acid)s with High Molecular Weight. *Journal of Polymer Science Part A: Polymer Chemistry*, v.46, p.3314-3322, 2008

GARLOTTA, D. A literature review of poly(lactic acid), *Journal of Polymers and the Environment*, v.9, n.2, p.63-84, 2001

GARVIE, E. L. Bacterial lactate dehydrogenases, *Microbiology Reviews*, v.44, p.106-139, 1980

GOLDEN, M. A., HANSON, S. R., KIRKMAN, T. R., SCHNEIDER, P. A. e CLOWES, A. W. Healing of polytetrafluoroethylene arterial grafts is influenced by graft porosity, *Journal of Vascular Surgery*, v.11, n.6, p.838-844, 1990

GRIFFITH, L. G. Polymeric biomaterials, *Acta Materials*, v.48, p.263-277, 2000

GU, S., Y., YANG, M., YU, T., REN, T. B. e REN, J. Synthesis and characterization of biodegradable lactic acid-based polymers by chain extension, *Polymer International*, v.57, n.8, p.982-986, 2008

GUPTA, B., REVAGADE, N. e HILBORN, J. Poly(lactic acid) fiber: An overview, *Progress in Polymer Science*, v.34, n.4, p.455-482, 2007

HEDBERG, E. L., KROESE-DEUTMAN, H. C., SHIH, C. K., CROWTHER, R. S., CARNEY, D. H., MIKOS, A. G. e JANSEN, J. A. In vivo degradation of porous poly(propylene fumarate)/poly(DL-lactic-co-glycolic acid) composite scaffolds, *Biomaterials*, v.26, n.22, p.4616-4623, 2005

HENTON, D. E. GRUBER, P., LUNT, J. e RANDALL, J. *Poly(lactic Acid) Technology. Natural Fibers, Biopolymers and Biocomposites*, A. K. Mohanty (Editors), CRC Press, p.528-569, 2005

HOFVENDAHL, K. e HAHN-HÄGERDAL, B. Factors affecting the fermentative lactic acid production from renewable resources, *Enzyme and Microbial Technology*, v.26, n.2-4, p.87-107, 2000

HOLLISTER, S. J. Porous scaffold design for tissue engineering, *Nature Materials*, v.4, p.518-524, 2005

HSU, Y. Y., GRESSER, J. D., TRANTOLO, D. J., LYONS, C. M., GANGADHARAM, P. R. e WISE, D. L. Effect of polymer foam morphology and density on kinetics of in vitro controlled releases of isoaniazid from compressed foam matrices, *Journal of Biomedical Materials Research*, v.35, n.1, p.107-116, 1997

HUGHES, T. B. Bioabsorbable implants in the treatment of hand fractures: an update, *Clinical Orthopaedics and Related Research*, v.445, p.169-174, 2006

IGNJATOVIC, N e USKOKOVIC, D. Synthesis and application of hydroxyapatite/polylactide composite biomaterial, *Applied Surface Science*, v.238, n.1-4, p.314-319, 2004

IMOLA, M. J. e SCHRAMM V. L. Resorbable Internal Fixation in Pediatric Cranial Base Surger, *The Laryngoscope*, v.112, n. 10, p.1897-1901, 2009

JARDINI, A. L., LUNELLI, B. H., MARTINEZ, G. A. R., LASPRILLA, A. J. R., DA SILVA, J. V. L., MACIEL FILHO, R. Computer-Aided Tools for Modeling and Simulation in the Biomaterials Production. In: Latin American Congress of Artificial Organs and Biomaterials (COLAOB). Gramado, Brasil, 2010

JHON, R. P., ANISHA, G. S., NAMPOOTHIRI, K. M. e PANDEY, A. Direct lactic acid fermentation: Focus on simultaneous saccharification and lactic acid production, *Biotechnology Advances*, v.27, n.2, p.145-152, 2009

JOHN, R. P., NAMPOOTHIRI, K. M., NAIR, A. S. e PANDEY, A. L-Lactic acid production using *Lactobacillus casei* in solid-state fermentation, *Biotechnology Letters*, v.27, n.21, p.1685–1688, 2005

JHON, R. P., NAMPOOTHIRI, K. M. e PANDEY, A. Fermentative production of lactic acid from biomass: an overview on process developments and future perspectives, *Applied Microbiology and Biotechnology*, v.74, n.3, p.524-534, 2007

KELLOMÄKI, M., NIIRANEN, H., PUUMANEN, K., ASHAMMAKHI, N., WARIS, T. e TÖRMÄLÄ, P. Bioabsorbable scaffolds for guided bone regeneration and generation, *Biomaterials*, v.21, n.24, p.2495–2505, 2000

KIM, B. S. e MOONEY, D. J. Development of biocompatible synthetic extracellular matrices for tissue engineering, *Trends in Biotechnology*, v.16, n.5, p.224-230, 1998

KIM, E., SHIN, E. W., YOO, I. K. e CHUNG, J. S. Characteristics of heterogeneous titanium alkoxide catalysts for ring-opening polymerization of lactide to produce polylactide, *Journal of Molecular Catalysis A: Chemical*, v.298, n.1-2, p.36-39, 2009

KIM, K. W. e WOO, S. I. Synthesis of High-Molecular-Weight Poly(L-lactic acid) by Direct Polycondensation. *Macromolecular Chemistry & Physics*, v.203, n.15, p.2245–2250, 2002

KINOSHITA, Y., KOBAYASHI, M., FUKUOKA, S., YOKOYA, S., e IKADA, Y. Reconstruction of jawbones using poly(L- lactic acid) mesh and transplantation of particulate cancellous bone and marrow, *Tissue Engineering*, v.2, n.4, p.117, 2003

KRICHELDORF, H. R. e LEE, S. R. (1995). Polylactones: 32. High-molecular-weight polylactides by ring-opening polymerization with dibutylmagnesium or butylmagnesium chloride, *Polymer*, v. 36, n. 15, p. 2995-3003.

KULKARNI, M., GREISER, U., O'BRIEN, T. e PANDIT, A. Liposomal gene delivery mediated by tissue-engineered scaffolds, *Trends in Biotechnology*, v.28, n.1, p.28-36, 2010

LALAN, S., POMERANTSEVA, I. e VACANTI, J. P. Tissue engineering and its potential impact on surgery, *World Journal of Surgery*, v.25, n.11, p.1458-1466, 2001

LAM, C. X. F., MO, X. M., TEOH, S. H. e HUTMACHER, D. W. Scaffold development using 3D printing with a starch-based polymer, *Materials Science and Engineering*, v.20, p.49-56, 2002

LAMPE, K. J., NAMBA, R. M., SILVERMAN, T. R., BJUGSTAD, K. B. e MAHONEY, M. J. Impact of lactic acid on cell proliferation and free radical induced cell death in monolayer cultures of neural precursor cells, *Biotechnology and Bioengineering*, v.103, n.6, p.1214-1223, 2009

LANDERS, R., PFISTER, A., HÜBNER, U., JOHN, H., SCHMELZEISEN, R. e MÜLHAUPT, R. Fabrication of soft tissue engineering scaffolds by means of rapid prototyping techniques, *Journal of Materials Science*, v.37, n.15, p.3107-3116, 2002

LANGER, R. Selected advances in drug delivery and tissue engineering, *Journal Controlled Release*, v.62, p.7-11, 1999

LANGER, R. e VACANTI, J. P. *Tissue engineering, Science*, v.260. n.5110, p.920-926, 1993

LANZETTA, M. e OWEN, E. Achieving better patency rates and neoendothelialization in 1-milimeter polytetrafluoroethylene grafts by varying fibril length and wall thickness, *Microsurgery*, v.13, n.2, p.76-83, 2005

LASPRILLA, A. J. R., MARTINEZ, G. A. R., LUNELLI, B. H., JARDINI, A. L. e MACIEL FILHO, R. Poly-lactic acid synthesis for application in biomedical devices — A review, *Biotechnology Advances, Article in Press, Corrected Proof.*, 2011

LEE, S. H. e SHIN, H. Matrices and scaffolds for delivery of bioactive molecules in bone and cartilage tissue engineering, *Advanced Drug Delivery Reviews*, v.59, p.339–359, 2007

LEONG, K. F., CHEAH, C. M. e CHUA, C. K. Solid freeform fabrication of three-dimensional scaffolds for engineering replacement tissue and organs, *Biomaterials*, v.24, n.13, p.2363-2378, 2003

LIM, L. T., AURAS, R. e RUBINO, M. Processing technologies for poly(lactic acid), *Progress in Polymer Science*, v.33, p.820-852, 2008

LINDQVIST, C., SÖDERHOLM, A. L., HALLIKAINEN, D. e SJÖVALL, L. Erosion and heterotopic bone formation after alloplastic temporomandibular joint reconstruction, *Journal of Oral and Maxillofacial Surgery*, v.50, n.9, p.942-949, 1992

LIU, C. Z. e CZERNUSZKA, J. T. Development of biodegradable scaffolds for tissue engineering: a perspective on emerging technology, *Materials Science and Technology*, v.23, n.4, p.379-391, 2007

LO, H., PONTICIELLO, M. S. e LEONG, K. W. Fabrication of controlled release biodegradable foams by phase separation, *Tissue Engineering*, v.1, n.1, p.15-28, 1995

LOVALD, S. T., KHRAISHI, T., WAGNER, J. e BAACK, B. Mechanical Design Optimization of Bioabsorbable Fixation Devices for Bone Fractures. *The Journal of Craniofacial Surgery*, v.20, n.2, p.389-398, 2009

LUNELLI, B. H. *Produção e Controle da Síntese do Éster de Ácido Acrílico Através da Fermentação do Ácido Láctico*. Campinas, SP: Faculdade de Engenharia Química, Universidade Estadual de Campinas, 2010. Tese (Doutorado)

LUNELLI, B. H., ANDRADE, R. R., ATALA, D. I. P., MACIEL, M. R. W., MAUGERI FILHO, F. e MACIEL FILHO, R. Production of lactic acid from sucrose: strain selection, fermentation, and kinetic modeling, *Applied Biochemistry and Biotechnology*, v.161, n. 1-8, p.227-237, 2010

LUNELLI, B. H., LASPRILLA, A. J. R., MARTINEZ, G. A. R., JARDINI, A. L. e MACIEL FILHO, R. Poly-lactic acid production from brazilian renewable feedstock for application in biomedical devices. In LATIN AMERICAN CONGRESS OF ARTIFICIAL ORGANS AND BIOMATERIALS, VI, 2010. 216-2.

MACIEL FILHO, R., BINELI, A. R. R. e JARDINI, A. L. Bio-fabrication integrated computational tools. In International Symposium on Process Systems Engineering, X, 2009

MAINIL-VARLET, P., CURTIS, R. e GOGOLEWSKI, S. Effect of in vivo and in vitro degradation on molecular and mechanical properties of various low-molecular-weight polylactides, *Journal of Biomedical Materials Research*, v.36, n.3, p.360-380, 1997

MALMGREN, I., MAYS, J. e PYDA, M. Characterization of poly(lactic acid) by size exclusion chromatography, differential refractometry, light scattering and thermal analysis, *Journal of Thermal Analysis and Calorimetry*, v.83, n.1, p.35-40, 2006

MARTINEZ, G. A. R., LASPRILLA, A. J. R., LUNELLI, B. H., JARDINI, A. L., MACIEL FILHO, R. (2011). Modeling and Simulation of Poly (Lactic Acid) Synthesis from Renewable Feedstock for Application in Biomedical Devices, *Computer Aided Chemical Engineering*, v. 29, p. 346-350, 2011

MEHTA, R. *Modeling and Simulation of Poly(Lactic Acid) Polymerization*. Patiala: Thapar Institute of Engineering and Technology, Deemed University, 2007. Tese (Doutorado)

MEHTA, R., KUMAR, V., BHUNIA, H. e UPADHYAY, S. N. Synthesis of Poly(Lactic Acid): A Review, *Journal of Macromolecular Science, Part C: Polymer Reviews*, v.45, n.4, p.325-349, 2005

MIDDLETON, J. C. e TIPTON, A. J. Synthetic biodegradable polymers as orthopedic devices, *Biomaterials*, v.21, n.23, p.2335-2346, 2000

MIKOS, A. G. e TEMENOFF, J. S. Formation of highly porous biodegradable scaffolds for tissue engineering, *Electronic Journal of Biotechnology*, v.3, n.2, p.114-119, 2000

MIKOS, A. G., THORSEN, A. J., CZERWONKA, L. A., BAO, Y., LANGER, R., WINSLOW, D. N. e VACANTI, J. P. Preparation and characterization of poly(L-lactic acid) foams, *Polymer*, v.35, n.5, p.1068-1077, 1994

MILOVANOVIĆ, J. e TRAJANOVIĆ, M. Medical applications of rapid prototyping, *Mechanical Engineering*, v.5, n.1, p.79-85, 2007

MOONEY, D. J., BALDWIN, D. F., SUH, N. P., VACANTI, J. P. e LANGER, R. Novel approach to fabricate porous sponges of poly (D, L – lactic-co-glycolic acid) without the use of organic solvents, *Biomaterials*, v.17, n.14, p.1417-1422, 1996

MOONEY, D. J., ORGAN, G., VACANTI, J. P. e LANGER, R. Design and fabrication of biodegradable polymer devices to engineer tubular tissues, *Cell Transplantation*, v.3, n.2, p.203-210, 1994

MUGGLI, D. S., BURKOTH, A. K. e ANSETH, K. S. Crosslinked polyanhydrides for use in orthopedic applications: degradation behavior and mechanics, *Journal of Biomedical Materials Research*, v.46, n.2, p.271-278, 1999

NAIR, L. S. e LAURENCIN, C. T. Biodegradable Polymers as Biomaterials, *Progress in Polymer Science*, v.32, n.8-9 p.762-798, 2007

NAMPOOTHIRI, K. M., NAIR, N. R. e JOHN, R. P. An overview of the recent developments in polylactide (PLA) research, *Bioresource Technology*, v.101, n.22, p.8493-8501, 2010

NEJATI, E., FIROUZDOR, V., ESLAMINEJAD, M. B. e BAGHERI, F. Needle-like nano hydroxyapatite/poly(L-lactide acid) composite scaffold for bone tissue engineering application, *Materials Science and Engineering:C*, v.29, n.3, p.942-949, 2009

NETO, B. B., SCARMINIO, I. S. e BRUNS, R. E. *Como fazer Experimentos. Campinas, SP: Editora Unicamp, 2007*

OYAMA, H. T., TANAKA, Y. e KADOSAKA, A. Rapid controlled hydrolytic degradation of poly(l-lactic acid) by blending with poly(aspartic acid-co-l-lactide), *Polymer Degradation and Stability*, v.94, n.9, p.1419-1426, 2009

PAPENBURG, B. J., LIU, J., HIGUERA, G. A., BARRADAS, A. M. C., BÔER, J., VAN BLITTERSWIJK, C. A., WESSLING, M. e STAMATIALIS, D. Development and analysis of multi-layer scaffolds for tissue engineering, *Biomaterials*, v.30, n.31, p.6228-6239, 2009

PARK, K. E., KANG, H. K., LEE, S. J., MIN, B. M. e PARK, W. H. Biomimetic nanofibrous scaffolds: preparation and characterization of PGA/Chitin Blend Nanofibers, *Biomacromolecules*, v.7, n.2, p. 635-643, 2006

PETER, S. J., LU, L., KIM, D. J. e MIKOS, A.G. Marrow stromal osteoblast function on a poly(propylene fumarate)/b-tricalcium phosphate biodegradable orthopaedic composite, *Biomaterials*,v.21, p.1207–1213, 2000

PETER, S. J., MILLER, M. J., YASKO, A. W., YASZEMSKI, M. J. e MIKOS, A. G. Polymers concepts in tissue engineering, *Journal of Biomedical Materials Research*, v.43, n.4, p.422-427, 1998

PHILP, A., McDONALD, A. L. and WATT, P. W. Lactate – a signal coordinating cell and systemic function, *Journal of Experimental Biology*, v.208, n.24, p.4561-4575, 2005

PROCESS SIMULATION WITH POLYMER PLUS®. Course Number ES280.121.03. ASPEN TECHNOLOGY, Inc., 2004

PUAUX, J. P., BANU, I., NAGY, I e BOZGA, G. A Study of L-Lactide Ring-Opening Polymerization Kinetics, *Macromolecular Symposia*, v.259, n.1, p.318–326, 2007

QUYNH, T. M., MITOMO, H., ZHAO, L. e ASAI, S. The radiation crosslinked films based on PLLA/PDLA stereocomplex after TAIC absorption in supercritical carbon dioxide, *Carbohydrate Polymer*, v.72, n.4, p.673-681, 2008

RAHAMAN, M. N. e MAO, J. J. Stem cell-based composite tissue constructs for regenerative medicine, *Biotechnology and Bioengineering*, v.91, n.3, p.261-284, 2005

RODRIGUES, M. I. e IEMMA, A. F. Planejamento de experimentos e otimização de processos. Campinas, SP: Editora casa do pão, 2005

SACHLOS, E. e CZERNUSZKA, J. T. Making tissue engineering scaffolds work. Review: the application of solid freeform fabrication technology to the production of tissue engineering scaffolds, *European Cells & Materials*, v.5, p.29-39, 2003

SEAVEY, K. C. e LIU, Y. A. *Step-Growth Polymerization Process Modeling and Product Design*. New Jersey: John Wiley & Sons, Inc., 2008, 589 p.

SCIME, A., CARON, A. Z. e GRENIER, G. Advances in myogenic cell transplantation and skeletal muscle tissue engineering, *Frontiers in Bioscience*, v.14, n. 1, p.3012–3023, 2009

SÖDERGARD, A. e STOLT, M. Properties of lactic acid based polymers and their correlation with composition, *Progress in Polymer Science*, v.27, n.6 p.1123-1163, 2002

TAN, M. L., CHOONG, P. F. M., e DASS, C. R. Recent developments in liposomes, microparticles and nanoparticles for protein and peptide drug delivery, *Peptides*, v.31, n.1, p.184-193, 2010

TEMENOFF, J. S. e MIKOS, A. G. Review: tissue engineering for regeneration of articular cartilage, *Biomaterials*, v.21, n.5, p.431-440, 2000

THOMAS, T. D., ELLWOOD, D. C. e LONGYEAR, V. M. C. Change from homo-to-heterolactic fermentation by *Streptococcus lactis* resulting from glucose limitation in anaerobic chemostat cultures, *Journal of Bacteriology*, v.138, n.1, p.109-117, 1979

THOMSON, R. C., WAKE, M. C., YASZEMSKI, M. J. e MIKOS, A. G. Biodegradable polymer scaffolds to regenerate organs, *Advances in Polymer Science*, v.122, n.1, p.247-274, 1995a

THOMSON, R., YASZEMSKI, M. e MIKOS, A. *Polymer scaffold processing. Principles of tissue engineering*, R. Lanza, R. Langer, W. Chick (Editors), Academic Press, p.263-272, 1997

THOMSON, R. C., YASZEMSKI, M. J., POWERS, J. M. e MIKOS, A. G. Fabrication of biodegradable polymer scaffold to engineer trabecular bone, *Journal of Biomaterials Science*, v.7, n.1, p.23-38, 1995b

TSUJI, H. e ISHIDA, T. Poly(L-lactide).X. Enhanced surface hydrophilicity and chain scission mechanisms of poly(L-lactide) film in enzymatic, alkaline, and phosphate-buffered solutions, *Journal of Applied Polymer Science*, v.87, p.1628-1633, 2003

VALANTIN, M. A., AUBRON-OLIVIER, C., GHOSN, J., LAGLENNE, E., PAUCHARD, M., SCHOEN, H., BOUSQUET, R., KATZ, P., COSTAGLIOLA, D. e KATLAMA, C. Polylactic acid implants (New-Fill) to correct facial lipoatrophy in HIV-infected patients: results of the open-label study, *AIDS*, v.17, n.17, p.2471-2477, 2003

VARADARAJAN, S. e MILLER, D. J. Catalytic upgrading of fermentation-derived organic acids, *Biotechnology Progress*, v.15, n.15, p.845-854, 1999

WALTER LORENZ SURGICAL Inc., Disponível em: <http://www.lorenzsurgical.com>. Acessada: Abril de 2010.

WANG, S., NISHIDE, H. e TSUCHIDA, E. Oxygen permeability of biodegradable copolycaprolactones, *Polymer for Advances Technologies*, v.10, n.5, p.282-286, 1999

WARIS, E. KONTTINEN, Y. T., ASAMMAKHI, N., SUURONEN, R. e SANTAVIRTA, S. Bioabsorbable fixation devices in trauma and bone surgery: current clinical standing, *Expert Review of Medical Devices*, v.1, n.2, p.229-240, 2004

WHANG, K., THOMAS, C. H., HEALVY, K. E. e NUBER, G. A novel method to fabricate bioabsorbable scaffolds, *Polymer*, v.36, n.4, p.837-842, 1995

WEN, C. E., YAMADA, Y., SHIMOJIMA, K., CHINO, Y., ASAHINA, T. e MABUCHI, M. Processing e mechanical properties of autogenous titanium implant materials, *Materials in Medicine*, v.13, n.4, p.397-401, 2002

WITZKE, D. R. e NARAYAN, R. Reversible Kinetics and Thermodynamics of the Homopolymerization of L-Lactide with 2-Ethylhexanoic Acid Tin(II) Salt, *Macromolecules*, v.30, n.23, p.7075-7085, 1997

YAMANE, H. e SASAI, K. Effect of the addition of poly(D-lactic acid) on the thermal property of poly(L-lactic acid), *Polymer*, v.44, n.8, p.2569-2575, 2003

YANG, S., LEONG, K. F., DU, Z. e CHUA, C. K. The design of scaffolds for use in tissue engineering: Part I. Traditional factors, *Tissue Engineering*, v.7, n.6, p.679-689, 2001

YANG, S., LEONG, K. F., DU, Z. e CHUA, C. K The design of scaffolds for use in tissue engineering. Part II. Rapid prototyping techniques, *Tissue Engineering*, v.8, n.1, p.1–11, 2002

YANG, F., MURUGAN, R., RAMAKRISHNA, S., WANG, X., MA, X. e WANG, S. Fabrication of nano-structured porous PLLA scaffold intended for nerve tissue engineering, *Biomaterials*, v.25, n.10, p.1891-1900, 2004

YEONG, W. Y., CHUA, C. K., LEONG, K. F. e CHANDRASEKARAN, M. Rapid prototyping in tissue engineering: challenges and potential, *Trends in Biotechnology*, v.22, n.12, p.643-652, 2004

YOO, D. K. e KIM, D. (2006) Synthesis of Lactide from Oligomeric PLA: Effects of Temperature, Pressure, and Catalyst, *Macromolecular Research*, v. 14, n. 5, p. 510-516.

YU, Y., STORTI, G. e MORBIDELLI, M. Ring-Opening Polymerization of L,L-Lactide: Kinetic and Modeling Study, *Macromolecules*, v.42, p.8187–819, 2009

ZHANG, X., McDONALD, D. A., GOOSEN, M. F. A., e McAULEY, K. B. Mechanism of lactide polymerization in the presence of stannous octoate: The effect of hydroxy and carboxylic acid substances, *Journal Polymer Science. Part A: Polymer Chemistry*, v.32, n.15, p.2965–2970, 1994

ANEXO A. Perfis de Reatores CSTR

A Tabela A.1 apresenta as condições de operação do reator CSTR de oligomerização do capítulo 5 (OLIG-R).

Tabela A. 1. Condições de operação OLIG-R.

VARIÁVEIS OPERACIONAIS	OLIG-R
Temperatura [K]	483,15
Pressão [atm]	2
Fases	Líquida/Vapor
Volume [L]	30000

As Figuras A.1, A.2 e A.3 apresentam os perfis de fluxo mássico dos componentes no reator CSTR de oligomerização do capítulo 5 (OLIG-R).



Figura A. 1. Fluxos mássicos variando a temperatura do OLIG-R.



Figura A. 2. Fluxos mássicos variando a pressão do OLIG-R.

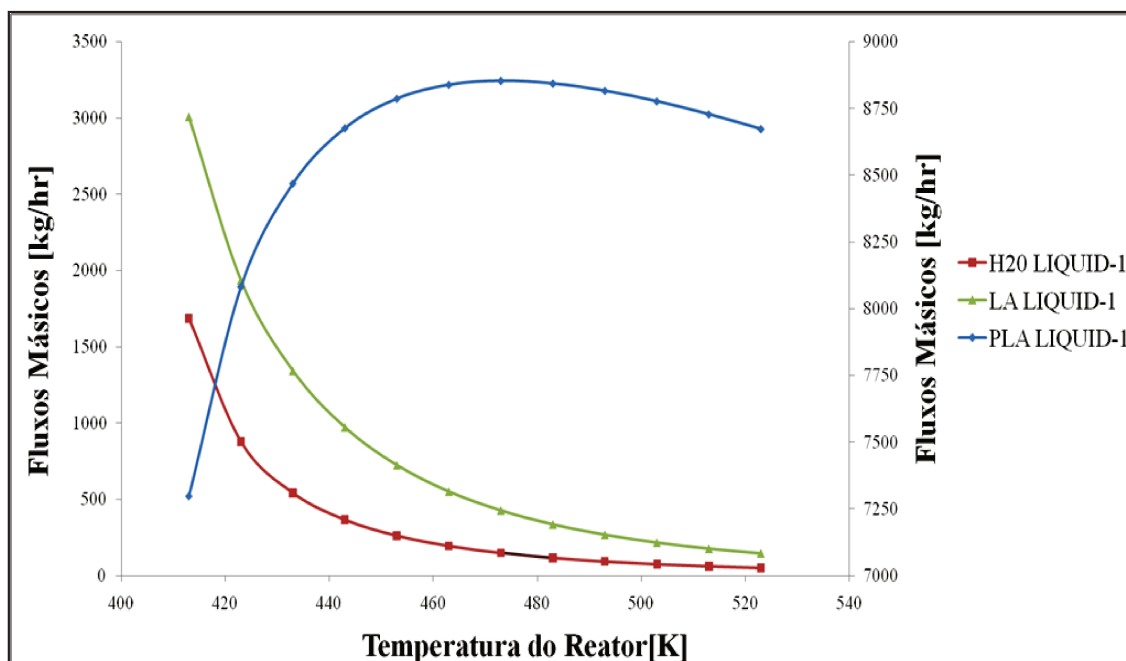

Figura A. 3. Fluxos mássicos variando o volume do OLIG-R

A Tabela A.2 apresenta as condições de operação do reator CSTR de formação de lactídeo do capítulo 5 (LACTID-R).

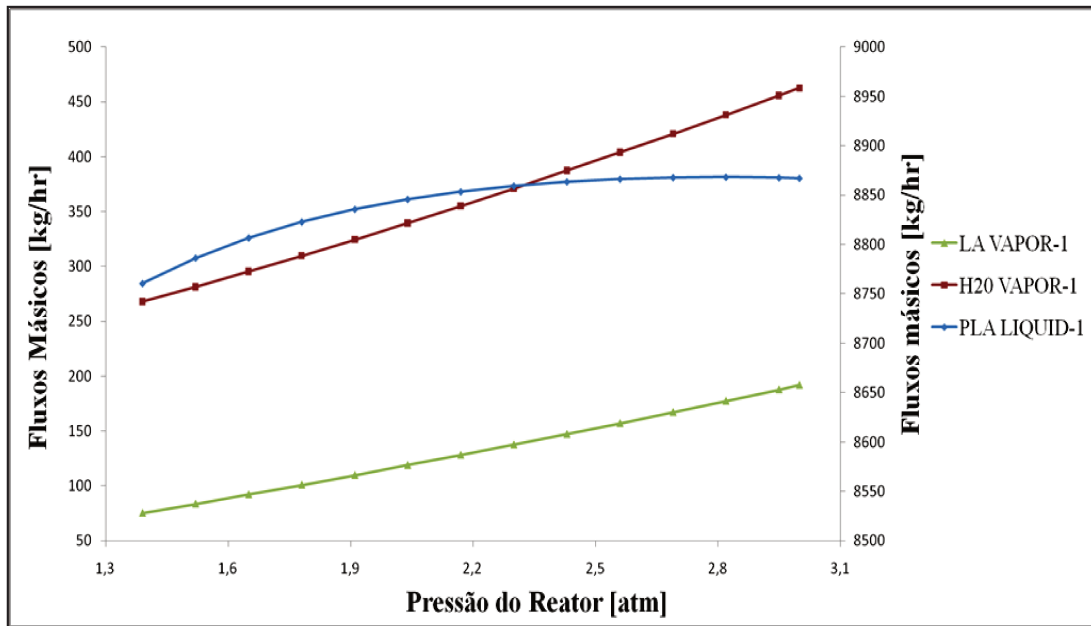
* Modelagem e simulação do processo de produção de PLA (poli-ácido láctico) obtido a partir de fontes renováveis para uso biomédico *

Tabela A. 2. Condições de operação LACTID-R.

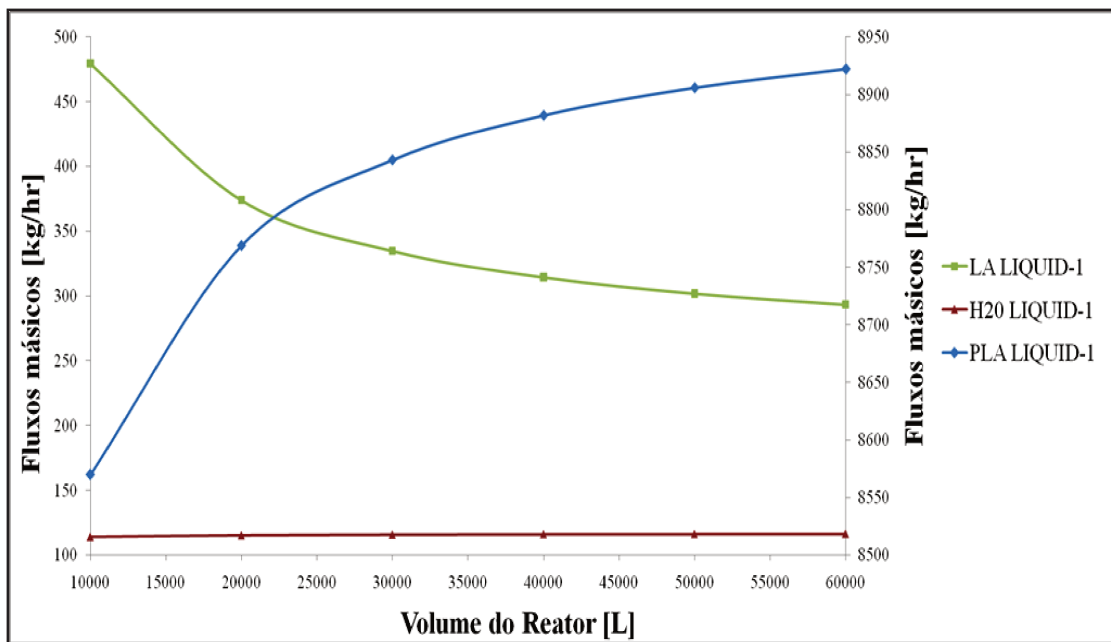
VARIÁVEIS OPERACIONAIS	LACTID-R
Temperatura [K]	493,15
Pressão [atm]	0,5
Volume [L]	30000
Fases	Líquida
CAT-1 [kg/hr]	1

As Figuras A.4, A.5, A.6 e A.7 apresentam os perfis de fluxo mássico dos componentes no reator CSTR de formação de lactídeo do capítulo 5 (LACTID-R).



Figura A. 4. Fluxos mássicos variando a temperatura do LACTID-R.



Figura A. 5. Fluxos mássicos variando a pressão do LACTID-R.

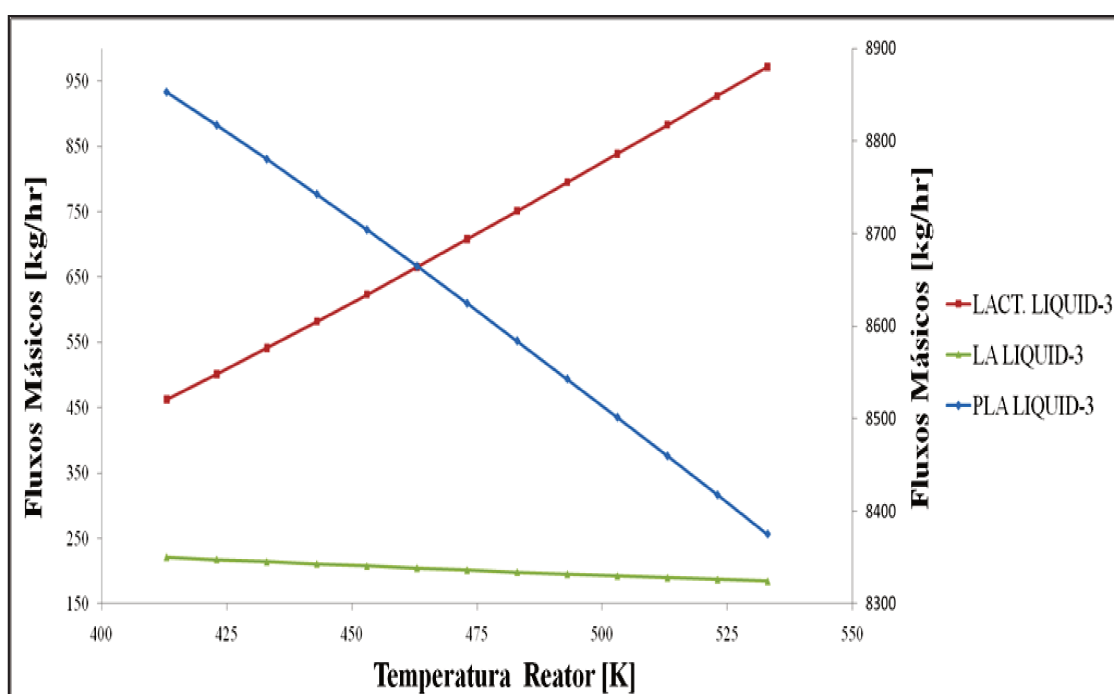

Figura A. 6. Fluxos mássicos variando o volume do LACTID-R.

• Modelagem e simulação do processo de produção de PLA (poli-ácido láctico) obtido a partir de fontes renováveis para uso biomédico •

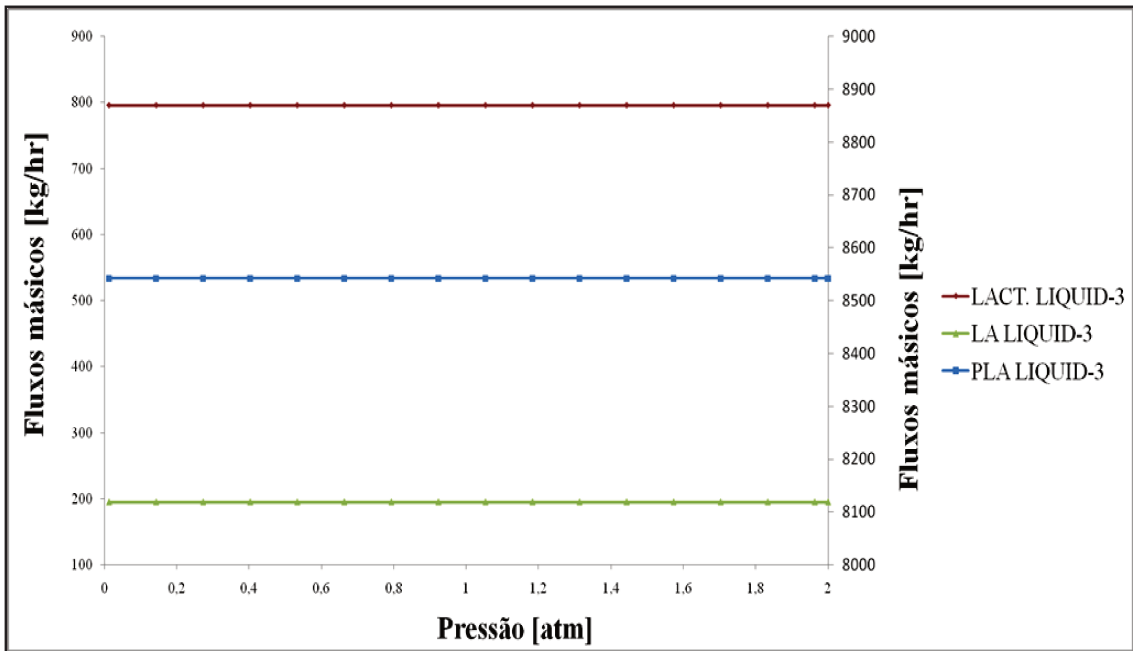

Figura A. 7. Fluxos mássicos variando o fluxo de catalisador do LACTID-R.

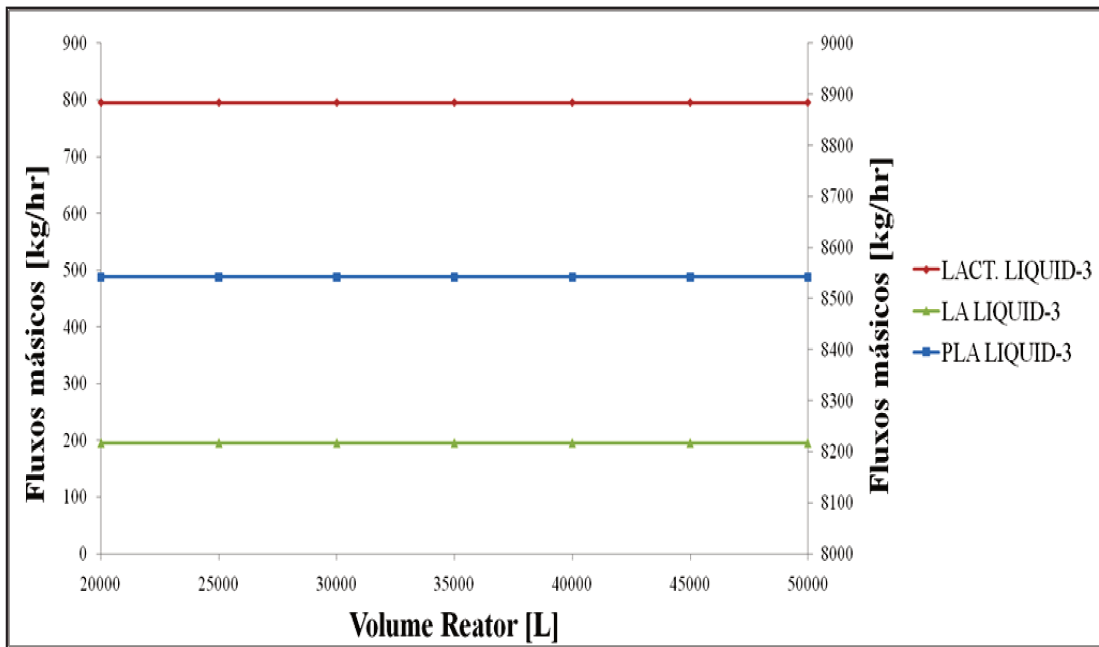
A Tabela A.3 apresenta as condições de operação do reator CSTR de polimerização do capítulo 5 (LACTID-R).

Tabela A. 3. Condições de operação PLA-R.

VARIÁVEIS OPERACIONAIS	PLA-R
Temperatura [K]	473,15
Pressão [atm]	0,5
Volume [L]	1300
Fases	Líquida
CAT-1 [kg/hr]	0,1

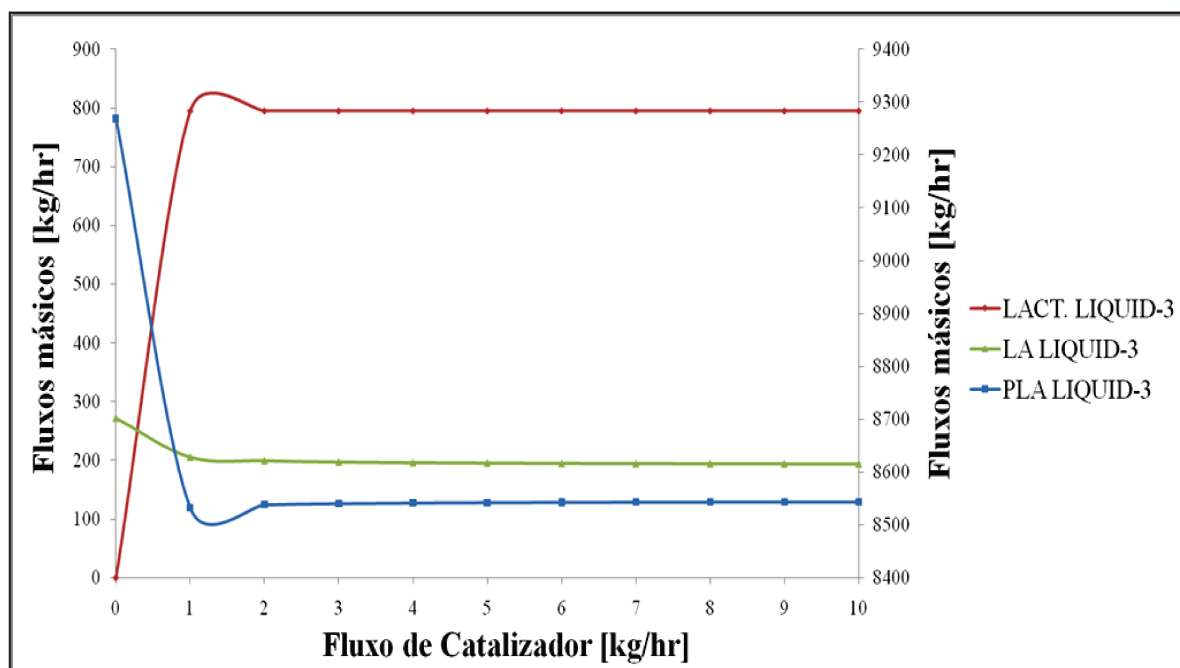
As Figuras A.8, A.9, e A.10 apresentam os perfis de fluxo mássico dos componentes no reator CSTR de polimerização do capítulo 5 (PLA-R).



Figura A. 8. Fluxos mássicos variando a temperatura do PLA-R.



Figura A. 9. Fluxos mássicos variando a pressão do PLA-R.

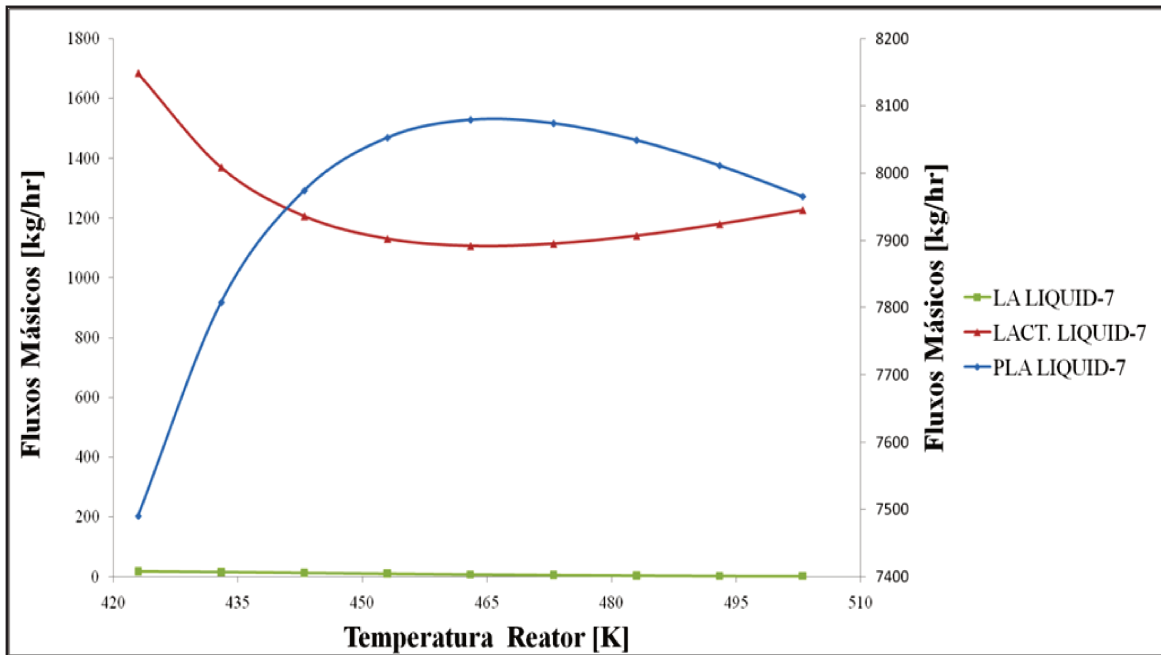

Figura A. 10. Fluxos mássicos variando o volume do PLA-R.

As Figuras A. 11 e A. 12 apresentam um estudo das variáveis, número de massa molar (MWN) e o número de grau de polimerização (DPN), desenvolvido variando a razão do ácido láctico e o lactídeo na entrada do último reator (PLA-R) e o fluxo de catalisador.

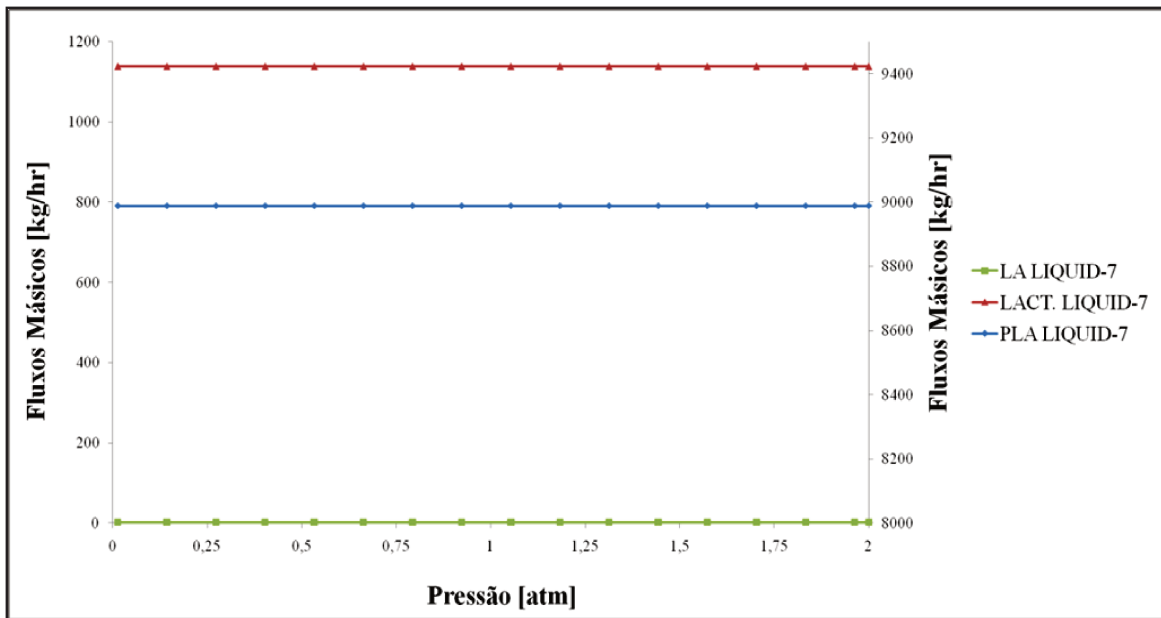

Figura A. 11. Número de massa molar variando o catalisador e a razão (AL/Lactídeo) do PLA-R.

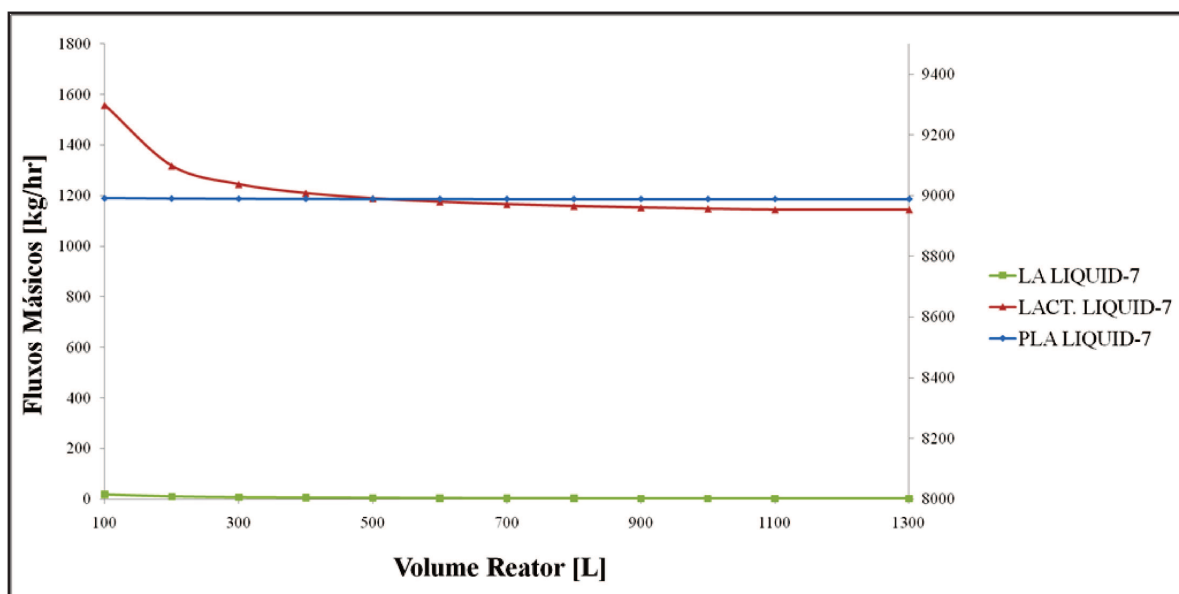
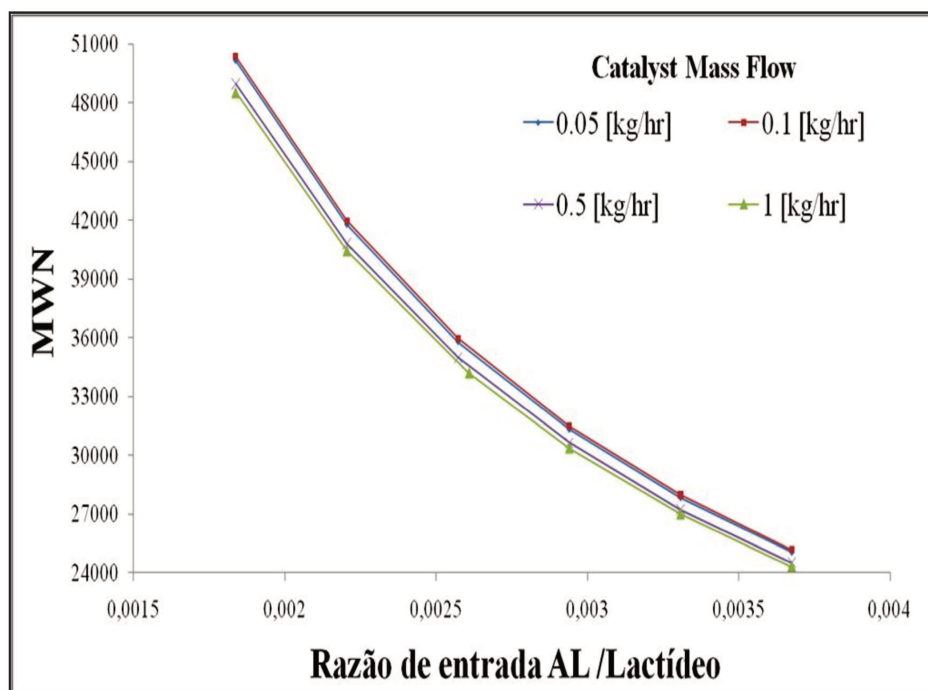
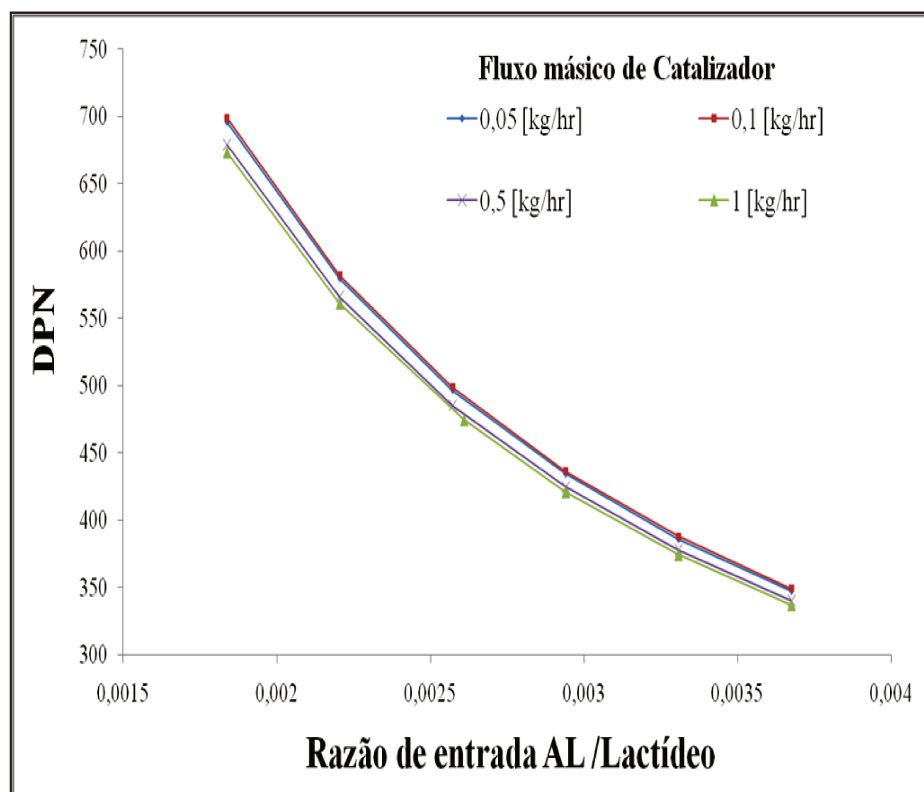

Figura A. 12. Número de grau de polimerização variando o catalizador e a razão (AL/Lactídeo) do PLA-R.